

# **CSI REPORT**

**NO. 14**

## **Sixty Years of Reorganizing for Combat: A Historical Trend Analysis**



**COMBAT  
STUDIES  
INSTITUTE**

CSI Reports are short-term research papers prepared in response to official inquiries. They are based mainly on secondary sources and provide basic information on the subject under consideration. The views expressed in a CSI Report are those of the author and not necessarily those of the Department of the Army or the Department of Defense.

## Combat Studies Institute

### *Missions*

The Combat Studies Institute was established on 18 June 1979 as a department-level activity within the U.S. Army Command and General Staff College, Fort Leavenworth, Kansas. CSI has the following missions:

1. Conduct research on historical topics pertinent to the doctrinal concerns of the Army and publish the results in a variety of formats for the Active Army and Reserve Components.
2. Prepare and present instruction in military history at USACGSC and assist other USACGSC departments in integrating military history into their instruction.
3. Serve as the U.S. Army Training and Doctrine Command's executive agent for the development and coordination of an integrated, progressive program of military history instruction in the TRADOC service school system.

# **CSI REPORT**

**NO. 14**

## **Sixty Years of Reorganizing for Combat: A Historical Trend Analysis**

**Combat Studies Institute**

**U.S. Army Command and General Staff College**

**Fort Leavenworth, Kansas 66027-1352**

**December 1999**

**For additional copies of this CSI Report, download this booklet from the CSI website at:  
<http://www-cgsc.army.mil/csi/>**

## Contents

Figures	v
Introduction	1
Triangular Infantry Division, 1939	3
Armored Division, 1940–1943	9
Division Reorganization, 1947–1948	14
Pentomic Division, 1955–1963	19
ROAD (Reorganization Objective Army Divisions), 1960–1963	23
11th Air Assault Division (Test), 1963–1965	28
1st Cavalry Division (TRICAP), 1971–1974	33
Division Restructuring Study (DRS), 1975–1979	37
Division 86, 1978–1980	41
High Technology Test Bed (HTTB)/High Technology Light Division (HTLD)/ High Technology Motorized Division (HTMD) (9th Infantry Division), 1980–1988	45
7th Infantry Division (Light), 1983–1986	51
Force XXI/EXFOR/Experimental Division, 1993–1997	55



## Figures

1. Infantry Division, 15 July 1943	8
2. Armored Division, 15 September 1943	13
3. Infantry Division, 7 July 1948	18
4. Pentomic Infantry Division, 1 February 1960	22
5. ROAD Division Base, 1961	27
6. Howze Board—Air Assault Division, 1963	32
7. TRICAP Division	36
8. Division Restructuring Study (DRS) Division (1976)	40
9. Heavy Division, 1 October 1982	44
10. Motorized Division (HTMD), 1984	50
11. Light Division, 1 October 1985	54
12. Force XXI (1995)	60

## Introduction

Throughout the twentieth century, the U.S. Army has periodically reviewed the structure and organization of its primary combat unit, the division, to posture itself better to meet changing requirements. Since 1939, the Army has conducted at least eleven such reviews with associated testing and validation exercises, the most recent being the reorganization of the light and heavy divisions in the mid-to-late 1980s. Given the significant changes in the world political environment since the collapse of the Soviet Union and the Warsaw Pact in the early 1990s, another such review is warranted, if not overdue.

In November 1999, Gen. Eric Shinseki, the Army Chief of Staff, directed the U.S. Army Training and Doctrine Command to undertake just such a comprehensive review. In response, the TRADOC commander, Gen. John Abrams, began the development of a brigade-sized force capable of rapid deployment, yet with the staying power of the current heavy force. Toward that end, the Combined Arms Center tasked the Combat Studies Institute to analyze four U.S. Army division/brigade restructuring initiatives that took place between the years 1960 to 1994 in an attempt to “determine critical historical insights gained and common themes from previous Army experiments germane to standing up the Prototype [Initial] Brigade.”

To provide a broader historical context and a wider range of key themes and trends that may be relevant to the current restructuring efforts, the Combat Studies Institute expanded its efforts to include several additional restructuring initiatives that have occurred since 1939. Twelve significant reorganization efforts fall within this period: the Triangular Infantry Division, 1939; the Armored Division, 1940–43; the Division Reorganization of 1947–48; the Pentomic Division, 1955–63; the Reorganization Objective Army Division (ROAD), 1960–63; the 11th Air Assault Division (Test), 1963–65; the 1st Cavalry Division (TRICAP), 1971–74; High Technology Motorized Division, 1980–88; the 7th Infantry Division (Light), 1983–86; the Division Restructuring Study (DRS), 1975–79; Division 86, 1978–80; and Force XXI Experimental Force (EXFOR), 1993–97. The following analysis takes the form of a case study on each of these efforts. Each case study begins with an overview of the circumstances that generated the restructuring initiatives in question. The overview is followed by an analysis of the following focus areas: proposed unit missions; preparatory training; unit field test methods; testing results; TOE-required resources versus MTOE manning; equipment; technology issues; impact of conversion on unit readiness; operational/wartime validation; and other insights gained. The final chapter of this work draws upon the twelve case studies to illuminate significant common themes in the Army’s perennial efforts to improve its capabilities through reorganization.





# TRIANGULAR INFANTRY DIVISION, 1939

**BACKGROUND AND PROPOSED UNIT MISSIONS:** During the Spanish American War, the U.S. Army implemented *ad hoc* triangular divisional organizations with three brigades each of three regiments. Every regiment had three battalions of four companies. The Field Service Regulation of 1905 formalized this organization. However, a division was not again employed until 1913 when Secretary of War Henry Stimson assembled an experimental "Maneuver Division" on the Mexican border.

During World War I, Army planners quickly observed that trench warfare made tactical maneuver difficult. This new form of warfare emphasized firepower, exacting heavy casualties. The solution was to form a division large enough to absorb heavy losses and continue combat operations. Therefore, the Army provisionally organized into square divisions, with two brigades of two regiments each. The regiment, in turn, had three infantry battalions and a machine-gun company. These large divisions met the needs of trench warfare in relation to power, endurance, shock action, and easy passage through lines, but they were relatively difficult to maneuver and support. At the war's end, the Army retained its square infantry divisions as a type unit.

In 1920, General John J. Pershing, who had commanded the American Expeditionary Force in World War I, called for an elastic and mobile three-unit system built to operate in North America. Mobility was especially important, and although the square division was not suited to mobile warfare, a divisional-type organization henceforth became the pillar of U.S. mobilization. However, with no enemy in sight and the nation's adoption of an independent foreign policy, Congress did not provide the monies to support a relatively large army. In fact, military budgets shrank consistently until 1935.

Discussion over the shape of the new division finally began in 1929 as part of the modernization debate and continued for the next ten years. That year, the Assistant Chief of Staff, G-3, Major General Frank Parker, reported that European countries were creating the sort of armies that could lead to unprecedented combat velocity in war. For instance, Britain was experimenting with armor, France with motorization, and Germany, handicapped by treaty restrictions, was dreaming of things to come. All were discarding older, unwieldy division designs. Since the Army was planning to modernize its equipment by introducing semiautomatic rifles and light machine guns, General Parker suggested that parts of the 2d Infantry Division conduct tests to discover the optimum combination for these weapons. The Chief of Staff, General Charles E. Summerall, agreed to the proposal and extended it to the entire division. The test was conducted by the Infantry Board. Several proposals emerged for a triangular division, but the matter lay dormant after 1931 because of the budget cuts brought about by the Great Depression (see figure 1, page 8).

In 1935, General Malin Craig, the new Army Chief of Staff, ordered a complete review of organization and tactics, and in 1936, he created the Modernization Board to examine the

Army's organization. When assembled, the board concluded that trying to reorganize the entire Army in the course of a single study was too complex and impractical a task. Instead, it chose to concentrate its energies on redesigning the infantry division. Part of its rationale was that the structure of higher commands rested on the infantry division's design. Drawing upon expertise from the Army school system, the General Staff, and earlier studies of foreign armies, it endorsed a triangular infantry division design. The board finally delivered its report to General Craig in 1936. After reviewing it, he decided to test the design in 1937.

In the new formulation, the brigade headquarters and one of the infantry regiments of the square division disappeared. While the old square division consisted of twenty seven battalions made up of 108 company-size formations, the new organization had two field artillery regiments, three regiments of infantry with three infantry battalions each, and was supported by division engineer, signal, ordnance, quartermaster, medical, and military police units, with a fire support element at each echelon. The new formation consisted of twelve battalions with sixty company-size elements.

Several considerations influenced the new organization's design. One of the most important was the need for improved mobility and increased flexibility. The triangular division enhanced mobility because it used less road space and could deploy from movement formation faster than the square division. It was more flexible because it eliminated an excessive reserve. The three-regiment arrangement, moreover, provided a convenient reserve for the division commander. In addition, smaller unit size allowed the use of a separate division as a reserve. Eliminating the brigade-level command allowed for faster transmission of orders. Another important issue was the need to exploit new technology, weapons, and firepower. General Craig specifically directed the War Department staff to examine reorganization and tactical changes that optimized motorization, mechanization, and increased firepower. Finally, planners designed the division assuming that North America would be the probable theater of operations.

**PREPARATORY UNIT TRAINING:** The proposed infantry division design was tested by elements of the 2d Infantry Division in 1937; other units were drawn from the Army as a whole. In general, equipment was allocated for the test from the rest of the Army. The design was refined and tested again by the same division in 1939.

**UNIT FIELD TESTS:** The field test, the first of its kind, was held in Texas between September and November 1937. The Provisional Infantry Division (PID) was composed of troops from the entire Army; the largest portion came from the 2d Infantry Division. It tested a smaller (than the square division) triangular division design which incorporated attached antitank and antiaircraft battalions and an observation squadron. The revised division design was tested in February–August 1939. The 2d Infantry Division was again used as the test unit in Texas. Designated the Provisional 2d Division, its commander, Major General Walter Krueger, conducted the tests. The test director, the VIII Corps area commander, Major General Herbert J. Brees, concurred with some of the commander's

recommendations but disagreed with others. The main area of contention was the full extent of motorization the two men saw as optimal.

**TESTING RESULTS:** The report of the 1937 test results was written by a special committee consisting of Major General Fox Connor, then-Colonel George C. Marshall, and Brigadier General Lesley J. McNair (the PID Chief of Staff). Although Marshall feared that the committee would appear to be stacked in favor of the smaller division design, its report, largely written by McNair, identified the same weaknesses critics had discovered. Instead of assigning the division to a fixed corps as the critics wanted, the committee recommended a smaller, more powerful division, emphasizing increased firepower, range, and mobility. After examining the report, the Modernization Board redesigned the division, using the triangular concept, with three combat teams built around three regiments. In 1938, General Craig decided to spend most of 1939 evaluating it before determining its fate.

In September 1939, the Modernization Board recommended a new infantry division design to Marshall (who as a full general had recently been appointed Army Chief of Staff). The board recommended placing general officers in charge of its infantry and artillery components, a motorized engineer battalion, and an increased number of trucks for the quartermaster. The division would be completely motorized. By late 1940, the design had been modified. The artillery regiments were eliminated and replaced by divisional artillery, consisting of three battalions of 105-mm cannon and one 75-mm and 155-mm battalion. A reconnaissance troop was also added.

**TOE REQUIRED RESOURCES VERSUS MTOE MANNING AND EQUIPMENT:** When the designs were first tested, no change in total Army strength was expected. The division had two authorized strengths, a peacetime one of 7,970 officers and men and a wartime strength of 11,485. After peacetime conscription was instituted in 1940, the Army would get its required manpower. However, there were equipment shortages as well as inadequate housing and training facilities for the troops. In one year, the Army expanded from five understrength divisions to twenty-two divisions. Simultaneously, American industry was supplying the U.S. military as well as Great Britain.

Since planners assumed the division would be part of a larger force providing combat and logistical support, the new infantry division was “streamlined”; it had a reduced number of organic artillery and auxiliary units and no organic armor. After the tests, the division size was revised upward to 15,514 officers and men. World War II infantry division size adjustments decreased its size to 14,253 officers and men because of shipping and manpower shortages. Lesley McNair, by now a lieutenant general and Chief of Army Ground Forces, expended special efforts to ensure that, with a minimum of specifically defensive weapons, the division remained a compact offensive unit streamlined for open warfare and reinforced by “pooling” common support units at corps and army level.

**TECHNOLOGY ISSUES:** All the technology issues were concerned with

modernization. The Army was grappling with issues raised by mechanization, aviation, electronics, new weapons, and the tactics to best use new tools, like voice radios, close air support, self-propelled artillery, tanks, semiautomatic rifles, and light machine guns. The Army tested a new division that was made more practicable by reliable motorized transport; light, reliable voice radios; and new infantry weapons that increased the individual soldier's firepower.

**DETRIMENTAL EFFECT UPON UNIT READINESS DURING CONVERSION:** During the interwar period, the Army's divisions gradually declined as fighting organizations. Budgetary constraints that began in the 1920s effectively destroyed the possibility of training units as combined arms teams. Constraints included reductions in the Regular Army's size and an increase in the size of the Air Corps, at the expense of Army troop strength. Units were inactivated, and the onset of the Great Depression led to some further budgetary cuts.

General Marshall approved the triangular division reorganization in mid-September 1939, after the start of war in Europe. He began by ordering the reorganization of the 1st, 2d and 3d Infantry Divisions and the activation of the 5th and 6th Infantry Divisions. Given the state of the Army at the time, no real loss to preparedness was experienced during the change. The nation was not at war yet and, therefore, not tested during the conversion period.

Throughout the interwar period, the Army did not have the money to man, equip, and test divisions. Instead, the planners concentrated on designing a division organization and developing new concepts for its employment. Assuming the division would be needed to repel an invader, the planners worked out an appropriate span of control, the number of staff echelons, the mix of infantry and artillery, reconnaissance, the role of engineers, and organizing of combat service and support. The triangular division appeared to offer the best solution to General Marshall's problems because National Guard divisions could easily adopt it, even though they remained "square" until 1942. Losing a regiment was a thorny political issue for the National Guard. In 1940, another seventeen divisions were either activated or inducted into Federal service.

**OPERATIONAL/WARTIME VALIDATION:** Divisional organization rapidly adjusted to the demands of World War II. Initially, three factors influenced division organization: availability of men, shipping space, and the quality of weapons. The latter proved most influential, forcing the Army to make structural changes for new weapons systems or eliminating failed weapons systems. During World War II, three other experimental division types were formed, the light, the alpine, and the motorized divisions. Their wartime experience confirmed General McNair's suspicions about excessive specialization. The standard, triangular infantry division was suitable in all of the environments in which the Army fought. However, in striving for mobility, General McNair "streamlined" the division too much. As World War II ended, the Army attempted to give infantry divisions back some of the resources they needed, but this effort came too late to

provide much benefit.

**INSIGHTS GAINED:** The triangular division continued without substantial change from the end of World War II until 1955. After the war, the Army analyzed the strategy, tactics, and administration of theater forces. This analysis revealed that “streamlining” had indeed gone too far. Therefore, the Army implemented several recommended changes to the infantry division design in 1948–50. The main alteration was to increase firepower and make organic to the division such units as armor, previously assigned from higher headquarters during combat.

The 1949 reorganization raised authorized infantry division strength to 18,804 men. A tank battalion was made organic to the division, and each infantry regiment received an organic tank company. Antiaircraft artillery, strengthened engineer, military police, maintenance and quartermaster units, as well as men to provide communications, intelligence, reconnaissance and administration were also added.

The Army made these adjustments based on combat experience while attempting to adjust to the increased difficulty of conducting reconnaissance and gathering intelligence on a deeper and wider battlefield. Initially, the Army assumed the atomic bomb would not substantially alter the nature of ground combat.

# Infantry Division, 15 July 1943

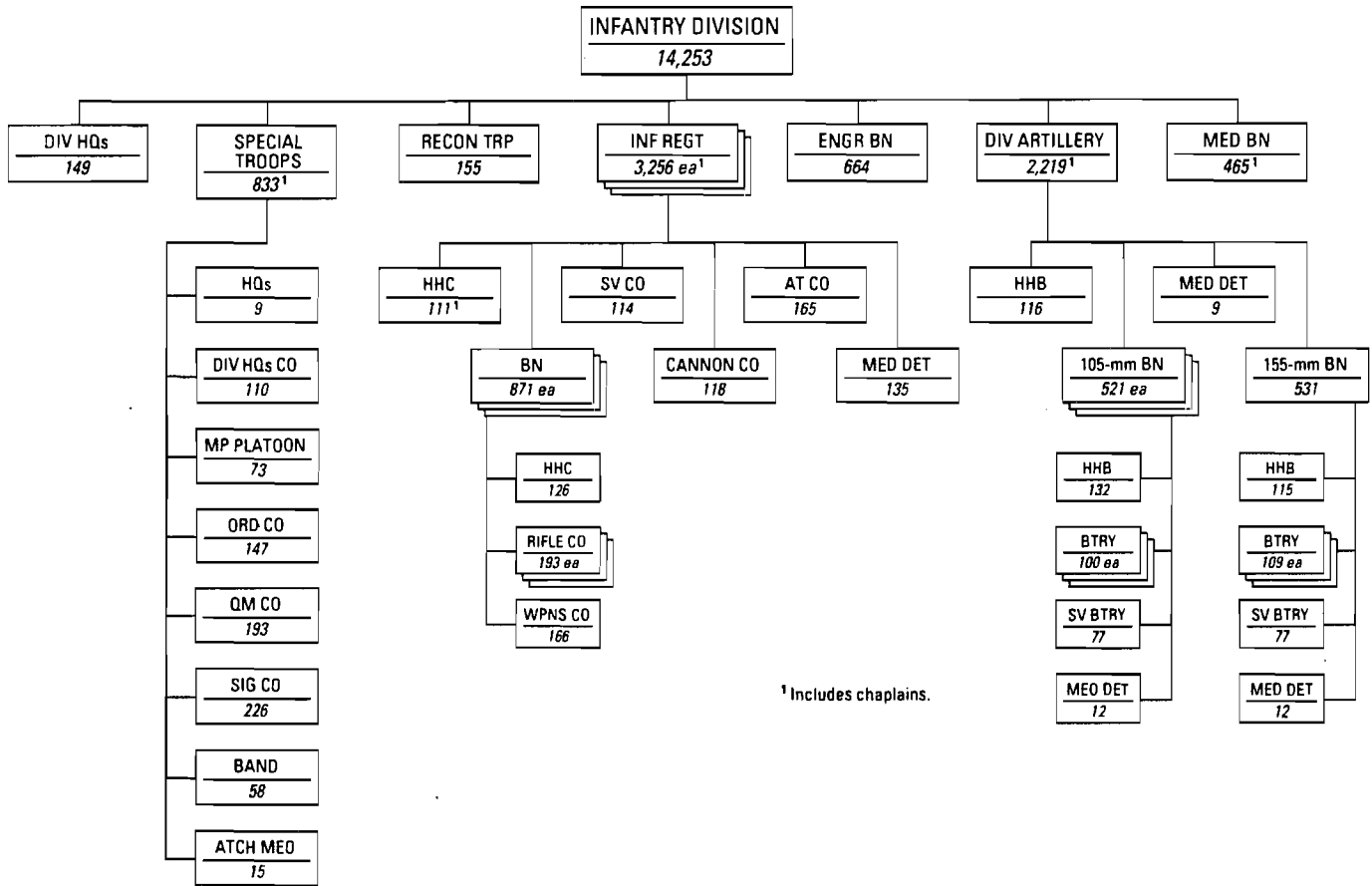

<sup>1</sup>Includes chaplains.

**FIGURE 1**

## ARMORED DIVISION, 1940–1943

**PROPOSED UNIT MISSION:** The tank first emerged as a weapon of war in World War I, where it functioned almost exclusively in the infantry-support role. However, even during that conflict, armor advocates began to suggest that tanks, operating in mass, would someday constitute the arm of decision. A series of experiments conducted by various nations between the world wars suggested that large armored forces were indeed viable. American observers (including the Secretary of War) were particularly aware of the British Army's tests conducted on Salisbury Plain (1927–37) in which mechanized forces organized in brigade and division strength conducted a variety of combat missions.

American initiatives during this period included brigade-level tests conducted at Camp Meade, Fort Eustis, and Fort Knox. Although the Infantry branch claimed proponency for tanks, the initiative for mechanized experimentation shifted toward Cavalry by the late 1930s, culminating in the creation of the 7th Cavalry Brigade (Mechanized) by 1938. Ironically, the incumbent Chief of Cavalry was a dedicated horseman who placed little value on his own branch's experimental efforts. Not until May 1940 did the Cavalry's mechanized brigade join up with a brigade of the Infantry's tanks to form a provisional division for testing in maneuvers.

The German conquest of France in the spring of 1940 triggered the creation of an American armored arm. In July of that year, the Chief of Staff of the Army, General George C. Marshall, directed the creation of an Armored Force, which was to be independent of the other combat arms. Initially, the Armored Force consisted of I Armored Corps and the 1st and 2d Armored Divisions, which were created out of the existing Infantry and Cavalry tank and mechanized formations. In keeping with Cavalry's recent dominance of the mechanization program, the mission of the new armored division was mobility oriented. Envelopment, exploitation, and other high-maneuver functions constituted the armored division's perceived battlefield missions.

As constituted in 1940, the armored division reflected its Cavalry parentage. The main fighting element was an armored brigade containing two regiments of light tanks (for a total of six battalions), one regiment of medium tanks (two battalions), and a regiment of artillery (two battalions). An infantry regiment of two battalions, an artillery battalion, a reconnaissance battalion plus engineers and other support troops occupied a strictly secondary place within the division structure. The division's wartime TOE strength was 11,200.

**PREPARATORY TRAINING:** The 1st Armored Division assembled at Fort Knox, and the 2d Armored Division came together at Fort Benning. Lacking any branch-specific training materials, the new armored formations borrowed and modified training programs from the older combat arms until Armored Force headquarters could generate programs of instruction. The new formations spent the fall and winter of 1940–41 in individual and small-unit training. The spring of 1941 was dedicated to regiment, brigade, and division-level training. The 2d



Armored Division also conducted a series of tests in conjunction with ground-attack aviation. All training programs aimed toward preparing the armored divisions for corps- and army-level training to be conducted later that year.

**UNIT FIELD TESTS:** The U.S. Army conducted a series of maneuvers in the summer and fall of 1941 that were intended to both train and test. The armored divisions fared very well in the corps-versus-corps maneuvers conducted during the summer. Utilizing their high mobility, armored formations repeatedly out-maneuvered their infantry-heavy opponents and won impressive “victories.” During the autumn army-versus-army maneuvers conducted in Louisiana and the Carolinas, the armored divisions encountered antitank elements that decimated the attacking armored formations. Thus, it was revealed that the armored division was over-reliant on light tanks and lacked both the assets and the command structure to conduct combined-arms combat.

**TESTING RESULTS:** The Armored Force quickly took to heart the lessons of the maneuvers. In 1942, a new division organization was approved. The new division structure included two rather than three armored regimental headquarters, while the infantry regiment was increased to three battalions. The three artillery battalions were consolidated under a division artillery headquarters. The brigade headquarters was eliminated, as were certain other elements. For tactical control of combat elements, the new division structure included two brigade-level “combat command” headquarters, to which any mix of combat and support elements could be assigned for specific missions. Signifying a shift in emphasis from mobility toward fighting power, the new division contained four battalions of medium tanks and only two battalions of light tanks. Total TOE strength was 14,618, with much of the increase accounted for by additional combat service support assets.

**TOE REQUIRED RESOURCES VERSUS MTOE MANNING AND EQUIPMENT:** At the time of activation, the 1940 armored division had a TOE peacetime strength of 9,500 and a wartime establishment of 11,200. The Armored Force as a whole received only 9,500 when established. However, two months after the first two armored divisions were activated, Congress passed a peacetime Selective Service act which effectively solved the Army’s manpower shortages.

Shortfalls in weapons and equipment were less readily solved. In place of the 3,243 vehicles that each armored division required, the Armored Force initially acquired a total of less than 1,000. Of the 287 light and 120 medium tanks required for each division, a total of 400 light and only 18 medium tanks were on hand. By the summer of 1941, most equipment requirements had been met but often with expedient or improvised equipment. The armored divisions went through the 1941 maneuvers with “medium” tanks that were actually light tanks marked with a large “M.” Self-propelled artillery not being available, the armored artillery battalions relied upon truck-drawn field pieces well into 1942.

When a medium tank did become available in large numbers, it was the M-3 model which

was itself an improvisation. Not until 1943 did the M-4 Sherman tank displace the last of the M-3s.

**TECHNOLOGY ISSUES:** The armored division was a response to technology in the form of the tank, but the tank did not “drive” the creation of the armored division. The tank was more than twenty years old when the 1940 armored division was crafted and had long occupied a comfortable spot in doctrine as an infantry-support weapon. The key developments precipitating the emergence of the armored division were conceptual, not technological. However, it is true that a host of supporting technology had to emerge before armored formations could live up to their potential. Reliable motor transport, self-propelled artillery, portable radios, and light liaison aircraft were just a few of the technologies that made the armored division effective.

**EFFECT UPON UNIT READINESS DURING CONVERSION:** The 1st and 2d Armored Divisions were both new formations and were not conversions of existing divisions. Within a year of their activation, these two armored divisions were rated as being among the Army’s most combat-ready. This observation should be taken in context. The entire Army was in the throes of expansion, and virtually every division underwent major upheavals in personnel and/or organization. Thus, the 1st and 2d Armored Divisions were actually the least-unready formations in a turbulent period.

**VALIDATION IN BATTLE:** The 1942 version of the armored division first saw battle in Tunisia and suffered a notable defeat in the 1943 battle of Kasserine Pass. Few if any observers blamed the division structure for that debacle. A further reorganization in 1943 resulted in a leaner, more flexible, division, but this reorganization was driven mainly by an Army-wide requirement to economize on manpower. It does not appear to have been a direct result of combat experience. The 1943 armored division did away with all regimental headquarters (see figure 2, page 13). The division included three battalions of tanks, three of infantry, and three of artillery. The two combat commands of the 1942 structure were increased to three. Total manpower decreased from 14,618 to 10,937, with much of the savings coming from the elimination of headquarters and logistics organizations. Of the sixteen armored divisions fielded in World War II, fourteen adopted the lean 1943 structure. Two served throughout the war in a modified version of the heavier 1942 TOE. Both variants were successful in combat, though both frequently required augmentation in infantry and artillery. The versatile “combat command” concept has persisted to the present day.

**INSIGHTS GAINED:** The process of creating and then modifying an American armored division was not undertaken in a vacuum. With war already raging in Europe, the U.S. Army had a wealth of combat data upon which to draw in formulating its own doctrines and force structures. Elements of both British and German armored doctrine can be perceived in the evolution of the U.S. armored force.

Though the 1941 maneuvers were the most important “in-house” trials undertaken, they were not the ideal testing venue for the new divisions. Aside from testing the armored divisions, the maneuvers were also intended to serve as capstone unit training exercises, as a “college” for higher commanders who had not seen corps or army-size formations since 1918, and as doctrinal tests for other forces, such as airborne and antitank. In short, there were too many variables in play. The Armored Force was fortunate that it was able to discern the appropriate lessons from these multifaceted exercises

Armored Division, 15 September 1943

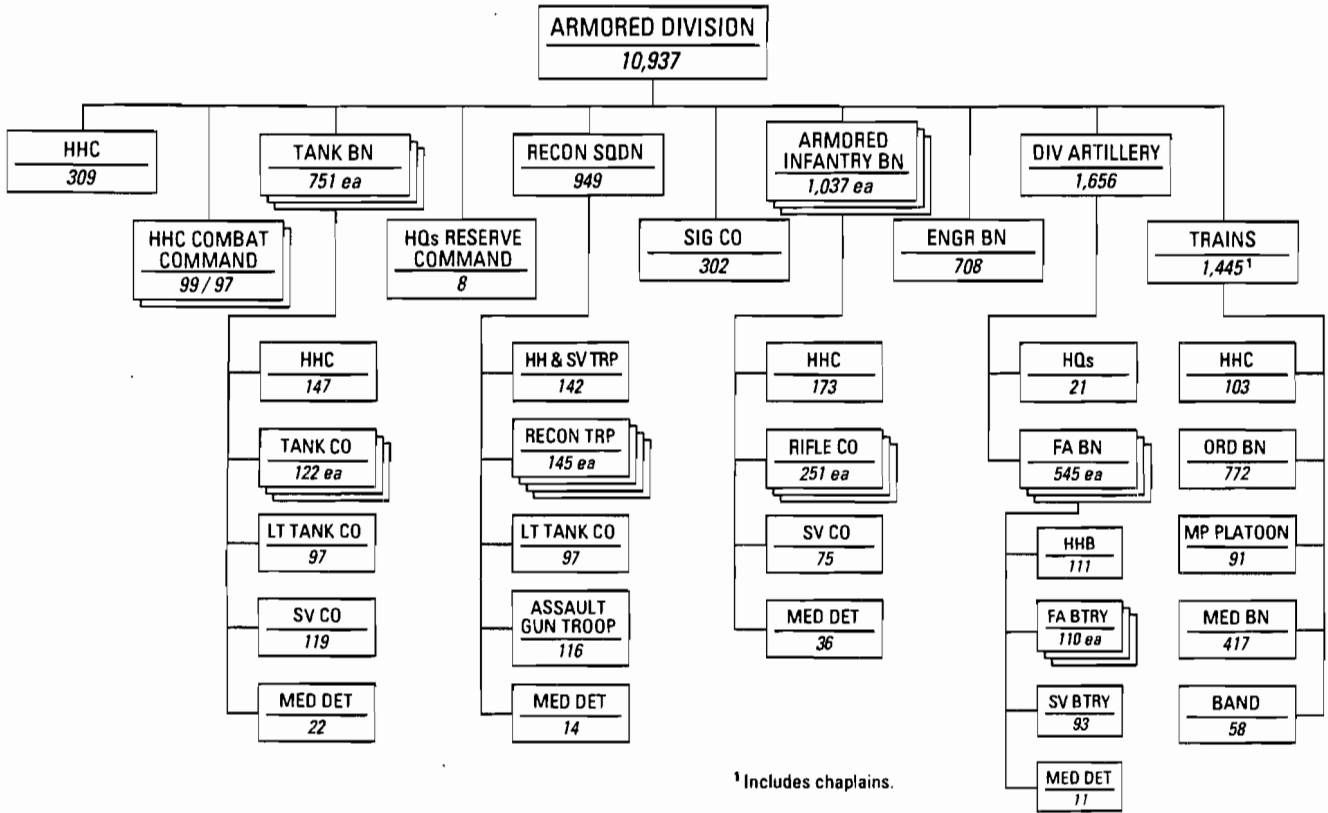

FIGURE 2

## DIVISION REORGANIZATION, 1947–1948

**BACKGROUND AND PROPOSED UNIT MISSIONS:** After World War II concluded in Europe, the U.S. European Theater of Operations formed the General Board, consisting of many committees, to analyze strategy, tactics, and administration of theater forces. One committee was assigned the task of examining the need for various types of divisions. It recommended the Army retain only three division types—infantry, armored, and airborne—concluding that the standard infantry division could accomplish various diverse missions, making special divisions (light or mountain) unnecessary.

The General Board defined the division as the basis of Army organization. Wartime experience showed the infantry division's subordinate units deficient in strength and composition to ensure their ability to conduct independent offensive and defensive operations with maximum efficiency. The absence of tanks in the infantry division's organization was especially onerous.

The infantry division committee proposed to increase regimental size, adding soldiers to provide communications, intelligence, reconnaissance, and administration, as well as improved weapons for cannon and antitank companies. To ensure adequate intelligence and security, the committee recommended increasing the divisional cavalry troop to a full squadron. In addition, the committee called for more artillery and organic armor. This initial proposal increased the size of an infantry division to 20,578 officers and men.

Using the 1943 armored division as a base, the armored division committee added a fourth 105-mm howitzer battalion and an antiaircraft artillery battalion. The committee members further believed that the combat command organization was weak because it did not have any units assigned to it. It recommended, therefore, that three regiments replace the combat commands, each regiment consisting of one tank and two armored rifle battalions. This increased the strength of the armored division to 19,377 officers and men, doubling the size of the 1943 armored division.

The Army Staff received these reports and passed them on to the Chief, Army Ground Forces, General Jacob Devers, late in 1945. Devers refrained from taking any action until infantry and armored conferences sent their recommendations to him after their meetings the next spring. In July 1946, he forwarded proposals for new infantry and armored divisions to the General Staff. These proposals combined the recommendations of the General Board and the infantry and armored conferences. The new infantry division was similar to those created late in the war, when manpower caps were lifted. The armored division kept its 1943 configuration but was augmented to correct organizational deficiencies discovered during the war. Except for the atomic bomb, these new divisions reflected the Army's war experience and its belief that the nature of ground combat had remained unchanged.

General Dwight D. Eisenhower, the Army Chief of Staff, sent these divisional proposals to senior officers and the Chief of Staff's Advisory Group. Eisenhower himself thought the units were too big and that they tried to account for every contingency under every condition, violating the wartime principles of flexibility and economy of force. In contrast, however, his two groups of senior officers believed the division did not have too many people or too much equipment; the proposal augmented the divisions only by those units that had been habitually associated with them in combat. As finally agreed upon, the new infantry division organization retained much of the structure of the World War II division. It added two guns to every artillery battery, provided an organic antiaircraft artillery battalion and a tank battalion to the division, and furnished one tank company to each of the three infantry regiments (see figure 3, page 18).

**PREPARATORY UNIT TRAINING:** The new units were not radical departures from the older divisional organizations, so there were no problems converting units. The problem lay with Army training in general.

Training programs in the late 1940s did not receive proper funding because the Army felt no sense of urgency about the evolving world situation. Because much of the Army was on occupation duty, training for war was further neglected. Until 1949, basic training lasted only eight weeks, and graduates usually had to receive much more training when they arrived at their assigned units. Part of the training problem lay in Army procurement policy. While the Army bought food, clothing, and medical supplies, it was not able to buy ammunition or develop new weapons systems, and it had to rely on obsolete or obsolescent equipment. Shortages of men and supplies combined with inadequate training led to low combat readiness.

**UNIT FIELD TESTS:** Because it was not a radical departure from previous designs, the new design did not require field testing.

**TESTING RESULTS:** Again, the relatively minor organizational changes were not deemed to require testing.

**TOE REQUIRED RESOURCES VERSUS TOE MANNING AND EQUIPMENT:** In 1948, the new division designs were codified. New tables of organization and equipment published by the Department of the Army authorized infantry divisions of 18,804 officers and men. Each new infantry division consisted of three infantry regiments with three battalions, altogether nine infantry battalions. Each regiment included an organic tank company, and the division had an independent tank battalion as well as an antiaircraft artillery battalion. Artillery batteries were increased from four guns to six. Armored divisions would consist of 15,973 officers and men. The armored division retained its 1943 command structure of combat commands, with three medium tank battalions, three armored infantry battalions, and three 105-mm howitzer battalions. However, the reserve command was made identical to the two existing combat commands, the tank destroyer

battalion was replaced by a heavy tank battalion, and an antiaircraft artillery battalion and a replacement company were added.

The new organizational structure was to be implemented in 1948–49. Of the Army's ten divisions, only one (the 1st Infantry Division in Germany) attained its full table of organization strength before 1950. Because of serious shortfalls in equipment, manpower, and funding, the strengths of the other nine divisions varied between 55 and 80 percent. Each of their infantry regiments lacked one battalion and the tank company, while the artillery battalions had only two firing batteries instead of three. Only one company or battery was filled in the separate tank and antiaircraft artillery battalions. The actual strengths of the divisions ranged between 12,500 and 13,650 officers and men. The Army was, for all practical intents and purposes, hollow.

The skeletonizing of the divisions handicapped a doctrinal system that was designed to function tactically with three-battalion regiments. In practical terms, a regimental commander in combat could only use a single battalion in the line if he wished to maintain a reserve, or he could place both battalions in the line and operate without a reserve. This violated the Army's tactical doctrine of keeping a reserve to finish off an enemy or repulse a counterattack. Removing the organic armor from the division also negated one of the primary purposes of the reorganization.

**TECHNOLOGY ISSUES:** There were no technology issues *per se*. The new design incorporated incremental improvements to weapons and equipment, especially the new medium tank and more tracked vehicles, without difficulty.

**DETRIMENTAL EFFECT UPON UNIT READINESS DURING CONVERSION:** Conversion produced only a small effect on unit readiness, an effect which paled before the Army's larger manpower, training, and fiscal problems. In 1946, the Army fielded seventeen divisions, had a strength of 1,891,011 officers and men, and a budget of \$189.6 billion. In 1950 it fielded ten divisions, was 593,167 strong, and was budgeted at \$43.2 billion. Approximately 38 percent of the force was assigned overseas, mostly performing occupation duty in Europe and Japan.

**OPERATIONAL/WARTIME VALIDATION:** Although all Army units were understrength and suffered from training deficiencies, the units in Japan were the first to suffer the consequences of budget and manning deficiencies when they were committed to the Korean peninsula to turn back the North Korean invasion in the summer of 1950.

The first unit to deploy to Korea was Task Force Smith, which consisted of elements of the 24th Infantry Division. The remainder of the division arrived soon after, followed by the 25th Infantry Division and the 1st Cavalry Division. To bring these units closer to their wartime strength, the remaining division in Japan, the 7th Infantry Division, was stripped of troops. In the first two weeks of the war, the 24th Infantry Division was the only major

American combat unit in Korea. Operating with its skeletonized structure, this division suffered a series of defeats before finally rallying with other American and South Korean forces in the Pusan Perimeter. The causes of this debacle could be traced directly to prewar policy and preparation. Once the nation fully manned and equipped its divisions in Korea to the 1948 standard, the divisional design proved more than adequate for the requirements of the war.

**INSIGHTS GAINED:** Army doctrine in Field Manual 100-5, *Field Service Regulations, Operations*, published in 1949, distilled what the Army had learned in worldwide combat between 1941 and 1945, as did the 1948 divisional reorganization. Both were based on the triangular division design that had been developed before and modified during World War II. The new divisional structures applied the insights expensively obtained through wartime experience to enhance divisional firepower significantly. However, this new ideal was unattainable in the postwar political and social climate in the United States. The national mood of complacency, budget cuts, and recruitment shortfalls meant the new division organizations could not be fully manned. The lessons of history had been applied in theory, but political realities precluded their implementation in practice. The disaster of 1950 was the unfortunate result.



# Infantry Division, 7 July 1948

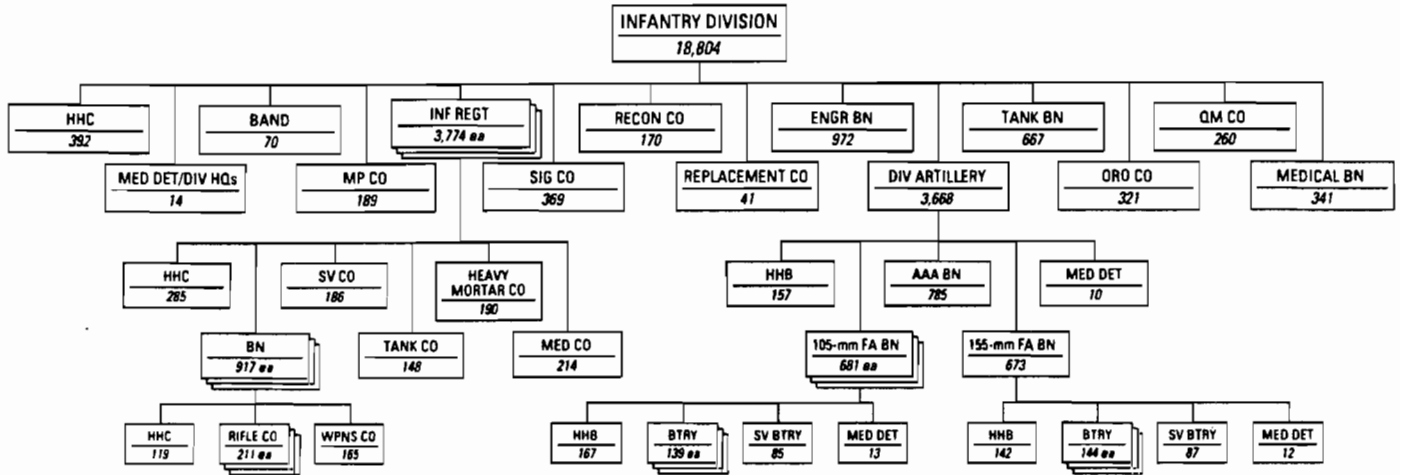

**FIGURE 3**

## PENTOMIC DIVISION, 1955–1963

**BACKGROUND AND PROPOSED UNIT MISSION:** In 1954, no U.S. Army officer would have claimed that the institution had been prepared to conduct ground warfare in Korea. To the extent that the United States had a coherent defense policy after World War II, it was to rely on strategic nuclear weapons to deter the sort of conventional military aggression that had precipitated World Wars I and II. The U.S. Army's mission under this scenario, prevalent until mid-1950, was to guard the bases and occupy the countries from which strategic nuclear weapons would be launched. Presumably, this would enhance the credibility of the nuclear deterrence that would prevent new wars.

The Korean War discredited these essential assumptions. In June 1950, the United States committed its army to defeat a conventional invasion, and it did so in a place where it had never planned to fight, the mainland of Asia. Developments subsequent to the North Korean aggression suggested that ground forces in the next war might have to fight on a nuclear battlefield. Since the Soviet Union had conducted a controlled nuclear explosion in 1949, it would likely have deliverable nuclear weapons by 1954. Thus, the United States government and public opinion, exasperated by the military stalemate from 1951 to 1953, might insist on using tactical nuclear weapons in the future, rather than bear the burden of another long, protracted war.

The Pentomic Division was supposed to provide survivability and sustainability on a nuclear battlefield by increasing the maneuverability of the basic (subdivision) warfighting units (see figure 4, page 22). The army structured this division for a cellular battlefield of greater depth and dispersion, the older linear battlefield now being judged far too vulnerable in the nuclear age. To accomplish this new organization, army planners restructured the old "triangular" division in place since World War II. This division placed three regular platoons plus a heavy weapons platoon in each company and three regular companies plus a heavy weapons company (three maneuver elements and one firepower element) in each battalion. Building on these essential blocs, three battalions made up a regiment, and three regiments made up a division. The "Pentomic Division," as outlined by Army Chief of Staff Maxwell D. Taylor in October 1956, would have five relatively self-contained battle groups, each one made up of five companies. Being smaller than a regiment but larger than a battalion, a battle group was supposed to be both agile and strong, the combination necessary to enhance survivability in the face of nuclear explosions. The total strength of a division would be reduced from 17,700 soldiers in the typical infantry division (1947) to 14,000 in the pentomic force structure. According to division planners, so-called "fox hole strength" would not be degraded because reductions would come from staffs and combat service support.

**PREPARATORY TRAINING:** In Germany, Major General James Gavin, Commander, VII Corps, ran tactical exercises in 1954 testing the concept. The exercises confirmed the hypothesis that conventional infantry divisions were not ready for a nuclear battlefield. Gavin concluded that the army must adopt relatively independent battle groups, "each one capable of sustained combat on its own."

**UNIT FIELD TESTS:** In 1954, the 1st Armored Division at Fort Hood and the 47th Infantry Division at Fort Benning also conducted tests. In 1955, at operation Desert Rock VI (Yucca Flats, Nevada), the Army placed a composite armored force 3,000 meters from a thirty-kiloton nuclear explosion.

**TEST RESULTS:** Improved communications capabilities tested at Fort Hood and Benning seemed to suggest that the division commander would be able to control five, rather than just the three, units he had once commanded in the field. At Yucca Flats, when neither vehicles nor soldiers were disabled and where the latter were able to open up weapons fire within thirty seconds after the blast, the army felt it had preliminary proof that a pentomic battle group could survive on a nuclear battlefield.

**TOE REQUIRED RESOURCES VERSUS MTOE MANNING AND EQUIPMENT:** Initial plans for the Pentomic Division called for five direct-support (107-mm) mortar batteries for each battle group. When this was found to provide inadequate fire support, subsequent revisions called for support from five artillery battalions, one 105-mm and one 155-mm battery. Actual manning varied according to division, but the Army as a whole could not field as much artillery support as planned. Plans also called for enhanced airlift to deal with unforeseen emergencies such as Korea; the smaller size of a battle group (vis-à-vis a regiment) was supposed to be conducive to strategic mobility. The Eisenhower administration, however, emphasized nuclear deterrence, not flexibility, and therefore was not willing to build airlift at the expense of the Strategic Air Command.

**TECHNOLOGY ISSUES:** A major problem in technology was that, all plans to the contrary, contemporary communications equipment could not offset the size reductions in staffs and combat service support personnel. Nor could this equipment enable commanders to handle effectively their enlarged span of control. Division commanders found themselves swamped by communications with and activities related to sixteen different subordinate units. At the battle group level, now that battalions ceased to exist, a colonel and his staff had to coordinate five rifle companies, a mortar battery, a tank company, direct-support artillery, and a reconnaissance platoon.

**IMPACT ON UNIT READINESS:** “Every time I think of the . . . Pentomic Division I shudder,” said General Paul Freeman, former commander of Continental Army Command; “Thank God we never had to go to war with it.” The Pentomic Division simply did not have the capacity and capabilities to perform the basic warfighting functions necessary in combat: that is firepower and communication. Moreover, even if the Pentomic Division had been able to discharge its primary function, that is, fighting on the tactical nuclear battlefield, it would not have been able to function on the lower ends of the spectrum of conflict, primarily against insurgencies.

**OPERATIONAL/WARTIME VALIDATION:** The division design was never made operational or tested in combat.

**INSIGHTS GAINED:** As Colonel Henry E. Kelly wrote in *Military Review*, “reliance upon words [i.e., concepts and doctrine] which are not backed by practical ability is extremely dangerous.” Whatever theoretical merits the Pentomic Division had, those merits remained theoretical because the United States, in general, and the Eisenhower administration, in particular, would not develop and fund the artillery, communications equipment, and airlift capabilities to put viable Pentomic Divisions in the field.

Pentomic Infantry Division, 1 February 1960

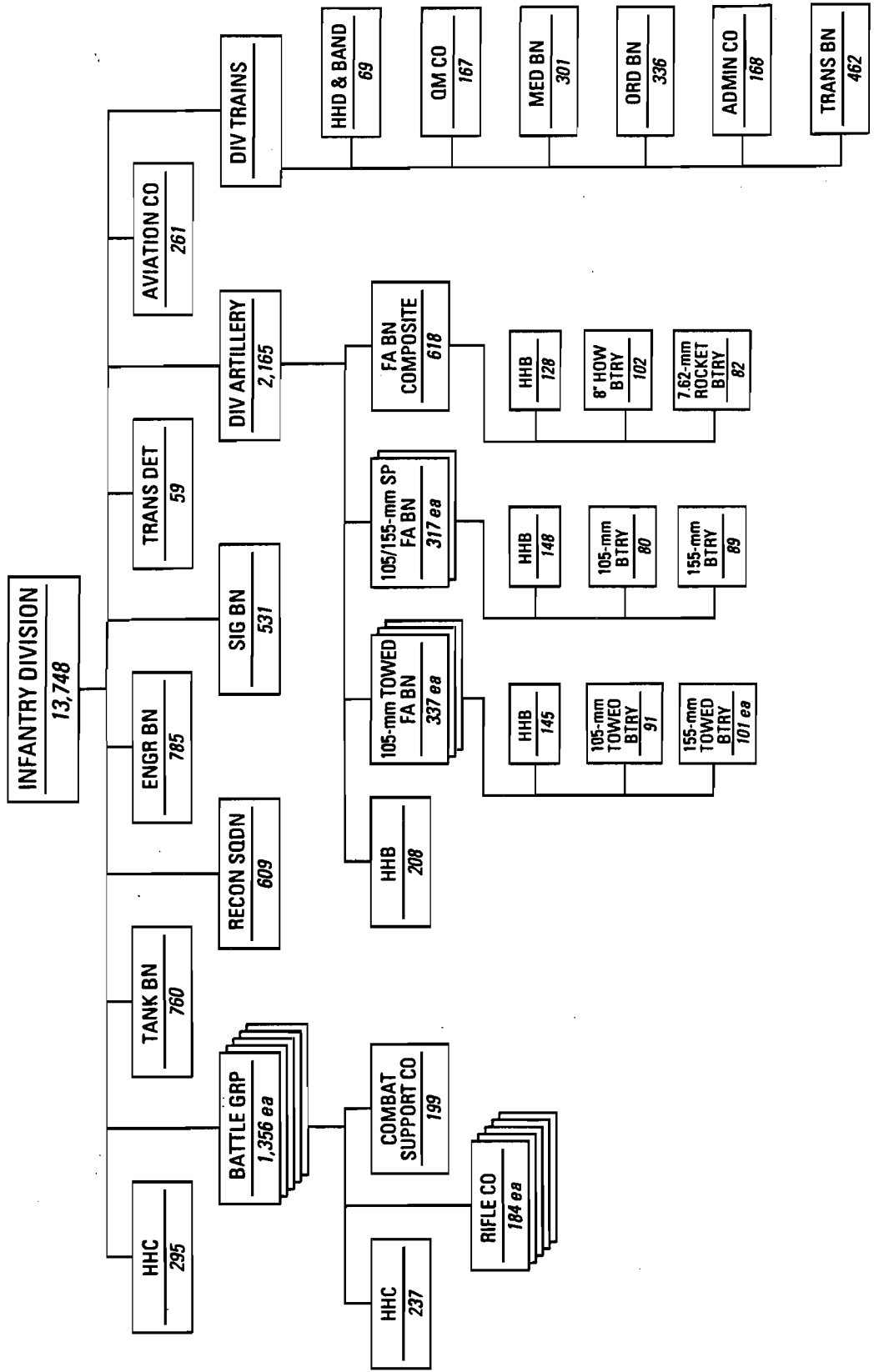

FIGURE 4

# ROAD (REORGANIZATION OBJECTIVE ARMY DIVISIONS), 1960–1963

**BACKGROUND AND PROPOSED UNIT MISSION:** The ROAD division (see figure 5, page 27) was created in an effort to overcome the perceived shortcomings of the Pentomic divisions that existed in the late 1950s (the main weakness of the Pentomic division being that it lacked the combat power to cope with an enemy armored force in a conventional battle). Preliminary division reorganization studies, called MOMAR (Modern Mobile Army), were conducted in 1959–60 but discarded. On 16 December 1960, Vice Chief of Staff of the U.S. Army, General Clyde D. Eddleman, ordered the U.S. Continental Army Command (USCONARC) to carry out a new study of division reorganization. In January 1960, representatives from the U.S. Army Command and General Staff College (CGSC) and branch schools convened at CONARC Headquarters, Fort Monroe, Virginia, to discuss the issue. The reorganization study was then developed quickly by Colonel George Sedbury, Eddleman's protégé at CONARC.

In March 1961, CONARC submitted the completed study, called *Reorganization Objective Army Divisions 1965 [ROAD 1965]*, to Army Chief of Staff George H. Decker. The Chief of Staff and the President approved ROAD reorganization in May 1961 for immediate implementation, but this was delayed by the need to respond to immediate international pressures. *ROAD 65* was sent to CGSC and other schools to develop field manuals (FMs) and tables of organization and equipment (TOEs). In the event, two new divisions were to be formed on the ROAD pattern, the 1st Armored Division [1AD] and 5th Infantry Division [5ID], before other divisions were reorganized. The 1AD was activated February 1962 and ready in August 1962. The 5ID was activated February 1962 and ready in October 1962. Testing of these divisions as they were established served also to test ROAD organization. The rest of the Army's divisions were reorganized along ROAD lines from January 1963 to May 1964.

ROAD divisional organization featured a common support base for infantry, mechanized, and armored divisions. This common base included division headquarters, division artillery, an engineer battalion, aviation battalion, and other support elements. Each ROAD division also had three maneuver combat brigade headquarters. To these could be attached the maneuver battalions, ten for infantry (eight mechanized battalions and two tank battalions) and mechanized (seven mechanized battalions and three tank battalions), eleven for armored divisions (five mechanized battalions and six tank battalions). In principle, only the mix of maneuver battalions differed from division to division. Also, all supply and technical support elements were gathered under one commander for the first time in the division support command, and aviation assets were twice those in the old Pentomic divisions. In combat, the ROAD divisions were task organized: maneuver battalions and other elements were attached as needed to one of the three combat brigade headquarters. Administratively, each battalion reported directly to division headquarters. Brigade headquarters served only to direct maneuver and combat.

ROAD divisions were supposed to have the versatility and flexibility necessary to operate in all environments—against conventional heavy forces in Europe, or against lighter conventional forces or unconventional/guerrilla threats around the world. The divisions were configured to function in a nonnuclear environment but could convert to nuclear readiness if needed. (This was the opposite of the Pentomic division approach.)

**PREPARATORY TRAINING AND UNIT FIELD TESTS:** Close attention was paid to training and testing ROAD, especially in the first divisions adopting it, the 1AD and 5ID. The 1AD was activated at Ft. Hood in February 1962. Preparatory training for 1AD, which amounted to field testing of the ROAD concept, was conducted from March to August 1962, after which 1AD was judged ready. All phases of training took place at Ft. Hood under the division's commander, MG Ralph E. Haines, Jr. Training was conducted first for individuals until they were proficient, then for small units, and finally for large units. In other words, the division carried out in sequence, between March and August 1962, advanced individual training (AIT), basic unit training (BUT), advanced unit training (AUT), divisional and brigade command post exercises, and finally the divisional field training exercises. Training included live-fire exercises at the platoon level. Field testing of every type of unit was formally evaluated: tank and mechanized battalions, the military police company, the aviation battalion, the artillery battalion, the engineering battalion, the signal battalion (and the like), the combat brigade headquarters, and the division as a whole. Detailed questionnaires for evaluators of each type of unit were developed in advance by the U.S. Armor School at Ft. Knox, KY, and submitted to 1AD in June 1962. When evaluation was completed for subordinate units and for 1AD as a whole, the evaluation report was sent up the command chain and distributed to CGSC and to each branch school.

**TEST RESULTS:** In August 1962, Chief of Staff Decker reported to Secretary of the Army Cyrus Vance that 1AD and 5ID had not experienced any significant difficulties that indicated need for change in the basic ROAD concept. Decker's report was subsequent to July reports from the commander of 1AD. The commander of 1AD in July 1962, Major General Ralph E. Haines, Jr., after several months of testing, concluded that ROAD had better flexibility than the old Pentomic divisions and was better suited to oppose guerrillas because it operated twenty cavalry platoons instead of twelve. ROAD, moreover, had better surveillance capabilities than before because of its doubled aircraft assets. The commander gave high marks to the new division support command for handling supply and technical support matters more effectively than in the past. He urged that more vehicles be provided for the artillery units and that radios with greater range and more frequencies be provided for the division. He reported that the division was not yet fully equipped, which was not a problem during *but* because equipment was shifted from unit to unit as each practiced maneuvers; but, he said, this would be a problem during AUT, where all units exercised simultaneously. A number of other problems mentioned in the 1AD July testing report included shortages of armored personnel carriers, radios, tools, aircraft, and surveillance equipment. What is more, evaluators of branch specific units concluded that the Military Police (MP) Company needed another platoon and an organic mess, that artillery battalions needed more vehicles and communication equipment, and the like. But on the whole, evaluators of 1AD believed that

the new ROAD organization was adequate to its missions and more effective than Pentomic division organization.

**TOE REQUIRED RESOURCES VERSUS MTOE MANNING AND EQUIPMENT:** In the July report on 1AD, the commander noted that officers and enlisted troops were about equal to TOE levels. Warrant officers, especially pilots, were at only 66 percent strength, however. The commander also indicated shortages in certain NCO specialties, such as mechanics and radio technicians. Haines stated that 1AD had had to send 1,000 troops to Army technical schools for more training and to train a further 1,300 at schools at Ft. Hood. He urged that military occupational specialty (MOS) needs be better anticipated and the schools' quotas adjusted.

Chief of Staff Decker in his report to the Secretary of the Army observed that staffing of the new ROAD divisions required 2 percent more personnel than the old divisions and that those personnel were not available. At the same time, ROAD organization doubled the number of some weapons systems, but the Army did not yet have the TOE equipment to send to the divisions. The result was that the new divisions would be understrength in personnel and not fully effective until the new equipment arrived. Until then, fixed-wing aircraft would have to serve in place of helicopters, and infantry battalions in place of mechanized battalions.

**TECHNOLOGY ISSUES:** The new ROAD divisions were heavy in technical assets, both armor and aviation related. Commanders during testing reported shortages of technical support personnel, aircraft, vehicles, and other equipment. Evaluators frequently focused on questions of equipment. Usually evaluators' observations took the form of requesting more equipment, notably armored personnel carriers, radios, tools, aircraft, and surveillance equipment. In the case of radios, however, the division commander asked that a different family of equipment be found or developed. He said that battalion-level radios had too limited a range and too few frequencies. Incompatibility of the radios provided to different units was a problem. The twelve-channel very-high-frequency (VHF) radio for the division headquarters was too time consuming to operate to be effective, while its forty-five-foot antenna was too conspicuous.

**IMPACT ON UNIT READINESS:** Commentators did not emphasize detrimental readiness in the ROAD conversion. Note, however, that initial ROAD experimentation and testing was done with newly formed divisions that had no readiness to lose, that earlier formed divisions were reorganized only after initial testing was completed, and that general reorganization was delayed for two years until there was relatively less likelihood of immediate need for their operational deployment .

**OPERATIONAL/WARTIME VALIDATION:** ROAD, a variation of the World War II armored division, was the standard division configuration between 1962 and 1983, when it was replaced by the Army of Excellence model. It was the division with which the Army went to war in Vietnam.



**INSIGHTS GAINED:** The ROAD reorganization project seems on the whole to have been carried out effectively. Contributing to this outcome were careful planning, mobilization of planning resources at branch and staff schools at several points, systematic testing and evaluation, and an implementation schedule that was timely but not hasty. ROAD reorganization was facilitated also by an increase in authorized Army strength in 1961–63 of 31,000 troops (from 929,000 to 960,000 authorized). This made possible the formation of the two new ROAD divisions. Army budgets were also increased from 1961–63 by 12 billion dollars.

# ROAD Division Base, 1961

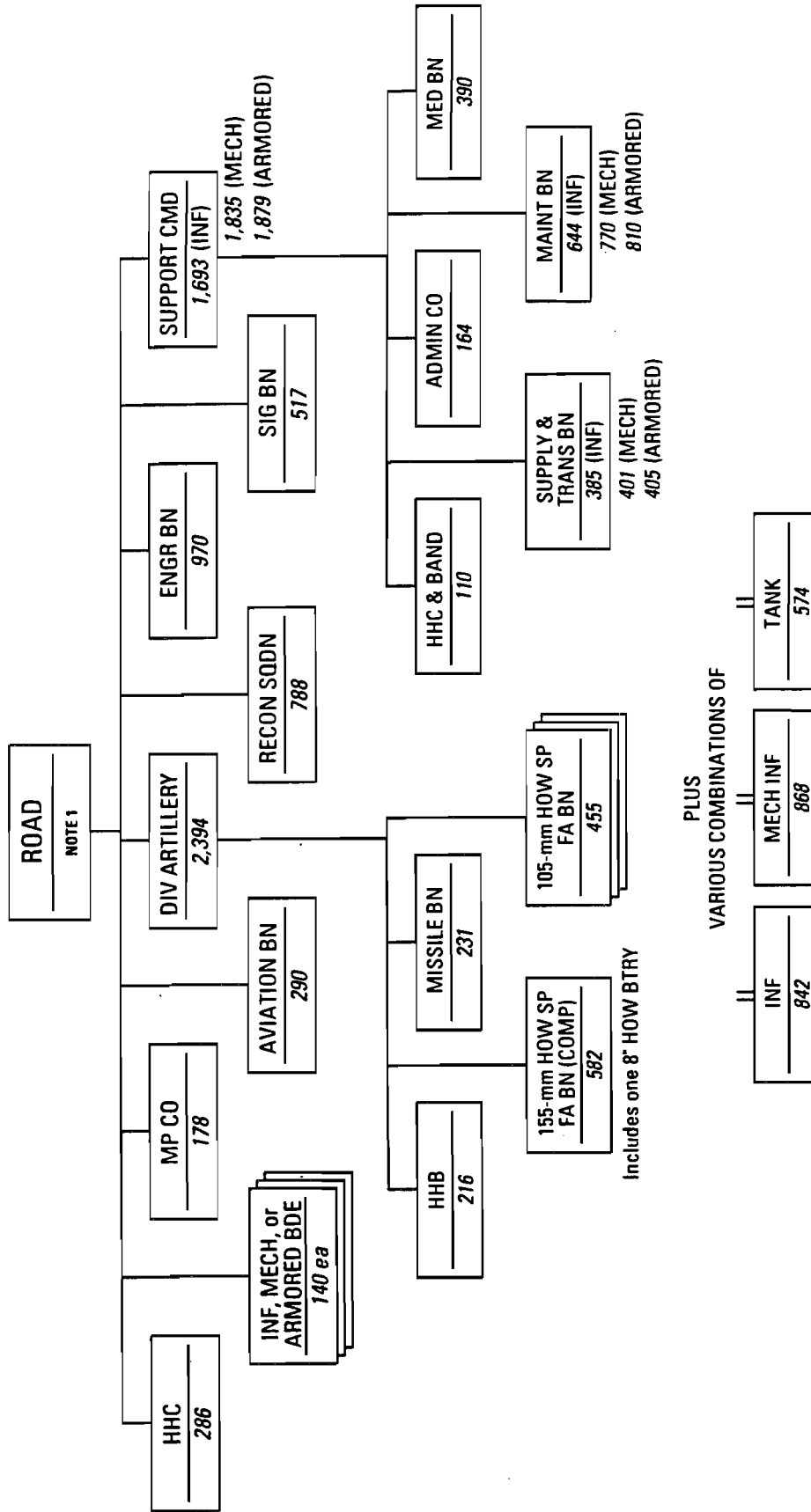

NOTE 1 Strength will vary depending on the combination of maneuver elements assigned.

FIGURE 5

## 11TH AIR ASSAULT DIVISION (TEST), 1963–1965

**BACKGROUND AND PROPOSED UNIT MISSION:** After losing its organic air power to an independent Air Force in 1947 and then losing tactical air support to strategic bombing tactics, the Army looked for ways to use its aviation assets to increase mobility and close air support. By the mid-1950s, the Army Aviation School at Fort Rucker was conducting experiments and improvising the mounting of guns and rockets on helicopters and devising ways to use them tactically to improve the ratio between manpower and firepower on the potential nuclear (and, thus, dispersed) battlefield. After his appointment in 1961, Secretary of Defense Robert S. McNamara assigned his staff to review the Army's aviation needs and requirements. He believed the Army's previous attempts had been too limited and conservative; therefore, he instructed the senior leadership to examine aviation in a new light and to be more audacious in using it, writing: "I shall be very disappointed if the Army's re-examination merely produces logistically oriented recommendations to procure more of the same, rather than a plan for employment of fresh and perhaps unorthodox concepts which will give us a significant increase in mobility." In 1962, the Howze Board recommendations called for the Army to recognize that drastic force structure changes would be necessary to "accommodate the near revolutionary change in land combat tactics and doctrine" implied by the extensive use of the helicopter (see figure 6, page 32).

**PREPARATORY TRAINING:** The 11th Air Assault Division (Test) was formed on 15 February 1963 as a tactical training and experimental test bed at Fort Benning. The division commander began by organizing one battalion and picking a few men to form a brigade staff. Few had any knowledge of helicopters, and the division was so small that it had to borrow elements from the 2 ID to conduct exercises. At the same time, the 10th Air Transport Brigade was created around an existing aviation battalion at Fort Benning. Like the rest of the division, the brigade's aviation assets came from the entire Army.

The test units were under the direct control of U.S. Army Continental Command (CONARC) for organizational and training purposes. The Combat Developments Command (CDC) supervised the developing and implementing of the appropriate tests and evaluations. The test director was the Commanding General (CG), Infantry Center, Fort Benning. The Test Evaluation and Control Group there established a methodology to evaluate the combat systems and the ways they interacted with each other. The biggest problem they faced was deciding what could and should be tested. The test cells began to develop procedures, tactics, and techniques to use throughout the test cycle. Changes occurred daily, complicating the need for the testing units to train themselves while testing. There were neither texts nor standard operating procedures (SOPs) to help the Test and Evaluation Group, just as there were none for the division executing the test. All had to be created as the division and test bed grew.

**UNIT FIELD TESTS:** The first phase, Air Assault I, which began in September 1963, tested a C2 system that used a flying command post (CP). A helicopter equipped with radios

capable of communicating with ground units carried the brigade commander, an artillery liaison officer, a forward air controller (FAC), and the brigade operations officer. The troops used included a field battalion and a skeleton brigade headquarters (HQ), which simulated the brigade and division staffs. The test objective was to develop a sequence of steps necessary to achieve surprise and massive offensive firepower for an assault. Techniques tested included assault doctrine, methods of formation flying, the use of aerial artillery to suppress hostile fire in landing zones, the maintenance of air lines of communication, and ways to control airspace over a target area.

The second phase, Air Assault II, a division field exercise at Fort Bragg, began in October 1964. It pitted the division, still missing one brigade (simulated for the exercise), against the 82d Airborne Division. It included various controlled maneuvers designed to collect necessary testing data.

**TEST RESULTS:** Air Assault I showed that an airmobile brigade land battalion HQ could handle the required jobs without division teams to integrate firepower and coordinate air operations. Air Assault II concluded that the division had limitations and strengths. The former included poor ground mobility, vulnerability to armored attacks, and operational vulnerability to bad weather and extended operations. The latter included excellence in high-tempo operations, long-range capability, and flexibility to fight simultaneously in different directions and to conduct operations without a reserve, using air mobility to concentrate its forces at critical points. One surprising test result was the division's capability for resupply by air. Air Assault II showed that an airmobile brigade could seek out and destroy an enemy over a wide area. In a low-intensity war, it was thought, the division could control large sectors of countryside. In a medium-intensity war, it would function as an unparalleled reserve screening force. The Army planners also believed that the test proved the cost-effectiveness of an airmobile division. In addition, the test director reported that integrating Army aircraft into the ground units provided crucial maneuver capability for light mobile forces to close with and destroy the enemy.

**TOE REQUIRED RESOURCES VERSUS MTOE MANNING AND EQUIPMENT:** As originally conceived, air assault divisions would resemble ROAD divisions and have sufficient aircraft to lift 33 percent of the division's combat elements at once. The division would have some fixed-wing aircraft, but most would be in an air transport brigade, a nondivisional unit, to reinforce the division's transport capabilities. The board suggested that the new division use new, lighter 105-mm howitzers, Little John rockets, and air-to-ground rockets on helicopters to replace 155-mm howitzers. Infantry would be relieved of all burdens except those associated with combat. The board estimated the division would require between 400 and 600 aircraft, but ground vehicle requirements fell from 3,400 to 1,000.

The 1st Cavalry Division (Airmobile) was configured differently from the test unit. It had neither a Little John rocket battalion nor an attack helicopter battalion. The division fielded an aviation group (a general aviation support company and one assault and two assault

aviation battalions). There were 335 division helicopters. The division was authorized 1,500 ground vehicles (half the number of a ROAD division) to move supplies, artillery, antitank weapons, and help in ground reconnaissance. The airmobile infantry battalion had one combat support company (reconnaissance, mortar and antitank resources) and three rifle companies.

**TECHNOLOGY ISSUES:** These issues revolved around the Army's use of aviation assets and the Air Force opposition to this use. The Army used this test bed to experiment with new air assault and air mobility doctrine. It tested new radio equipment, the use of helicopters to replace other road-bound forms of mobility, as well as new tactical configurations. New weapons systems and tactical configurations, not new technology *per se*, were the issues tested.

**IMPACT ON UNIT READINESS:** By direct instruction from the Secretary of Defense, the 11th Air Assault Division (Test) was specifically formed as a test unit in order to test the air mobility concept. It did not appear as an active division. As the written material about testing indicates, it was never at full strength as a division. The closest it came was in an Air Assault II test, when it consisted of two brigades and simulated its third brigade.

**OPERATIONAL/WARTIME VALIDATION:** The Vietnam War provided a laboratory for testing some of the 11th Air Assault Division's ideas and equipment. The division created and maintained a bond with units deployed to Vietnam by showing interest in their experiences. Many of the division's soldiers came from Vietnam and returned there to discuss ideas and techniques with units already deployed. The test itself received an added mission to form, equip, and train six airmobile companies to send to Vietnam. It also provided leadership continuity for the 1st Cavalry Division (Airmobile) when it deployed to Vietnam.

After receiving the Army's recommendation to establish an airmobile division, the Secretary of Defense announced its activation on 28 June 1965. The 1st Cavalry Division (Airmobile) was officially activated on 1 July 1965 and was composed of the 11th Air Assault Division (Test), the 10th Air Transport Brigade, and elements of the 2d Infantry Division. The new division was ordered to Vietnam on 28 July 1965. In less than one month, it was organized and prepared for combat.

**INSIGHTS GAINED:** The 11th Air Assault Division (Test) was important because it developed methodology for future Army testing and development architecture. The lasting elements were the techniques, procedures, and organizations created and used to develop force structure and to test new equipment. The test enabled development of proponency between the test and evaluation community and the tested unit. It also allowed for greater military and civilian cooperation at the user level, especially in incorporating new technology into existing or new organizational structures.

On the other hand, the division's creation isolated and divided the armed forces' senior leadership. The Secretary of Defense directly intervened in the process to start it and to give

support to the aviation insurgents. Without his initial direction and support, they would have been unable, as they had been in the past, to overcome their opponents in the Army and the Air Force. The bitter interservice rivalry and bickering that characterized the joint test continued for another twenty years.

The test provided a valuable leadership continuity lesson because the most knowledgeable and motivated men directed it at each level. It also provided leadership continuity for the 1st Cavalry Division (Airmobile) when it deployed to Vietnam. Support at the highest level was necessary when interservice rivalry threatened the idea of air mobility. These rivalries also increased costs and bureaucracy. This was evident in the need for follow-on tests. However, the most enduring results are the Army's existing test and evaluation framework.

Howze Board—Air Assault Division, 1963

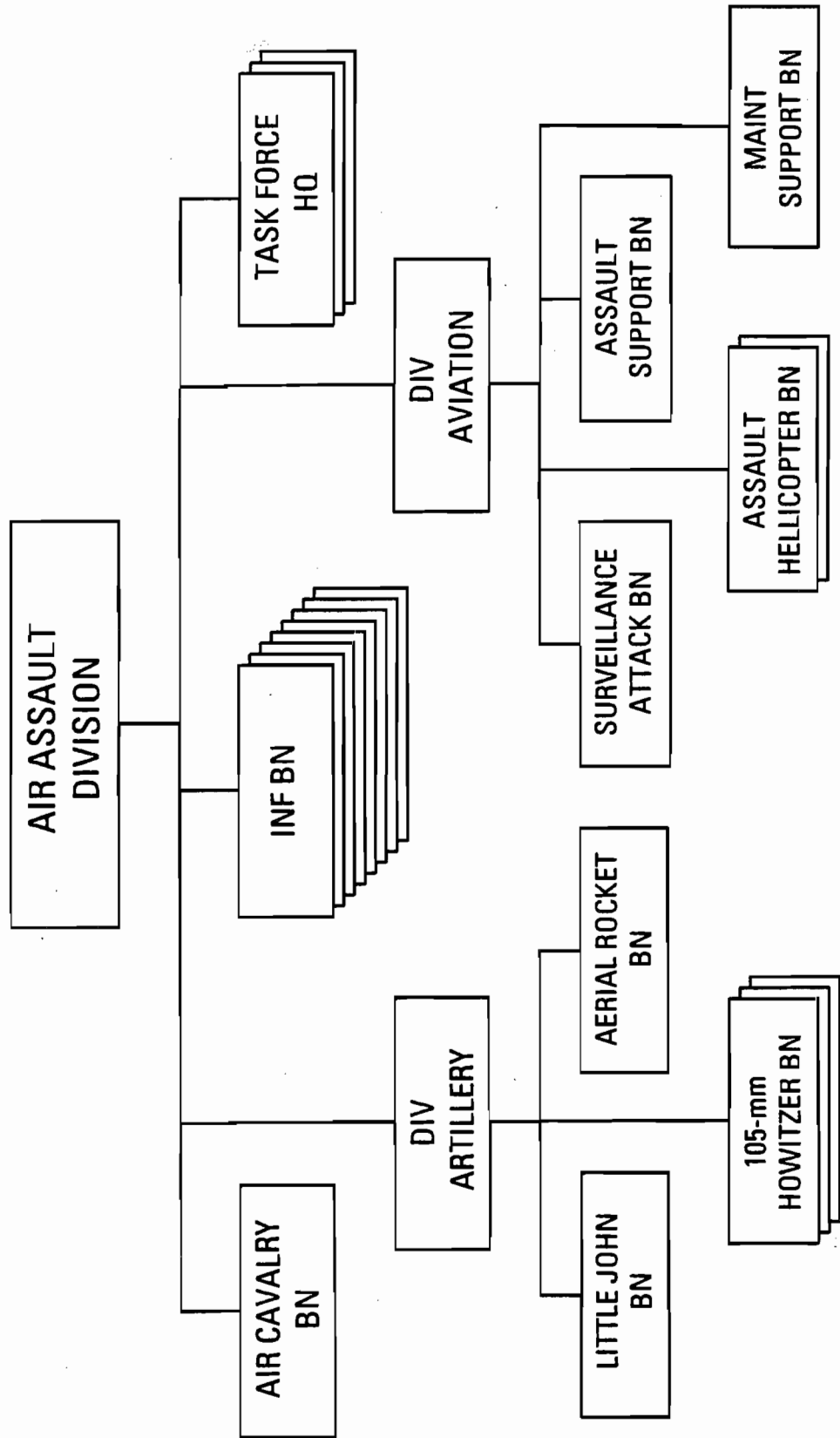

FIGURE 6

# 1ST CAVALRY DIVISION (TRICAP), 1971–1974

**BACKGROUND AND PROPOSED UNIT MISSION:** After seven years in Vietnam, the Army was beginning to reform itself to face the Soviet threat in Europe and the eastern Mediterranean and to revitalize its NATO connections. It would take the combat lessons the Army learned in the various terrains in Vietnam to produce the impetus to create new force configurations to fight against potential Soviet threats.

Between 1972 and 1974, the Army tested a variation of the ROAD division. Leading up to the test, the 1st Cavalry Division (TRICAP) was activated at Fort Hood, Texas, on 5 May 1971 (see figure 7, page 36). The TRICAP (triple capability) concept combined an armored brigade (for its fire power, mobility, and shock action), an airmobile infantry brigade (to serve as a fixing force with tactical and operational mobility), and an air cavalry combat brigade (for its combination of aerial firepower with tactical and operational mobility) into a single division. *Army* magazine reported, “Technically, we are combining an airborne tank-destroying force with a ground armored force.” The concept was designed to apply the latest technological advances to military techniques and tactical requirements to increase combat power. It would impose new technology on what was then current doctrine. The idea was to extend the airmobility experience from Vietnam to the midintensity combat environment expected in Europe and the Middle East. It was thought that the division would provide a foundation for the future Army that would be modified by tests scheduled for 1971–72.

**PREPARATORY TRAINING:** Field testing began in February 1972. The experimental division was formed from elements of the 1st Armored Division and the 1st Cavalry Division (Airmobile). The 1st Cavalry Division replaced the 1st Armored Division in the force structure and became part of III Corps. Meanwhile, the 1st Armored Division was sent to Europe to replace the deactivated 4th Armored Division. Completion of the TRICAP division evaluation was supposed to occur in FY 73.

The TRICAP division consisted of 13,500 officers and men organized into an armored brigade, an airmobile brigade, and an air cavalry combat brigade. The latter consisted of one squadron of air cavalry (Vietnam organization) and one squadron of new air cavalry, described as a “mobile and flexible antitank force.” Ultimately, it would be equipped with attack helicopters carrying TOW antitank missiles.

The Department of the Army (DA) established two programs to evaluate the division and the air cavalry combat brigade. On-site testing was conducted under the Modern Army Selected Systems Test, Evaluation and Review (MASSTER). The object was to adapt and apply airmobile experiences from Vietnam to different battlefield environments.

**UNIT FIELD TESTS:** The Air Cavalry Combat Brigade Test (ACCBT), beginning in August 1971, tested the air cavalry attack platoon. The ACCBT was designed to evaluate the use, capabilities, and effectiveness of the platoon under continuous combat operations. The



TRICAP program was designed to test the operational effectiveness of various tailored company teams that were parts of battalion task force organizations and investigate the employment of air cavalry and attack helicopters with company-sized armor and mechanized and airmobile elements. The simulated combat environment was a mid-intensity European war.

The test program was managed by the Surveillance, Target Acquisition and Night Observation (STANO) Systems Manager. Created by DA on 15 September 1969, it received managerial responsibility for TRICAP and MASSTER in February 1971. The MASSTER project director was the Commanding General, III Corps, Fort Hood, Texas.

As the STANO test bed, Project MASSTER had Army-wide implications. Initially, the tests did not include major force design issues related to combat forces, but this changed as the project embraced the TRICAP concept. The presumed triple capability of a division containing Armor, Airmobile, and Air Cavalry organizations in mid- to high-intensity warfare was attractive. TRICAP was superimposed on Project MASSTER from its beginning to avoid creating another test organization. It remained under CONARC and responded to DA direction. In August 1972, the department added another agency to the mix, the Combat Developments Command (CDC). It would coordinate with CONARC and the Army Matériel Command, establish test objectives, evaluate test results, and make recommendations directly to the DA.

Many believed the TRICAP test would demonstrate a revolutionary increase in combat power. They hoped test results would confirm TRICAP as the best combination and size of combat elements and simultaneously demonstrate the cost-effectiveness of the TRICAP division as a general-purpose unit. The division was under considerable pressure to remain combat ready to fulfill its mission to reinforce NATO. The mission to reorganize to deploy would be accomplished with a roundout reserve brigade in case of an emergency.

**TEST RESULTS:** The test and evaluations determined the division had distinct disadvantages when compared to other divisions in attacking and defending. It also pointed out that the division needed better C<sup>3</sup> and support systems to synchronize combined arms operations involving the Army fielded helicopters, antitank systems, new target-acquisition systems, and a new generation of armored and mechanized vehicles.

In December 1972, CDC produced an interim recommendation to increase the TRICAP division's size to 16,000 officers and men. This made it more closely resemble a standard armored division and reduced its airmobile assets. Other studies suggested the need for more artillery to support aerial combat operations, while the antitank emphasis in the division was praised. The testing did not conclusively settle the question of whether the air cavalry combat brigade performed better in a division or as an independent unit. Forming the independent 6th Cavalry Brigade was the result of a consensus for further study (as the larger test concluded inconclusively).

The 1973 Yom Kippur War jarred the Army into adding more heavy divisions to the force structure. As the result of a CDC evaluation, the division would be reorganized late in FY 74 with two armored brigades and an air cavalry brigade. In March 1974, the Department of the Army announced a revision of the force structure for FY 75–80. The 1st Cavalry Division was reorganized as an armored division, and a separate 6th Air Cavalry Brigade was formed.

**TOE REQUIRED RESOURCES VERSUS MTOE MANNING AND EQUIPMENT:** The TRICAP division consisted of 13,500 officers and men organized into an armored brigade, an airmobile brigade, and an air cavalry combat brigade. On 23 November 1970, the organization was approved by the Army Chief of Staff, General William C. Westmoreland. Because the Army was unable to retain the 1st Cavalry Division and remain within the authorized thirteen-division force structure, the redesignation briefly described above occurred. The Army could not afford to maintain a divisional test unit with the force reductions enacted in the declining days of the Vietnam War.

**TECHNOLOGY ISSUES:** No new technology issues were broached in this experiment; it was simply a matter of providing improvements to what was already available. The technology issues concerned command, control, and computers and concentrated on augmenting and improving technology proven effective in Vietnam.

**IMPACT ON UNIT READINESS:** Given the manpower constraints mentioned in the previous paragraph, the disassembling and reassembling of the division caused degradation in unit readiness. Testing the different combinations of equipment and reforming soldiers from two separate divisions into a single division had a detrimental effect on unit readiness.

**OPERATIONAL/WARTIME VALIDATION:** The division design was never made operational or tested in combat.

**INSIGHTS GAINED:** The TRICAP Division lacked strong institutional support and a threat-based requirement necessary to keep it viable. The pressure to subject a unit that still belonged to the thirteen-division force structure to tests also caused problems. Expecting a unit to maintain combat readiness and accountability, to operate as a test unit, and to be prepared to deploy showed a flawed testing plan from the start. The Yom Kippur War reinforced a decision to add more heavy divisions to the Army and end the test. In many ways, the insights gained were indirect, such as those that resulted in establishing the independent 6th Cavalry Brigade.

The TRICAP Division failed but did have an impact on the Army. Overall, however, the results of the tests were disappointing. The experiment concluded that the TRICAP division needed more tanks and less airmobile infantry. It lacked the heavy combat power needed to fight on a NATO battlefield. After the Vietnam War, the Army eschewed forces that could not support its primary mission of NATO defense.

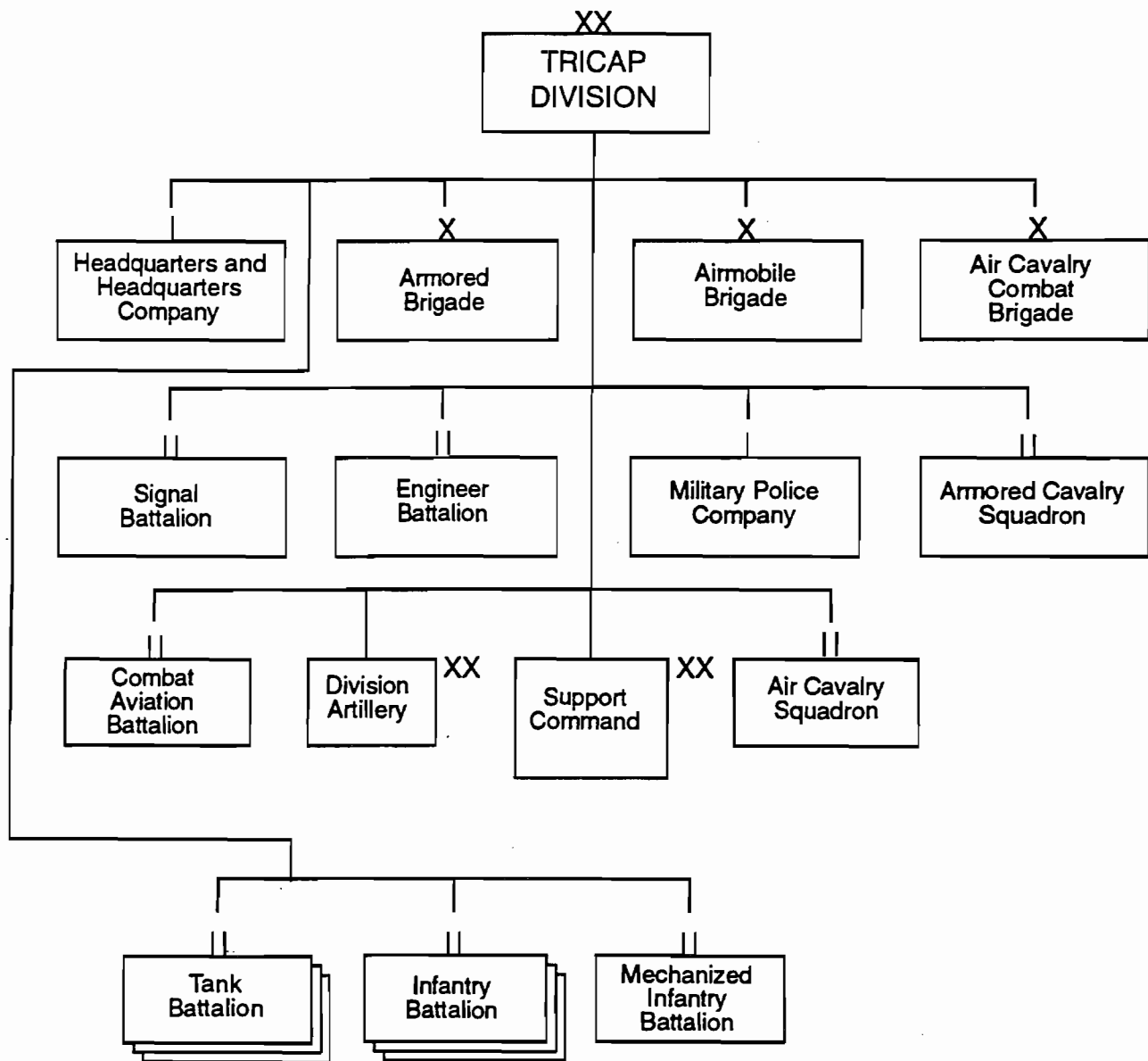

FIGURE 7.

# DIVISION RESTRUCTURING STUDY (DRS), 1975–1979

**BACKGROUND AND PROPOSED UNIT MISSION:** In mid-1975, TRADOC began to analyze the current Army division's suitability to meet the Warsaw Pact challenge. The planners realized that more was needed than adjusting and adapting the basic division design. In October 1975, General William E. DePuy, TRADOC Commander, wrote to General Frederick C. Weyand, Army Chief of Staff, suggesting that the Army base unit organization on weapon systems and tactics. In March 1976, the Department of the Army directed the Training and Doctrine Command (TRADOC) to undertake a formal restructuring effort, and on 4 May 1976, General DePuy formed a special Division Restructuring Study Group under his direct control. He was particularly concerned that force design reflect the new generation of improved equipment the Army expected to receive in the early 1980s.

The DRS recognized that the ROAD organization made inefficient use of 1970s weaponry and voiced concern that ROAD could not handle the weapons programmed for the 1980s (see figure 8, page 40). Also, the ROAD design could not keep pace with tactical changes emerging from weapons advances like the antitank missile. The study was supposed to determine the best size, mixture, and organization of armored and mechanized infantry divisions for the early 1980s.

Weapons systems and the best mode of employing them would determine force design. DRS would integrate new weapons to ensure their ideal use when and where they were most needed. Trends in firepower and personnel employment over the last hundred years were key to any design. The 1983 mechanized division would have six times the combat power of its World War II predecessor. Simultaneously, indirect fire techniques and air-delivered munitions greatly increased the demands on battlefield commanders as they attempted to integrate all elements of the combined arms battle. Greater troop dispersion required greater mobility to mass defenders quickly at a threatened breakthrough point. The increasing complexity of war demanded more combat service and combat service support to supply and maintain the troops and the new weapons, continuing a trend of increasing the size of the Army's logistical tail.

Planners identified a number of institutional problems facing contemporary divisions. Already overburdened company commanders had to integrate fires of the combined arms team on the battlefield, despite the inexperience of these officers. Artillery was outnumbered by Soviet guns and insufficient for a modern battle. The engineers' missions were too diversified and did not focus on mobility and countermobility. Weapons were being added to existing organizations, even if this meant inefficiently employing men and matériel. The Army had to switch from traditional organizations that integrated new systems into existing units to a system that aligned combat and support organizations toward particular weapons systems.

On 16 July 1976, TRADOC briefed General Weyand on the pilot study for a proposed heavy division. General Weyand endorsed the concept for further discussion, evaluation, and testing. Many of the ideas were innovative, some controversial, and a number of the recommendations would eventually be adopted by the Division 86 study. A DA staff critique favored testing. The reviewers had strong reservations about General Weyand's proposal for a one-year test in 1977-78. They favored a longer, four-year study and a slower restructuring pace to allow new weapons to be integrated into the redesigned divisions as the systems became operational.

**PREPARATORY TRAINING:** On 24 January 1977, General Bernard W. Rogers, the new Chief of Staff, approved the original testing concept with the 1st Cavalry Division at Fort Hood, Texas, as the primary test unit. Fresh from the TRICAP experiment, which ended in 1974, the division had been reconfigured as an armored division. For this test, one brigade of the division was selected as the test bed.

**UNIT FIELD TESTS:** The field tests were undertaken by the brigade at Fort Hood in 1979. The test director was the III Corps commander. The tests were held under rules established by General DePuy but occurred after General Donn A. Starry became the TRADOC commander. But the tests could not use the weapons around which the design was constructed because, scheduled to enter into service three years later, they were terminated before they were completed.

**TEST RESULTS:** Not unexpectedly, the tests, called the Division Restructuring Evaluation, yielded mixed results. The test director reported that the division was overmanned and overequipped in many areas. Although this gave commanders resources to meet every possible contingency or deficiency, the test director thought the personnel and equipment costs would make the division too expensive to field.

Critics reported the tests, which supported the three-tank platoon, were flawed. Units improperly trained in the new three-tank tactics exercised against opposing forces that were poorly trained in obsolete Soviet tactics, under poor control, and operated under improper conditions to assure the validity of test data. Strong support did emerge for the brigade organic battalions, integration of combined arms at battalion level and below, single-purpose maneuver units, and cross attachment at company level, which was thought to be an option worth retaining. Yet serious doubts remained: the three-tank platoon was too small (a four-tank platoon was superior to either the five- or three-tank variety); the division depended too much on external combat service support and lacked scouts in its maneuver battalions (it was believed that scouts were necessary at both battalion and brigade); and the brigade's span of control was too large. But four firing batteries of eight howitzers each were superior to the three-by-six structure. Finally, the ROAD TOE updated with weapons available in 1986 was better and more cost-effective for the offense, but the new DRS TOE was better and more cost-effective for the defense. In short, features of both the current and the restructured division warranted inclusion in any new design for a heavy division.

**TOE REQUIRED RESOURCES VERSUS MTOE MANNING AND EQUIPMENT:** A single brigade was tested, not an entire division. The test director found it was overmanned and overequipped in many areas.

**TECHNOLOGY ISSUES:** The technology issues concerned radios, which had proliferated so much that their use hampered rather than improved communications. Other issues tied to technology, such as the inadequacy of air defense and the way the bifunctional staffs filtered information, also emerged.

**IMPACT ON UNIT READINESS:** Throughout the test period, there was tension between the division's role as a test bed and its role as a deployable unit. As in the TRICAP experiment, disassembling and reassembling a brigade of the division caused degradation in unit readiness.

**OPERATIONAL/WARTIME VALIDATION:** The division design was never made operational or tested in combat.

**INSIGHTS GAINED:** The DRS shared several characteristics with the Active Defense Doctrine and suffered from the same problems. It reflected General DePuy's drive and insight and was created by a small group working under his direct supervision. TRADOC did not staff the force design to its own schools and centers before seeking the Army Chief of Staff's approval. Consequently, the study did not have the benefit of their wisdom, and they felt no responsibility for the design. General Starry, who succeeded General DePuy as TRADOC commander, disagreed with both the study's results and methodology. General DePuy's desire to field a new force design quickly inspired accelerated and nonstandard testing, which left many questions unanswered.

Before the tests were concluded, General Starry launched Division 86 to build on the DRS and its tests. In July 1979, the Department of the Army followed TRADOC's lead and formally absorbed the Division Restructuring Study into Division 86. The motivation behind DRS was to organize divisions in line with new, more effective weapons systems and emerging tactical doctrine. General DePuy's and the DRS planners' overriding concern were the increased battlefield lethality demonstrated in the 1973 Yom Kippur War. This led them to emphasize the tactical level. Before they could implement their ideas, however, a new TRADOC commander with a different focus overtook their study with a more detailed, organized, and broader-based approach to the problems of force design for the modern battlefield.

# DIVISION RESTRUCTURING STUDY (DRS) DIVISION (1976)

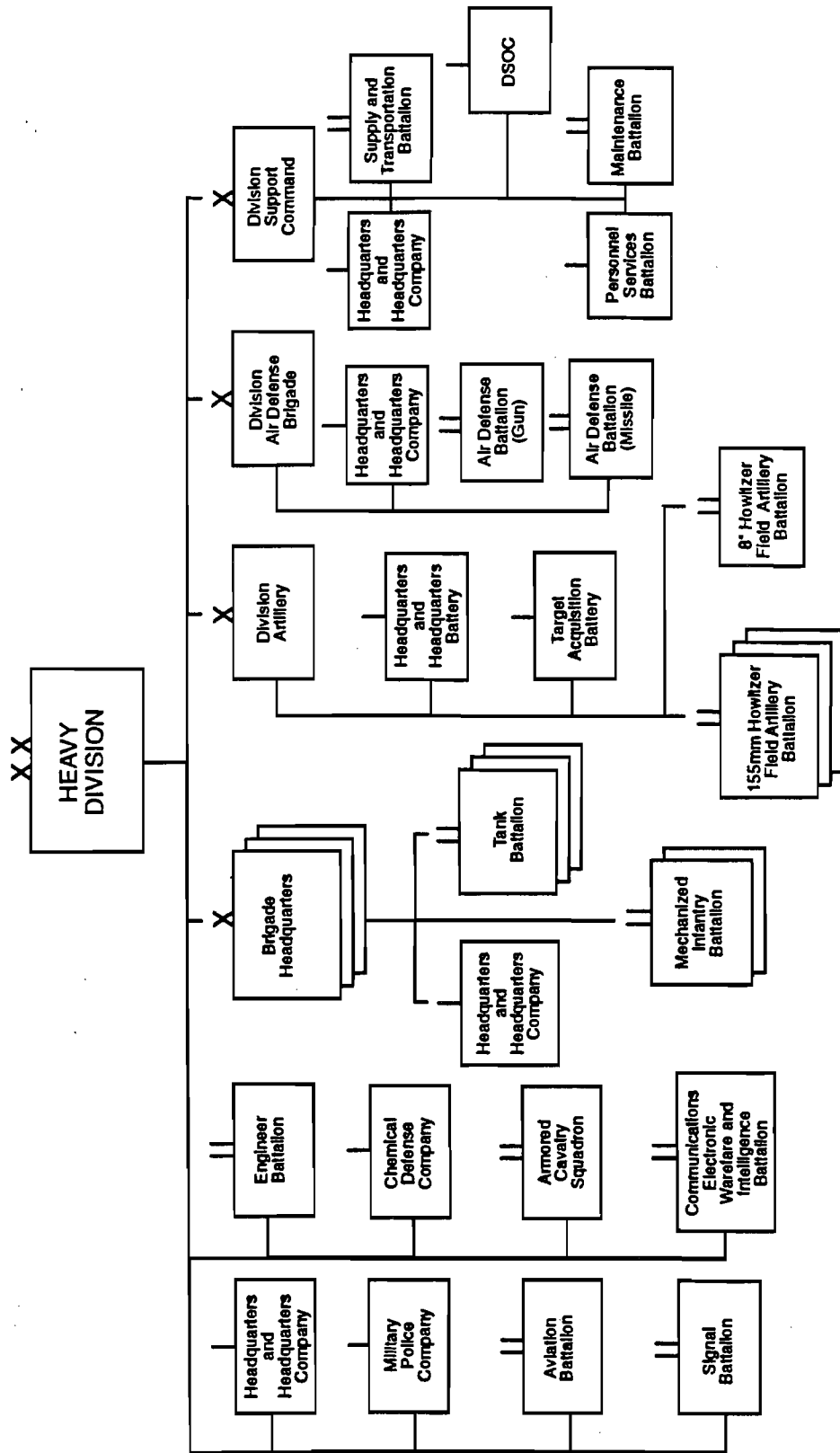

FIGURE 8

## DIVISION 86, 1978–1980

**BACKGROUND AND PROPOSED UNIT MISSION:** General DePuy's successor at TRADOC, General Donn A. Starry, replaced the DRS with a more detailed approach and sought wider Army approval for the resulting force design before the 1st Cavalry Division completed the Division Restructuring Evaluation. Based on his experience as V Corps commander in Europe, he believed the DRS was done too quickly, by too few people, and with too little analysis. Units conducted tests without proper training, and the opposition lacked up-to-date knowledge of Soviet tactics; therefore, the test results were flawed.

General Starry believed the Army should create force designs the same way it created equipment and doctrine, around a vision of the battlefield. He believed that once the Army identified the functions it wanted in a unit, it could then study itself as well as the perceived threat to determine what was needed. This approach purposely eschewed a branch orientation and was later formally called the Concept Based Requirements System (CBRS). Although it was introduced near the end of Starry's command tour at TRADOC, its approach governed the Division 86 force design process. Division 86 was so named because 1986 was as far in the future as the Army's senior leadership could project the Soviet threat (see figure 9, page 44).

Division 86 was the best-orchestrated, elaborate, and thorough division-design effort conducted. When he announced the new design initiative at the 1978 TRADOC Commander's Conference, General Starry described it as building on DRS and permitted doctrine, organization, training, and training literature to focus on new weapons and equipment. He tasked the Combined Arms Center (CAC) at Fort Leavenworth to coordinate service school efforts in preparing the Division 86 matériel systems and TOEs. The schools and centers became proponent agencies, conceptualizing various functions and tasks within the design.

The fundamental approach began by defining the division's specific tasks and functions, designing organizations to meet those demands, and combining the units into a coherent whole. School and center task forces fleshed out potential unit organizations, which CAC analyzed in various division combinations. Periodic general officer meetings provided input, guidance, recommendations, and approval to the actions by task forces and CAC, while sorting out unresolved conflicts among the designers. To counter the Soviet threat in Central Europe, the force designers concentrated on the heavy division.

**PREPARATORY TRAINING:** No unit was designated as a test bed.

**UNIT FIELD TESTS:** None.

**TEST RESULTS:** None.



**TOE REQUIRED RESOURCES VERSUS MTOE MANNING AND EQUIPMENT:** The heavy division was designed to have flexibility, mobility, strength, and resiliency to withstand and defeat the echeloned attack of Warsaw Pact armies. Superficially, it resembled the ROAD design. It consisted of a 19,855-man division (armor), with a division headquarters, headquarters company (HHC), three brigade headquarters, combat maneuver elements, a division support command, a reconnaissance squadron, division artillery, and other support and combat service support companies and battalions. However, it differed significantly from ROAD.

A fourth brigade-sized headquarters and an air cavalry attack brigade (ACAB) united all divisional aviation. Tank and mechanized battalions had a new organization. The former were organized with an HHC and four tank companies. Each company consisted of three tank platoons, each with three tanks. The latter had an HHC, a TOW antitank company, and four companies of three platoons of three squads each. Division artillery had increased firepower: three 155-mm battalions with three batteries of eight guns each, one battalion of 16 eight-inch howitzers, and nine general-support rocket system launchers (MLRS). The reconnaissance squadron was smaller and had a more limited mission, and the engineer battalion was more mobile, with consolidated armored vehicle launched bridges (AVLBs). The air defense battalion consolidated all the division's Stinger anti-aircraft missiles, while the Division Support Command (DISCOM) placed critical battlefield support functions in three battalions to provide direct support to maneuver brigades.

The plans for Division 86 used more than forty major weapons or new pieces of equipment that had not been procured yet. Some were still in the developmental stages. The solution proposed by DA was to adopt the concept but continue with interim organizations using obsolete equipment until the new matériel became available.

On 1 August 1980, Army Chief of Staff General Edward C. Meyer approved implementation of the newly designed heavy division. The armor division of six armor battalions and four mechanized battalions would be 19,966 men strong, the mechanized division of five armor and five mechanized battalions would be 20,250-men strong.

The Army faced a personnel shortfall in fielding Division 86. TRADOC estimated that it would require 836,000 soldiers to field Army 86, but Congress authorized only 780,000 for the foreseeable future. Because of this manpower problem and difficulties experienced in funding and procuring new equipment, modernizing the heavy divisions was delayed for ten years.

**TECHNOLOGY ISSUES:** There were no technology issues to address *per se*. The planned division would not exploit any technological breakthroughs. The new equipment was to be improved versions of what already existed.

**IMPACT ON UNIT READINESS:** None. There was no test unit.

**OPERATIONAL/WARTIME VALIDATION:** The division design was never made operational or tested in combat.

**INSIGHTS GAINED:** Several reasons were advanced for developing Division 86. First was the need to provide units to support new equipment, increase the leader-to-led ratio, and adapt to the anticipated rapid pace of future combat.

Division 86 was also shaped by the probable area of conflict. The Army moved away from its traditional, generic, flexible division design to meet a specific foe in a specific area.

Doctrine was another consideration. This was probably the first time that an emerging doctrine played a major role in a force design effort. AirLand Battle doctrine was not officially endorsed until after Division 86 was approved, but General Starry began developing the division to match his doctrinal ideas. The new doctrine developed concurrently with the design effort, and each theoretically nurtured the other. His doctrinal concepts and vision of future Army doctrine provided the impetus for the new heavy-division design. Doctrine joined demands for modernization, leader-to-led ratios, and the expected theater of battle as factors prompting the design of a new heavy division.

General Starry recently observed that the final Division 86 design was the result of many compromises and did not resemble the original concept. He commented that although nothing tangible came from DRS, the Division 86 studies were built on its foundation. The Yom Kippur War demonstrated that the battlefield had radically increased in size, tempo, and lethality. With the larger battlefield and increasing tempo, the Army had to begin thinking at the operational level.

He stated that, conceptually, the Division 86 organization was established correctly, but that internal Army politics forced compromises and, in the end, produced a larger rather than smaller division. From his experience, he concluded that Army managers lost sight of the reorganization's original purpose, and that doctrine should outweigh internal politics and policy. In the end, Division 86 was not light enough to deploy and not heavy enough to fight heavy forces in open terrain. Attempting to meet both requirements prevented the design from succeeding. However, the Infantry Division 86 design was the basis for the Army's later search for a viable light division.

# Heavy Division, 1 October 1982

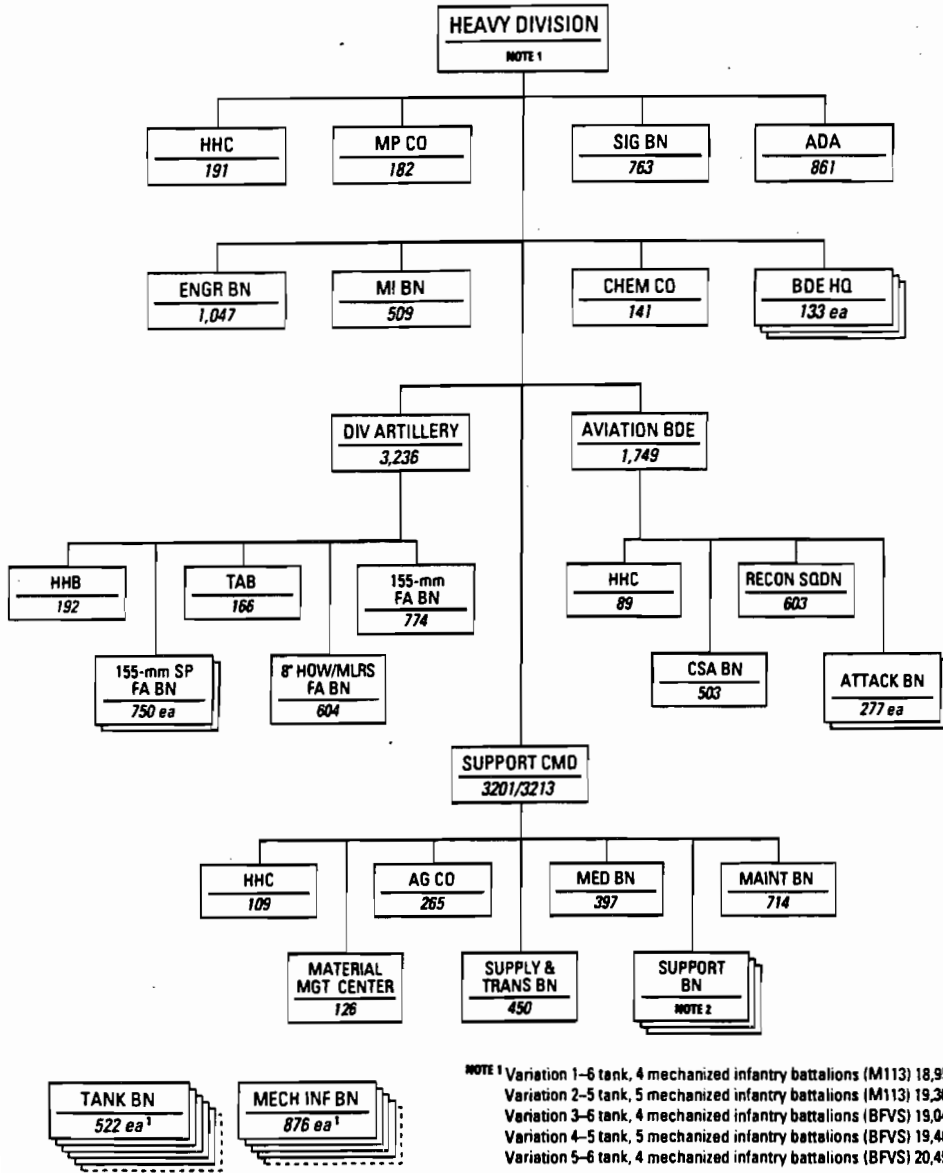

**NOTE 1** Variation 1-6 tank, 4 mechanized infantry battalions (M113) 18,954.  
 Variation 2-5 tank, 5 mechanized infantry battalions (M113) 19,302.  
 Variation 3-6 tank, 4 mechanized infantry battalions (BFVS) 19,040.  
 Variation 4-5 tank, 5 mechanized infantry battalions (BFVS) 19,407.  
 Variation 5-6 tank, 4 mechanized infantry battalions (BFVS) 20,459.

**NOTE 2** Support battalions vary in the number of armor and mechanized infantry forward support teams: 2 armor and 1 infantry, 377; 2 armor and 2 infantry, 402; and 1 armor and 2 infantry, 383.

FIGURE 9

# HIGH TECHNOLOGY TEST BED (HTTB)/HIGH TECHNOLOGY LIGHT DIVISION (HTLD)/HIGH TECHNOLOGY MOTORIZED DIVISION (HTMD) (9TH INFANTRY DIVISION), 1980–1988

**BACKGROUND AND PROPOSED UNIT MISSION:** While stationed in Europe in the mid-1970s, General Edward C. Meyer became convinced that light infantry was necessary to fight in forested and urban areas. He believed the Army needed powerful, mobile units that could be rapidly deployed throughout the world, win a victory, and then return to their home stations; in other words, the Army needed conventional light infantry to balance its conventional force structure.

In 1979, an Islamic Revolution overthrew the Shah of Iran and began a protracted hostage crisis that paralyzed the Carter administration. That same year, the Soviet Union invaded Afghanistan. Despite these threats, the United States did not deploy forces to Southwest Asia. The Army had concentrated too much attention on heavy forces and the potential Soviet threat in Central Europe. What is more, the Air Force and the Navy indicated they were unwilling to fight for appropriations to build the transportation resources to enable the Army to deploy overseas in the future. The Army Chief of Staff was faced with the possibility that the United States might need to go to war, and that the Army would not be able to deploy easily.

In June 1980, General Meyer as Army Chief of Staff, directed the establishment of a High Technology Test Bed to work with the 9th Infantry Division. The two organizations would develop, evaluate, and implement concepts and initiatives related to operations, organization, doctrine, and technology. They would enhance the division's command and control, firepower, tactical mobility, survivability, and flexibility. General Meyer wanted to create a High Technology Light Division. An October 1980 memorandum of understanding (MOU) between Forces Command (FORSCOM), Training and Doctrine Command (TRADOC), and the Development and Readiness Command (DARCOM) governed this effort.

Meyer wanted to build a force capable of deploying to Southwest Asia on C-141 aircraft (C-5s were explicitly excluded). He shared many of the senior leadership's frustrations with a procurement process that took between six and ten years to field new technologies, by which time they were obsolete. He sought to use high technology to reduce the need for a heavy division's heavy equipment. With the test bed, he departed from usual Army practice by having the 9th Infantry Division design, test, and field itself, receiving support only from concept, matériel, and training developers in TRADOC and DARCOM. He wanted to design a unit to fight primarily in the Middle East, and secondarily as a part of NATO.

General John A. Wickham, Jr., General Meyer's successor, shifted focus to create the Army of Excellence Light Division. The 9th Infantry Division became the High Technology

Motorized Division, to avoid confusion with the new Army of Excellence Light Division. By the late 1980s, force reductions cut one brigade from the division, compromising the experiment's integrity.

**PREPARATORY TRAINING:** FORSCOM commanded the 9th Infantry Division through I Corps, also based at Fort Lewis, Washington. General Meyer directed that the division commander become the HTTBT test director and further directed TRADOC to establish a test group at Fort Lewis. The chief of the test group would also serve as the deputy test director. (The test director was responsible to TRADOC for the HTTBT, and TRADOC also supplied his deputy.) TRADOC developed the outline test plans; analyzed operational and organizational concepts, doctrine, and test results; and provided periodic, independent evaluations of the test effort to the Department of the Army (DA). Meanwhile, the test director had direct access to both DA and the Army Chief of Staff. Later, the HTTBT became the Army Development and Employment Agency (ADEA), a field operating agency for the deputy chief of staff for operations. This gave it broader Army-wide concerns but lowered its visibility to the DA staff.

Initially, TRADOC believed the division would test the Infantry Division 86 design, while the division thought it had a mandate that included this design as a baseline. General Meyer gave directions supporting the division's position. TRADOC was conscious it had limited funds for testing and, therefore, wanted to exclude everything already tested. The HTLD believed it had to explore all possible improvements, even those that had not previously worked.

**UNIT FIELD TESTS:** The testing process tried to do many things. For one, it would test a radically new division configuration. At the same time, the Army Chief of Staff made plain to the test director, who was the division commander, that he did not have any obligation to test any part of the configuration that did not make sense. The Chief of Staff agreed that the division commander was incrementally converting the division into a new force.

There were numerous difficulties, especially related to funding and equipment. By May 1983, however, the basic division design neared completion and was ready for testing, evaluation, and fielding. Meanwhile, the new Army Chief of Staff, General John A. Wickham, wished to concentrate the Army's energies on other projects. That same year, 1983, he initiated the Army of Excellence study, which contained another type of light division. Therefore, the HTLD lost its high priority and resources, but its planners adapted themselves to this new environment, and the next year, General Wickham approved the HTMD design (see figure 10, page 50).

Over the next four years, the design was adjusted and tested, and by 1988, it had evolved into a unit that could fill the gap between the Army of Excellence heavy and light divisions—a unit capable of being airlifted anywhere in the world and prepared to fight enemy armored forces with great mobility and agility upon arrival.

**TEST RESULTS:** General Meyer chartered the division to design, test, and field the high-technology division itself. The test bed worked with private industry, identifying existing items that could be purchased easily. The HTLD was concept (rather than technology) driven, a departure from previous Army efforts. To test concepts, the division used surrogate equipment until private industry could provide for its needs. The division also used innovative testing methods to allow for qualitative judgments because statistical analysis could not model some aspects of the battlefield synergy. This opened the test bed to criticism by those in the Army with a vested interest in trend-line analysis and other old testing methods.

The emphasis was changed from testing highly technical equipment to developing innovative organizational and operational concepts. FORSCOM wanted the 9th Infantry Division as a currently deployable asset and maintained a steady pressure on it to sacrifice design issues on the altar of readiness. The test community usually tested equipment, not issues, and when faced with surrogate equipment, wanted to test it. When the division wanted to use an NTC rotation to test its high-technology 3d Brigade, FORSCOM refused; testing and evaluation was not part of the National Training Center (NTC) training mission.

The test focus shifted when General Wickham succeeded General Meyer. The change was accompanied by a shift away from the HTLD to the light division in the Army of Excellence. The test community opposed the 9th Infantry Division's test methodology because it tested equipment, not concepts, and wanted to continue that way even when the equipment was not available. The division also could not fill the roles assigned to it by the concept; it was hollow in fact, if not on paper. The TRADOC schools did not have the supporting doctrine or manuals for a motorized division, and there were no prepared Army Training Evaluation Program (ARTEP). As the schools shifted their focus to the Army of Excellence, they did not support the 9th Infantry Division's need for new TOEs and leadership development. Constant tension also existed with FORSCOM over the conflicts between the test function and the need to have the division perform as an integral part of the force structure. Unit readiness became an enemy of test and experimentation.

**TOE REQUIRED RESOURCES VERSUS MTOE MANNING AND EQUIPMENT:** The new division initially consisted of 13,000 personnel as opposed to 10,500 soldiers in a light division. Between 1984 and 1988, the division's organization shifted from a light configuration to a motorized one. In 1988, the motorized division had three maneuver brigades composed of nine maneuver battalions: five heavy combined arms battalions (CAB [H]), two light combined arms battalions (CAB [L]) and two light attack battalions (LAB). The air attack cavalry brigade (CB [AA]) was designed and employed as a fourth maneuver brigade. It consisted of one attack helicopter battalion, an air cavalry squadron, and a combat support aviation battalion. Division artillery consisted of three direct support battalions of 155-mm howitzers and a general support battalion of multiple launch rocket systems and 105-mm howitzers.

The CAB (H) had two antiarmor companies and a motorized infantry company. The

CAB (L) had two motorized infantry companies and an antiarmor company. Both had common headquarters and combat support companies. The LAB was configured similarly but had three companies armed with high-mobility multipurpose wheeled vehicles (HMMWV) that carried tube-launched, optically tracked, wire-guided weapons (TOW II) or the Mark 19 40-mm grenade machine gun.

**TECHNOLOGY ISSUES:** The Army was only able to field prototypes of some key pieces of the high-technology equipment. In other cases, it could not even field prototypes of certain equipment, like the fast attack vehicle (FAV), the armored gun system (AGS), the maneuver control system (MCS), and the position reporting system (PRS). These failures hamstrung the division's development.

**IMPACT ON UNIT READINESS:** Throughout the test period, there was tension between the 9th Infantry Division's role as a test bed and its role as a deployable unit. If it was to fulfill its promise as a test bed, it needed a period when it would be excused from participating in contingency operations.

**OPERATIONAL/WARTIME VALIDATION:** The division design was never made operational or tested in combat.

**INSIGHTS GAINED:** Most writers agree that the HTTBs biggest problem was its cost, compared to the benefits it offered the Army's senior leadership. They balked at one more prototype division in a resource-constrained environment. Many believed the division, as it existed in 1983–86, was too heavy to be deployed as a light division and too light to successfully engage heavy forces. Part of the problem was that surrogate equipment became standard during its interim phase. As the 9th Infantry Division was integrated into different war plans, it was clear it did not fit the needs of the warfighting commanders in chief (CINCs). The HTLD was designed to fight in the deserts of Southwest Asia. Between 1983 and 1986, that area of the world receded as a major concern. Further, in 1987, Congress cut the military budget, which meant force reductions. The division lost an active component brigade. It was replaced with a heavy reserve roundout brigade. By then, it was clear the experiment had reached a dead end. In December 1988, one of its remaining active brigades was converted from a combined arms brigade to a heavy brigade.

The Army did gain insights from the HTTB and the 9th Infantry Division experiment. New command post concepts showed the Army new command and control possibilities. The division pioneered the use of pallet loading to shorten time in transit. It clearly demonstrated the need for a positional navigation system. In addition, the 9th Infantry Division worked out and demonstrated the tenets of AirLand Battle, which had a clear effect on the Army of Excellence.

Critical pieces of equipment needed to realize the division concept were never available. The FAVs it wanted were neither authorized nor funded by Congress, and the AGS was never successfully developed. The substitutes, moreover, did not provide the capabilities envisioned

by the original concepts.

The testing methodology proved itself to some, but not to others. Optimists were excited by the effort's promise, while pessimists concentrated on the unit's deficiencies as a deployable asset. In addition, throughout the test period, there was a tension between the 9th Infantry Division's role as a test bed and its role as a deployable unit. If it was to fulfill its promise as a test bed, it needed a period when it would be excused from participating in contingency operations.

The HTLD was an attempt to create a solution tailored to fit a particular niche in national defense needs. It took shape when the major threat was the Soviet Union. It was hard to convince an Army interested in a unit that was larger, bigger, and heavier that it needed a unit that was smaller, lighter, and faster.

Since the HTLD was eclipsed by the light division, American industry gained the capability to produce tailored products. Today, the Army supply system is not as dependent on identical equipment because the logistics system can use information technology to identify requirements and ship the needed parts to the right units.

The HTTB violated every tenet for successful experimentation, but its greatest failing was its inability to establish an Army-wide consensus to enable it to succeed. Because the effort was personally tied to an Army Chief of Staff, the effort collapsed when General Meyer retired. Because of its innovative testing methodology, the HTTB concept was seen as invalidated. These failures doomed the test bed.



# MOTORIZED DIVISION (HTMD) 1984

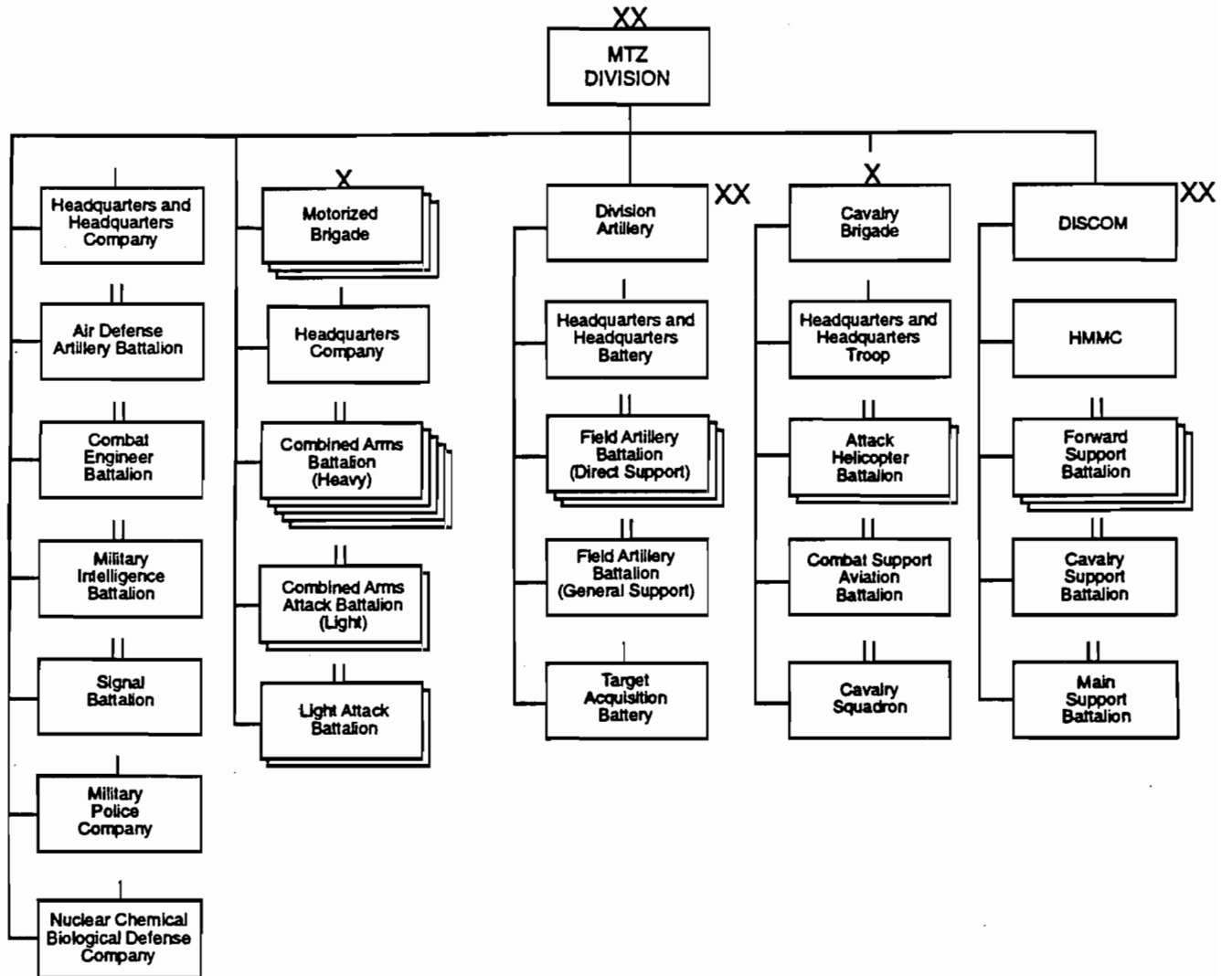

FIGURE 10

## 7TH INFANTRY DIVISION (LIGHT), 1983–1986

**BACKGROUND AND PROPOSED UNIT MISSION:** By 1983, the Army was again concerned about force-structure. Global commitments meant preparing for the possibility of a mid- to high-intensity threat from the Soviet Union, as well as preparing for contingency operations that would involve low-intensity conflict or terrorism. However, the nation's ability to project its military power was limited by airlift and sealift resources and by high unit deployment profiles (most units needed many air and sea sorties to completely deploy all their soldiers and equipment). In short, it took too long to get the available forces to the potential battlefield.

Another of the governing forces behind the Army of Excellence program was the Army's hollowness. It was unable to staff units at full strength. Congressionally imposed manpower ceilings meant that division and nondivisional units divided limited manpower resources. The Army needed a division to perform contingency missions at short notice. But the light division was probably the most controversial division design since the Pentomic division. Some of the Army's senior commanders questioned the need for a light division in Korea and Europe, while others argued that no corps-level support base had been created to support the proposed, austere manned light division.

In June 1983, General John A. Wickham, Jr., became Army Chief of Staff. He ordered Training and Doctrine command (TRADOC) to design a 10,000-men light infantry division (LID) deployable in 500 C-141 sorties (see figure 11, page 54). He conceived this division as the centerpiece of a complete redesign of the force structure called the Army of Excellence. The Combined Arms Center briefed the new force design to the Army Commanders' Conference in October 1983. On 18 January 1984, President Reagan approved the Army's new light infantry division. On 1 February 1984, Secretary of the Army John O. Marsh announced the conversion of the 7th Infantry Division at Fort Ord, California, into a light infantry division. Before its conversion, the 7th Infantry Division was a heavy infantry division, with a strength of 18,300 officers and men, including its reserve component roundout brigade.

**PREPARATORY TRAINING:** TRADOC and FORSCOM conducted the division's joint certification from January 1985 through 1986 at Fort Hunter Liggett, California. According to a TRADOC and Forces command (FORSCOM) MOU, the Commander, I Corps, served as the certification director, and the division's commander was his deputy. The division used Exercise Celtic Cross IV for final certification. TRADOC schools and centers developed manuals, ARTEPs, and MTOEs for the new organization.

General Wickham, meanwhile, directed the LID's design, certification, and fielding. He used the Army Commanders' Conferences to build a consensus among the senior leadership on concept and force design. He directed TRADOC to design the LID, which meant that command would also develop leadership training, force design, and documentation as needed for the division. General Wickham established a LID General Officer Steering Committee

for the division. General Wickham established a LID General Officer Steering Committee (GOSC) to review the effort's progress and to keep attention focused on the desired result. The LID GOSC included representatives from the Army major commands, the Military Personnel Center, and the Concepts Analysis Agency. A general officer from the Deputy Chief of Staff for Operations office chaired the committee. Major General Leonard Wishart, Deputy Commander, Combined Arms Center for Combat Developments (CAC-CD), and his staff traveled to all the CINCs and senior Army commanders to brief them on the LID design. FORSCOM had jurisdiction over the 7th Infantry Division and played a critical role in the certification process.

CAC, with its branch proponents, developed the force structure before the concept's employment. Others at CAC, besides force designers, also worked on the concept. Because the branch schools and centers participated in the design effort and in preparing leader development and unit training materials, they were committed to its success.

**UNIT FIELD TESTS:** Unit certification began in January 1985 and lasted through 1986. Certification took place primarily at Fort Hunter Liggett, California. A memorandum of agreement (MOA) between TRADOC and FORSCOM designated the I Corps commander as certification director and the commander of the division as his deputy. The division used the Celtic Cross IV exercise for final certification. TRADOC centers and schools developed manuals, ARTEPs, and MTOEs for the new organization.

**TEST RESULTS:** In certifying and fielding the LID, the Army relied on already-available technology. Though there were problems with some of the equipment, this approach allowed the division to be fielded in a relatively short time.

The LID proceeded quickly from idea to fielded unit. Its existence served as part of NATO's deterrent defense and provided a deployable contingency force for use outside Europe. After certification, the division consisted of 10,483 officers and men and could deploy in 550 C-141 sorties.

**TOE REQUIRED RESOURCES VERSUS MTOE MANNING AND EQUIPMENT:** Planners at Combined Arms Combat Development Agency (CACDA) created an organization specifically designed to carry out contingency missions that did not involve heavy combat. To this end, the division was given only enough support systems to operate in a low-intensity environment for forty-eight hours without external support. Designers reduced logistics, fire support, antitank, and survivability assets. Whenever possible, they replaced organic capabilities with cadre personnel organized to accept corps augmentation quickly. The final design (10,500 soldiers) was an extremely lean, foot-mobile division.

**TECHNOLOGY ISSUES:** In certifying and fielding the LID, the Army relied on already available technology. Though there were minor problems with the number and placement of some of the radio equipment, this approach allowed the division to be fielded in

**IMPACT ON UNIT READINESS:** The division was converted from a heavy division to a light division, losing 45 per cent of its personnel strength. It was reequipped based on alternatives that capitalized on the high-technology light division (HTLD) capabilities whenever possible. The new configuration was characterized by a high combat to combat service support ratio, common organizational vehicles and equipment, as well as an ability to receive and integrate augmentation forces and support rapidly. This necessitated retraining the division and had an adverse impact on readiness.

**OPERATIONAL/WARTIME VALIDATION:** The LID was a controversial design. Units were fielded within a year after the studies were completed. It gave the Army a viable force while expanding its operational possibilities. It was used in Panama during Operation Just Cause and in Saudi Arabia-Kuwait for the Gulf War, Operation Desert Shield/Desert Storm.

**INSIGHTS GAINED:** Different sectors of the Army criticized aspects of the LID. Some noted it was too light to face heavy forces, others that it lacked tactical mobility, while still others said it emphasized combat power at the expense of support units. All the criticism was not consistent. However, there was an ongoing concern about the LID's relationship with the Reserve forces. Several members of the Army's senior leadership questioned whether the roundout brigades that had been part of infantry divisions could maintain the required combat readiness to be part of the LID. This division had to be deployable as part of a contingency force, which meant any Reserve formation associated with it had to be equally deployable. In light of this, the Army decided to replace the roundout units with active units.

When he created the Light Infantry Division, General Wickham established TRADOC as the "Architect of the Future" and charged it to design the change and market it to the Army. The effort relied on a common leadership culture and a widespread concern about hollowness and deployability. The Army Chief of Staff established TRADOC (CAC in particular) as the proponent for change. CAC then served as the honest broker between the branch proponents in the effort to establish a workable and acceptable force structure. General Wickham worked to build a consensus and involved other agencies in this process, including the Army Commanders' Conference, the LID GOSC, TRADOC, and FORSCOM. The speed with which fielding occurred ensured leadership continuity. Because several critical actors in the 7th Infantry Division (Light) force design and fielding process rose to senior leadership positions in the Army, they, too, provided critical leadership continuity. The Army of Excellence and the Light Infantry Division efforts had the Army Chief of Staff's active and visible support. The LID certification process was also credible to the Army as a whole. The force structure and equipment changes that came from certification gave the process even greater credibility.

In the last years of the Cold War, the change to a Light Infantry Division was a success. It gave the Army a contingency capability, while it added to the deterrence of conflict in Europe.

Light Division, 1 October 1985

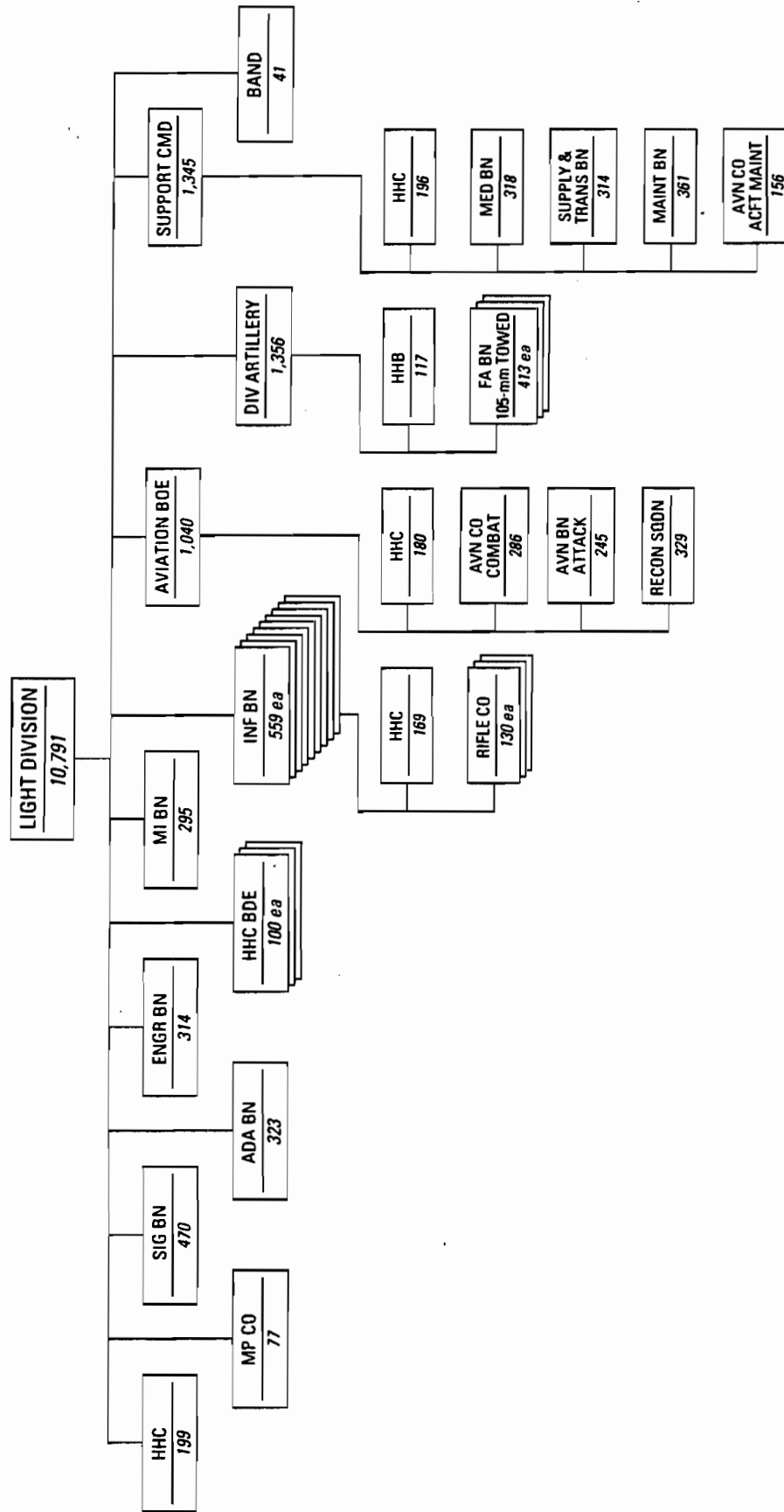

FIGURE 11

# FORCE XXI/EXFOR/EXPERIMENTAL DIVISION, 1993–1997

**BACKGROUND AND PROPOSED UNIT MISSION:** After the victory in the Gulf War and the collapse of the Soviet empire, the Army temporarily stopped exploring doctrine and force design changes. Army Chief of Staff, General Carl E. Vuono, concluded that there was no need to change for the sake of change. However, the focus on various combatants without superpower status and the diverse missions to which ground forces were committed combined with the extraordinary growth of information technology to create a different world for the post-Cold War Army and its Chief of Staff, General Gordon R. Sullivan. These factors compelled the Army to reexamine its doctrine and force design.

On 22 January 1993, General Sullivan endorsed the concept of “digitizing” the divisions, i.e., linking combat elements with sophisticated computers, enabling units to share situational awareness, and allowing commanders to make rapid, accurate tactical decisions. Eventually, General Sullivan became convinced that the shape of the new force could not be resolved by debate. General Frederick M. Franks, Jr., Training and Doctrine Command (TRADOC) Commander, was convinced earlier and persuaded Sullivan that the path to change lay in experimentation. By 1994, most of the Army’s senior leadership accepted this idea.

General Sullivan formally initiated FORCE XXI, a term describing this redesign process, on 8 March 1994. TRADOC and its new commander, General William W. Hartzog, were an important part of the process (see figure 12, page 60). The effort would be centered on redesigning the heavy division. After a briefing from planners, General Hartzog recommended to General Dennis J. Reimer, General Sullivan’s successor as the Army Chief of Staff, that a hybrid heavy division design was the best option for further study and experimentation.

**PREPARATORY TRAINING:** One of the Experimental Force’s (EXFOR) most difficult tasks was synchronizing the training plan, the force modernization plan, the appliqué (a prototype set of hardware and software providing common computer links in a combat brigade) plan, and the experimental plan. Training could not begin until the force modernization and appliqué plans were completed. The experiment could not begin until the unit was trained. The compressed schedule (force modernization and appliqué, March 1995 to 31 May 1996, training, 1 June 1996 to February 1997) left little room for missteps.

Eventually, members of the division would say, “We don’t know what we don’t know.” Two critical areas dealt with were planning for and implementing a division redesign for the experimenting, developing, and implementing of new C<sup>2</sup> structures for combat. Uncertainty remained high, but the division trudged toward the experiment.

For the first seven months of 1996, the 4ID’s 1st Brigade was transformed and manipulated by various experts, specialists, contractors, and consultants. Even when ready for training, the

brigade was still closely scrutinized by the Army's leadership and subject to stresses placed on no other brigade. Two complex processes occurred: (1) building fundamental tactical skills and (2) integrating the immature Tactical Internet (TI) into combat training operations. The TI, available in August 1996, showed great promise but provided little hope to a commander who would use it in combat training nine months later. The technology was fragile, leaving the commander to integrate it into his tactics and his soldiers to exploit its every advantage and accommodate its disadvantages.

The unit also had to train for a National Training Center (NTC) rotation. Building proficient tactical units is difficult when junior leaders are new and inexperienced. The U.S. Army Test and Evaluation Command (OPTEC) reported that three-quarters of the brigade's platoon leaders and sergeants were new to their positions. Guided only by experienced platoon sergeants and company commanders, they would learn tactical skills but without external criticism. It would be difficult for everyone if the new leaders had to master combat fundamentals and digital equipment simultaneously. The latter was unfamiliar to everyone, and contractors were still working on the TI. In addition, there were outside experts taking notes, and often, general officers or distinguished civilians were watching every move.

Because basic tactical training and learning the TI competed for time, a training schedule was developed to isolate them. Ideally, units through battalion level would train in the field to learn tactical fundamentals. Then, they would receive digital equipment and conduct individual new equipment training (NET); take the equipment to the field and train as platoons, companies, and a task force (TF), overlaying the digital systems onto a trained unit; and, finally, execute the Advanced Warfighting Exercise (AWE).

The soldiers received the digital equipment and conducted NET before receiving fundamental tactical training. Meanwhile, the brigade staff designed a plan to integrate the equipment and move to the field to learn how to fight. The plan incorrectly assumed training would begin by 1 June 1996.

The battle drills focused on making the digital equipment work, and platoon training results were mixed. The equipment's potential was obvious, but there was a great difference between potential and actual performance. The immaturity of the new technology affected all areas. A platoon had marginal ability to conduct digital operations, and technologically, the TI made little progress when company training began. The percentage of tactical vehicles displayed on appliqué computer screens did not increase. However, this low percentage filled company screens with friendly icons, making it appear that the TI improved greatly. However, even lackluster TI performance was useful to a higher headquarters. As the technology improved, the issue of fundamental tactical skills came to the fore. Fragile technology was issued to uncertain soldiers. As the soldiers gained experience and the technicians improved the systems, a standard of "just-good-enough" developed.

The brigade commander and staff understood a tactical environment that reflected Clausewitz's description of a war in which "three-quarters of the factors on which action . . . is based are wrapped in a fog of greater or lesser uncertainty. In such an environment, a

sensitive and discriminating judgment is called for, a skilled intelligence to scent out the truth." Thus, the men were trained to expect hints of truth and to build their estimates on them. Although the TI reported intermittently or incompletely, it gave them more concrete facts than they had previously imagined receiving.

**UNIT FIELD TESTS:** The Army planned to test the design in a series of AWEs. The 2 AD, later redesignated the 4ID at Fort Hood, was designated the EXFOR. The test's culmination would be a brigade-sized field test at the NTC and a division AWE at Fort Hood. To help coordinate implementation and track progress on mastering the technological challenges, an Experimental Force Coordination Cell (ECC) was established at Fort Hood.

**TEST RESULTS:** OPTEC implied that the experiment could have yielded more concrete insights if the unit had been better prepared in both combat fundamentals and fully functioning digitization and then trained in how to exploit the combination. Early in the process, time was scheduled to train on combat fundamentals. This was dropped when it became obvious that the technological challenges of a TI would not be met on time. Additionally, waiting for fully functioning digitization before proceeding with the experiment would have meant a delay until the next century. The concepts espoused were sound projections of technological capabilities, but expecting the technical architecture to be built in less than a year may have been expecting too much. That any system was produced, no matter how fragile, was astounding.

The OPTEC observation correctly identified the two elements of the TF XXI AWE that constrained its success. The technologists produced the matériel as quickly as possible. Given the circumstances, it is hard to imagine the appliqué, or the TI, could have been more mature than it was in March 1997. It is fair to ask if more time could have been found, more time to train the brigade in fundamental combat skills.

If the technology matured as rapidly as possible, there were two other ways to provide more training time. First, delay the AWE. Three facts made this unattractive: (1) all the interested constituencies—Congress, retired military officers, senior military leaders, and allies—closely followed the experiment's progress since it began. They were patient, but their patience was limited; (2) the brigade commander and his staff believed the troops could not maintain the hectic pace beyond March 1997; and (3) General Reimer wanted to use the TF XXI AWE results in his 1997 Program Objective Memorandum (POM) submission. Waiting until March compressed this schedule, but waiting longer would have made it impossible.

The only other way to gain more training time would have been to allow piecemeal training, i.e., some elements would train, while the equipment of others was modified. Coordinating a plan like this was beyond the authority and capability of the brigade commander and his staff. It would have required platoon and company training with pre-positioned tactical vehicles reserved solely for the EXFOR. Fort Hood's other division, the 1st Cavalry Division, would have been excluded from these training areas, degrading its own readiness. The III Corps commander, whose primary responsibility was the readiness of his



corps and its divisions, would have vigorously protested. Probably, the unity of effort, characterized by the TRADOC and Forces Command (FORSCOM) commanders' close coordination through the ECC would have been strained. This option was not possible in the confusing, coordinated command structure.

The TF XXI AWE's qualified success does not detract from its achievements. Without a highly visible, large-scale experiment scheduled for March 1997, a TI, however fragile and immature, would not have been created in 1996. If the experiment had been conducted at Fort Hood instead of the NTC, it would have been viewed as a formality, reaffirming the Army senior leadership's vision. If the experiment had not proceeded, debate about digitization's effectiveness and its impact would have remained abstract. The analytical models supporting Force XXI and the debate over digitization were made better because of the test.

**TOE REQUIRED RESOURCES VERSUS MTOE MANNING AND EQUIPMENT:** The FORCE XXI interim division design was slightly smaller than the Army of Excellence division, totaling 15,820 people. Modifications included increased fire support to shape battle space, expanded reconnaissance and intelligence capabilities, greater consolidation of logistics support functions, and additional infantry.

**TECHNOLOGY ISSUES:** Technology issues were rampant. They included the creation of appliqué systems and a tactical internet, but these were only two of the more than seventy-five systems that were tested. All of the equipment was fragile and in the prototype stage. The problems with this new, untested equipment and the concomitant reduction in training time led to the relatively lackluster results in the TF XXI AWE at the NTC.

**IMPACT ON UNIT READINESS:** Designating the 2AD, reflagged as the 4ID, as a test division had an adverse impact on its combat readiness. Although only the 1st Brigade was involved in the NTC AWE, the division's other units were involved in helping the brigade prepare for it. The problems associated with integrating experimental equipment into the brigade and training new and inexperienced soldiers and leaders highlighted the problems inherent in all experimental units. In addition, if III Corps' training resources were wholly devoted to the EXFOR, the readiness of the other division at Fort Hood, the 1st Cavalry Division, would have been degraded. The III Corps commander would have dissented vigorously.

**OPERATIONAL/WARTIME VALIDATION:** The unit has not yet been used in actual operations.

**INSIGHTS GAINED:** The EXFOR affected the Army's culture by changing the terms of the digitization debate. Almost every part of the experiment challenged principles of Cold War Army culture. Experimentation did not answer all the questions, but it showed the practicality of some of the ideas. It also raised unexpected questions and insights.

In Division XXI, brigades can move farther apart because they can see each other

“virtually.” An enemy attempting to exploit a gap between them can be discovered and destroyed in many ways. This was validated in the division AWE. However, dispersion’s negative aspects were also clearly defined.

The speed of ground movement is an important limitation. The division could detect opportunity and crisis early, but if the commander decided to integrate ground forces into his response, he was limited by their movement time. In many cases, the commander did not maintain a ground reserve. Given the distance it must travel to exploit a situation, such a reserve would have had negligible influence. Additionally, even with the increased logistical knowledge, the supplies still had to be delivered, and they, too, were limited by the speed of ground transportation. These considerations limit the commander’s freedom of action. As the Army considers the 21st century force, it must either increase ground speed or permanently accept this limitation.

In dispersing maneuver forces, Force XXI operations increased the value of its intelligence gathering and fire assets. These high-value assets (HVAs) were vulnerable to ground attack by small and light forces. With maneuver forces farther away, HVAs found themselves under constant threat of enemy attack. This forced brigade commanders to use combat forces in a security role. As the nature of the division becomes better defined, this tension between HVA, security, and combat maneuver forces will be an important issue.

# FORCE XXI (1995)

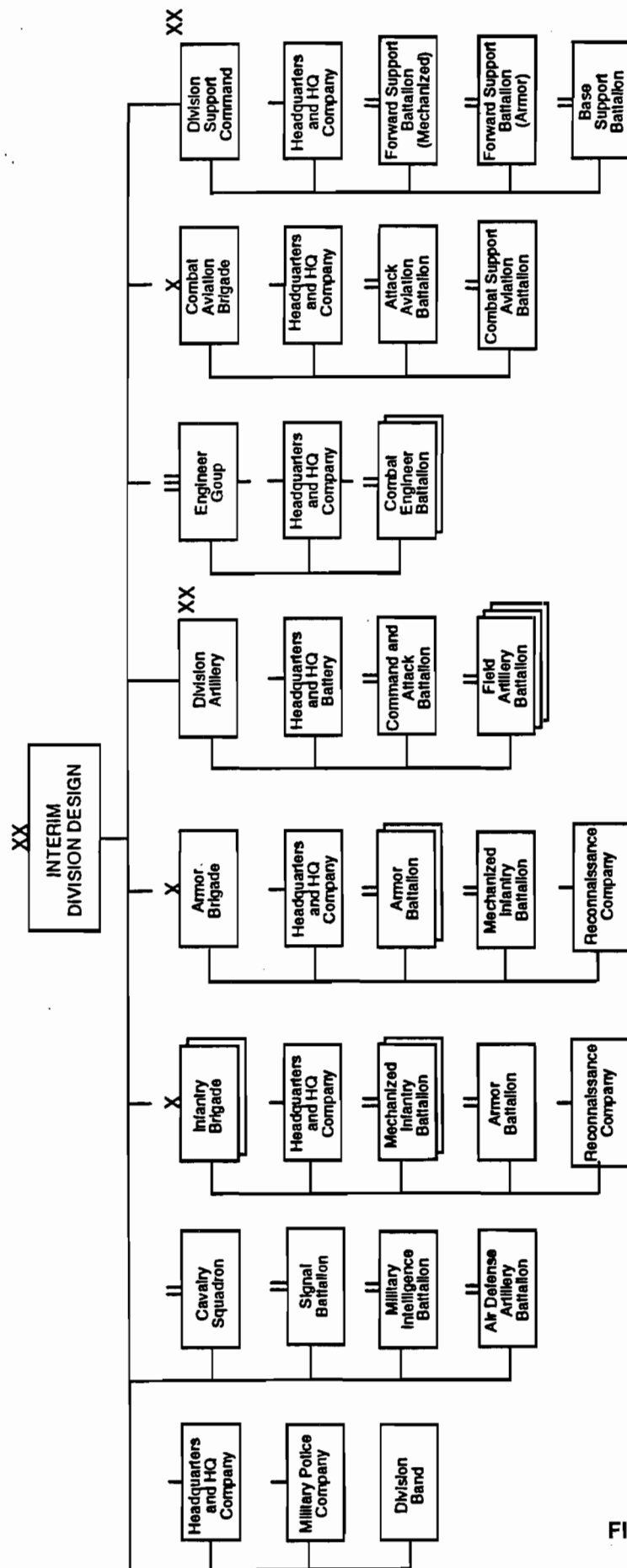

FIGURE 12

# CONCLUSIONS

Over the past sixty years, the Army has undertaken a major reorganization of its division structure on twelve separate occasions. Each reorganization was unique. Objectives, methods, and degrees of success varied from one to another. And yet, some common threads can be discerned. The following conclusions are framed in terms of the nine issues discussed under each of the preceding case studies.

**PROPOSED UNIT MISSION:** Each of the reorganizations studied was undertaken to address a specific need perceived by the Army. These reorganization objectives can be roughly grouped as follows:

- Reorganization to meet a specific threat.
- Reorganization to utilize or accommodate new technology.
- Reorganization to accommodate austerity in one or more areas.

These studies suggest that the most successful reorganization is the one that is designed to meet a specific opponent on a known battlefield. The ROAD and Division 86 initiatives, which fall under this heading, had fewer unknowns to confront than did many of the others. They also enjoyed a wider level of acceptance within the Army than most of the other reorganizations.

Technology-driven reorganizations, such as the 11th Air Assault Division and Force XXI/EXFOR, are inherently more speculative in nature as regards enemy and theater. They are also likely to lie outside of the Army's institutional "comfort zone."

Reorganizations that are intended to address austerity, be it shrinking manpower pools or lack of strategic transport, run the grave risk of creating a structure that is deployable but not "fightable." Since 1943, for example, the problems of inadequate combat power and sustainability have plagued every effort to design a "light" division, even when the reorganization procedures themselves went smoothly.

**PREPARATORY TRAINING:** In testing a new organizational concept, it is essential that the concept and not the inherent fitness of the test unit functions as the factor that determines the test outcome.

Two alternatives exist for selecting the test unit:

- Convert an existing formation to the new structure.
- Assemble a new formation for test purposes.

The preceding case studies suggest that the best course of action is to utilize an existing formation that is already proficient in fundamental skills. This practice is the more efficient in terms of time, has less impact upon the rest of the Army, and helps assure that the results of

the test are valid. The smooth conversion of the 7th Infantry Division from “heavy” to “light” configuration is an example.

If a new formation is to be assembled for test purposes, extra time should be allowed for the test unit to train, either before the test or concurrently with the test process. The 11th Air Assault Division and the EXFOR both provide examples of the difficulties that will be encountered if such time is not provided. The World War II armored division and the ROAD reorganizations allowed for systematic, progressive training within the test units.

**UNIT FIELD TESTS:** The actual conduct of field tests has taken several different forms. Variations found within the case studies include:

- Test unit assembled, trained, and tested concurrently.
- New concepts and new technologies tested concurrently.
- Tests planned and administered by recognized proponent agencies.
- Test formations planned and administered by its own test program.

In considering the issues to be tested, it is clear that an essential aspect of a successful test program is to control the number of variables that may influence the outcome. Although a hastily created formation, the 11th Air Assault Division, utilized carefully controlled maneuvers designed to address specific issues. The World War II armored division and the HTTB provide negative examples: surrogate equipment, experimental doctrine, and leadership all affected test outcomes simultaneously, obscuring the lessons to be derived.

As to the actual administration of the testing program, the HTTB again serves as a negative example. The test unit formulated and conducted its own test program, leading inevitably to questions of credibility. In contrast, EXFOR utilized established test agencies, such as NTC, lending instant credibility to test results.

**TEST RESULTS:** The testing of new organizational concepts produced three different results in the case studies examined above:

- The reorganization needed fine-tuning.
- The reorganization needed major modifications.
- The new concept showed potential not yet realized.

The ROAD reorganization is a good example of the “fine-tuning” result. In this case, however, it should be understood that the “reorganization” was essentially a return to an earlier structure. The ROAD division was the lineal descendent of the 1943 armored division that the Army’s senior leadership knew from their service in World War II.

The Pentomic division serves as an example of a test that indicated a need for major

modifications. It displayed numerous deficiencies that were never adequately addressed, and the concept ultimately failed. By contrast, the 11th Air Assault Division survived, despite the fact that its deficiencies could not be corrected immediately.

EXFOR exemplifies the third possible outcome. Although test results were superficially unimpressive, Army leaders recognized that the technology involved was still in its infancy and that the experiment was far from over.

**TOE REQUIRED RESOURCES VERSUS MTOE MANNING AND EQUIPMENT:** Rarely, if ever, is the Army able to resource fully a new organizational concept. Two alternative situations have suggested themselves:

- Tests indicated the need for more assets.
- The test organization were intentionally “lean,” actually reducing the assets required.

Every case study except one involved a call for more assets in the reorganized unit. In times of Army growth, not surprisingly, the new requirements can often be met (ROAD division). More commonly, the provision of new assets is incremental and prolonged, as in the case of Division 86. All too often, the Army proceeds with reorganization “on the cheap,” expecting units to do more with less. TRICAP suffered a different fate. The post-Vietnam drawdown led to the abandonment of the reorganization and the elimination of the test unit. The division reorganization of 1947–48 was the least well-resourced of them all.

The triangular division and the 7th Infantry Division underwent an intentionally “lean” reorganization. History, however, suggests a cautionary note. Attempts to streamline and lighten the divisional structure usually involve the shifting of assets to other echelons and in the creation of a division that needs to be reinforced again before it can fight effectively.

**TECHNOLOGY ISSUES:** Technology influences reorganization in two ways:

- Technology pushes reorganization.
- Reorganization creates a demand for new technology.

The Pentomic Division was a hastily conceived initiative pushed by new technology (atomic weaponry) but without a clear doctrine for its battlefield employment. EXFOR was also pushed by technology, but in this case the Army refrained from embarking upon wholesale immediate reorganization because the technology itself was still evolving.

The advent of airmobility illustrates both points. Obviously, technology triggered the whole airmobility issue. In addition, the 11th Air Assault Division experiment also spelled out the need for new technology and provided a sound basis for its eventual acquisition.

The triangular division, the World War II armored division, and the Division 86 experiences optimized the technology factor. This reorganization was founded upon a clearly perceived doctrine that induced the development and acquisition of new technology. This example also reflects the fact that technologically induced change is usually incremental, not revolutionary.

**IMPACT ON UNIT READINESS:** Obviously, the act of reorganization temporarily reduces a formation's readiness to go to war. Less obvious is the impact upon the Army's overall readiness when a formation is designated as a test unit. Two alternatives exist:

- The reorganizing formation is relieved of any deployment responsibility.
- The reorganizing formation is considered to be deployable.

To put it succinctly, reorganization and deployability are incompatible. This is particularly true for a test formation, such as the 1st Cavalry Division, which struggled to stay deployable throughout the TRICAP test. The worst-case example in this regard is the Pentomic Division, which may well have been nonviable, even after its adoption.

**VALIDATION IN BATTLE:** Typically, the U.S. Army has time to test and modify division structures before committing them to combat. In World War II, several years elapsed between the outbreak of hostilities and the deployment of divisions in the theaters of operations. The experience of other belligerents shaped the development of doctrine and force structure. Similarly, lessons learned from the on-going Vietnam conflict helped guide the 11th Air Assault Division initiative. Thus, new divisional organizations have benefited from combat experience without having to endure the combat.

No American division organization has ever blatantly failed in combat, but all have undergone modifications after commitment to battle. These modifications generally involve adding rather than removing assets. This pattern suggests that designers of division structures tend to underestimate the demands of combat. Battle punishes "lean" divisions that are too austere.

**INSIGHTS GAINED:** In conclusion, the following insights can be gleaned from the case studies examined:

- Reorganization imposed from above, in the absence of Army-wide support, will fail with the departure of its author and proponent.
- Turf battles among agencies and contests between "progressive" and "reactionary" factions are destructive and long-lived.
- The most successful reorganizations involve consensus building and co-opting of senior leadership early in the reorganization process.
- The Army benefits from the existence of permanent testing agencies and facilities, as

opposed to reinventing the wheel with each reorganization.

The HTTB, initiated by one Chief of Staff of the Army who chose not to work through established channels, never won acceptance in the Army at large. When that Chief retired, there was no proponent to continue the effort.

Under different circumstances, questions over proponency can escalate into institutionally divisive turf battles. The development of an armored division languished for a decade because no combat arm claimed proponency. The 11th Air Assault Division experiment, as part of a larger debate over airmobility, divided the Army into warring camps and invoked the hostility of the Air Force. While such contention may at times be the inevitable price of progress, institutional feuds clearly should be avoided whenever possible.

It is obviously preferable to generate agreement over fundamental issues before reorganization is attempted. An excellent example of consensus building is that of the 7th Infantry Division's transition to "light" configuration. Another is the ROAD division. In both, the Army as a whole recognized the need for change, and many agencies participated in the conceptualization and testing processes.

Finally, it can be noted that every reorganization initiative since 1975, with one exception, has met with success (if one considers the DRS program to be subsumed under Division 86). The exception is HTTB. It is no coincidence that HTTB is the one initiative that was undertaken outside of the framework for creating doctrine that was established after the Vietnam War. TRADOC, NTC, and other existing agencies all have obvious and important roles to play in future reorganization efforts.

Three recommendations can be derived from this historical examination of Army reorganization efforts. First, have a clear and valid reason, based upon doctrine and battlefield realities, for reorganizing. Second, give an explicit sense of direction to the testing agency and to the Army at large so that the goal of reorganization is commonly understood. Third, set specific concrete goals for the testing agencies, and assure that the evaluation process is a valid test of the reorganization concept, not a rubber stamp. Following these procedures will help assure that the reorganization process succeeds both institutionally and on the battlefields of the future.