



INSTITUTE FOR DEFENSE ANALYSES

**Improving Integration of Department
of Defense Processes for Capabilities
Development Planning**

Dr. John T. Hanley, Jr., Task Leader
Mr. Michael F. Fitzsimmons
Mr. James H. Kurtz
Mr. Lance M. Roark
Mr. Vincent P. Roske, Jr.
Mr. Daniel L. Cuda

September 2006
Approved for public release;
distribution unlimited.
IDA Paper P-4154
Log: H 06-001346

This work was conducted under contracts DASW01 04 C 0003 and W74V8H 05 C 0042, Task CA-8-2621, for the Director, Force Structure and Resources (J-8), The Joint Staff. The publication of this IDA document does not indicate endorsement by the Department of Defense, nor should the contents be construed as reflecting the official position of that Agency.

© 2006, Institute for Defense Analyses, 4850 Mark Center Drive, Alexandria, Virginia 22311-1882 • (703) 845-2000.

This material may be reproduced by or for the U.S. Government pursuant to the copyright license under the clause at DFARS 252.227-7013 (NOV 95)

INSTITUTE FOR DEFENSE ANALYSES

IDA Paper P-4154

**Improving Integration of Department
of Defense Processes for Capabilities
Development Planning**

Dr. John T. Hanley, Jr., Task Leader
Mr. Michael F. Fitzsimmons
Mr. James H. Kurtz
Mr. Lance M. Roark
Mr. Vincent P. Roske, Jr.
Mr. Daniel L. Cuda

Preface

This paper was prepared for the Director for Force Structure, Resources, and Assessment (J-8) under the task order “Studies and Analyses for Implementing Capabilities-Based Planning” The study objective was to identify potential areas for improvement in management processes that would increase the effectiveness of the overall Department of Defense effort to implement capabilities-based planning, and in particular to facilitate J-8’s efforts to support the Chairman of the Joint Chiefs of Staff in the responsibilities assigned to him by the Secretary of Defense and by Title 10, United States Code.

The study team gratefully acknowledges the helpful advice and assistance received during the course of our work by LTC Boyd Bankston, USA, and LTC Todd E. Key, USA, both of the Joint Capabilities Division in J-8, and COL Steve Lanza, USA, their division chief.

The authors also greatly appreciate the helpful comments and suggestions received from our colleagues Dr. Michael Fischerkeller, Mr. Gene Porter, and Mr. Jim Wilson during their review of the paper.

This paper does not necessarily reflect the views of Institute for Defense Analyses or the study sponsor. Its intent is to stimulate ideas, discussion, and, ultimately, to help accelerate change processes in the Department of Defense.

This page intentionally blank.

Table of Contents

<u>Title</u>	<u>Page</u>
Executive Summary	ES-1
Chapter 1: Study Purpose and Background	1-1
Chapter 2: Analytic Framework for Assessing Capabilities Development Planning Activities	2-1
Chapter 3: Alignment of Planning Processes and Key Decisions	3-1
Chapter 4: Improving Processes to Support Decision-Making	4-1
Chapter 5: A Potential Integrated Capabilities Development Planning Process Flow	5-1
Chapter 6: Conclusion – The Road Ahead	6-1
Appendix A: Planning, Programming, Budgeting, and Execution	A-1
Appendix B: Strategic and Planning Guidance	B-1
Appendix C: Analytic Agenda	C-1
Appendix D: The Functional Capability Board Process and the Joint Capabilities Integration and Development System (JCIDS)	D-1
Appendix E: Joint Concept Development	E-1
Appendix F: Acquisition	F-1
Appendix G: Statutory Requirements of the Secretary and the Chairman	G-1
Appendix H: Options Summary	H-1
Appendix I: Acronym Glossary	I-1

This page intentionally blank.

Executive Summary

The study presented in this report was sponsored by the Joint Staff's Director for Force Structure, Resources, and Assessment (J-8) and was conducted by a cross-divisional team of analysts from the Institute for Defense Analyses during the first half of 2006. The goal was to produce an analytic framework and substantive foundation for creation of a Chairman of the Joint Chiefs of Staff Instruction on the implementation of "capabilities-based planning" (CBP) processes in the Department of Defense (DoD). In the last few years, DoD has taken many positive steps toward implementing the vision of rational, agile, joint planning that has been advanced under the banner of CBP. However, this study was initiated on the premise that processes supporting CBP are not fully integrated with one another today and are not fully aligned with the congressional budget cycle that drives resourcing decisions in the Department.

In attempting to identify the most important of the remaining challenges in integrating DoD planning processes, this study focused on those processes that aim to define, design, and develop capabilities for the future joint force (referred to here as "capabilities development planning"). It does not address in detail those processes focused on the employment of existing capabilities (referred to here as "force employment planning"). The report also gives particular attention to those processes by which the Chairman of the Joint Chiefs of Staff fulfills his statutory roles.

Throughout the paper a variety of options are presented for improving the integration of capabilities development planning processes. The general themes reflected in these options can be summarized as follows:

- Decision support processes should be designed and scheduled to inform the development of strategic guidance, not only react to it. In particular, the Chairman would greatly benefit from a more formal mechanism for generating and delivering integrated advice to the Secretary as input to the Strategic Planning Guidance document.
- Creating a formal mechanism within the regular budget cycle for consideration of major capability trade-offs is absolutely essential to rationally link strategic guidance to programmatic guidance.
- Greater joint analytic and management attention should be given to holistic, strategic-level assessments of the entire force against the entire set of missions required of the force. Functional Capability Boards and unified combatant commands (COCOMs) are natural candidates for conducting such assessments.
- These holistic assessments should be used to inform an issue prioritization process that would identify the Department's highest-priority issues for further analytic and management attention.
- Detailed joint analysis and decision-making on capability needs and solution alternatives (such as Joint Capabilities Integration and Development System (JCIDS) Capabilities Based Assessments and the new Concept Decision reviews) should be focused on the Department's identified highest-priority issues.

- Joint Concept Development & Experimentation (JCD&E) efforts should be balanced across future strategic-level discovery and concept development, support for capability gap analysis, and support for solutions development by co-evolution of doctrine, organization, training, materiel, leader development and education, personnel, and facilities (DOTMLPF).
- The extent of interaction between JCD&E and Science & Technology communities should be enhanced.
- The quality of solutions to capability gaps would greatly benefit from more competition among multiple sponsors and multiple alternative solutions.
- In order to speed the delivery of capabilities to the joint warfighter, schedule risk should be given greater weight in program decisions (in accordance with “time-defined acquisition”).
- Assignment of programs to capability categories and “portfolios” should be tailored to specific needs and contexts.
- Definitions of near-, mid-, and far-term timeframes should be standardized across processes.

Analytic Framework for Improving Capabilities-Based Planning Processes

The processes that DoD has used to conduct force employment planning and capabilities development planning have evolved considerably in the decades since the Department’s creation. Consistent themes driving the evolution of these processes have been the need for greater jointness, efforts to emphasize outputs rather than resource inputs, and characterizing resources in terms of capabilities to achieve effects rather than specific weapon systems. Though authorities, priorities, and process names have changed, the questions that planning processes must address have endured. These fundamental questions include:

1. What do military forces need to be prepared to do? When?
2. Are the capabilities that are or will be available adequate and balanced?
3. What are the priority issues requiring greater effort?
4. What are the priority capability gaps within these issues?
5. How should the priority gaps be addressed?
6. What programs can be decremented to fund higher-priority capability gaps?
7. What affordable mix of programs will provide sufficient capability at acceptable risk?
8. Is the system executing the decisions that were made?

DoD’s planning processes must be designed to provide rational, integrated answers to these questions. From this perspective, the questions provide a useful analytic framework with which to 1) describe how current processes address these questions; 2) evaluate the key challenges that demand reform; and 3) generate options for improvement.

Joint Analysis and Decision Support

An important theme links all but the last of the eight questions posed above: the answer to each depends upon the results of some kind of mission analysis. The term “mission analysis” here refers to many different types of analyses that may vary widely in scope and levels of fidelity, but share the following characteristics: definition of mission objectives and assessment of the adequacy of existing or alternative capabilities to achieve those objectives. One of the paper’s main themes is that efficient, rational decision support for capabilities development at the DoD headquarters level depends on high-quality joint mission analysis that is managed by joint organizations and adopts the perspective of the joint force.

In principle, DoD currently operates four parallel, overlapping processes that are designed to conduct and manage joint mission analysis for capabilities development planning. They are: COCOM mission analyses; the Enhanced Planning Process (EPP); Joint Capabilities Integration and Development System (JCIDS); and the Analytic Agenda.

All four of these processes have similar inputs, outputs, and participants. But two important problems inhibit their utility in capabilities-development decision-making. First, the timing of these process outputs is not well coordinated with the Department’s key planning decision points. Second, these processes are not well coordinated with one another. While each process may legitimately claim a definitive perspective on some capability needs issues at any given time, none can claim an integrated perspective on all issues on a predictable, dependable schedule. This means that senior decision-makers, themselves, serve as the first and last points of integration in the Department for answering the question “are the capabilities that are or will be available adequate and available?”

There is a clear need to improve the synchronization of the multiple joint mission analysis activities currently supporting capabilities development planning. This paper proposes that joint mission analysis be designed and executed at three different notional “levels” and in four major process steps.

- Level 1 – Issue Identification and Prioritization: Low resolution, holistic, force-wide analysis of the current force or the “programmed force” and its assigned missions to generate first-order assessment and prioritization of capability gaps, excesses, and risk. This step identifies the most important problems to be studied in greater depth, and at the same time identifies capabilities that may be lower in priority or overabundant and thus potential “bill-payers” for higher priority needs.
- Level 2 – Capability Assessments: Medium and high-resolution analysis of prioritized capability issues. Whereas the first step identifies the most important problems to be studied, this step carries out those studies to identify the specific problems that need to be solved through the development of new capabilities.
- Level 3 – Solution Development: High resolution analysis of alternative DOTMLPF and policy approaches and solutions to the prioritized “problems to be solved.” This step aims to identify the best options for solving the most important capability problems.

- Level 1 – Trade-off Analysis: Programmatic trade-off analysis based on the solutions generated at level 3 and the lower-priority capabilities identified in any earlier step. This step returns to the broad lens of level-1 analysis.

Two common threads that are critical to the conduct of joint mission analysis are scenarios and joint concepts. In the past few years, the Department has created a robust set of products, processes, and authorities for developing joint scenarios and data: the Analytic Agenda. While the Analytic Agenda has achieved considerable progress in implementing its objectives, opportunities to make significant improvements still remain. Improvements suggested in the paper address the breadth of the available set of scenarios; the scenario selection process; and scenario time frame considerations.

Joint concepts are the second key ingredient of mission analysis. From doctrinal concepts embedded in current operation plans (OPLANs) to transformational concepts for the employment of yet-to-be developed technologies, joint concepts are critical drivers of the analysis of capabilities and associated resource allocation issues. JCD&E that supports capabilities development planning can and does take different forms based on the nature of the problem being addressed and, in particular, the time frame of the problem being addressed. Three principal issues related to JCD&E, addressed in the report are as follows:

- Joint concepts overreach in time and purpose, and are not equally amenable to experimentation.
- Future joint concepts and capability needs are not shaped by an informed understanding of future technological possibilities.
- Planning horizons conflict and overlap.

Emerging Issues in Acquisition Processes

Recent recommendations from the Defense Acquisition Performance Assessment Project and the 2006 Quadrennial Defense Review (QDR) are under consideration by the Institutional Reform and Governance Roadmap implementation team. Some of the changes that may emerge from this effort would have significant implications for capabilities development planning processes, and include the following:

- Capital Account for Major Defense Acquisition Programs (MDAPs)
- Time-Defined Acquisition
- Risk-Based Source Selection Process
- Integration of Requirements; Acquisition; and Planning, Programming, Budgeting, and Execution (PPBE) processes
- Continuous Decision-making Process
- Strategic and Tactical Acquisition Reform

Additionally, the QDR Report stresses the need to view acquisition as portfolios of joint capabilities rather than as individual stove-piped programs. Process changes being considered in this regard focus on aligning program authority and accountability through joint capability portfolios and on improving the integration of “systems of systems.” The

paper offers three different acquisition management options for a hypothetical system of systems supporting a given joint capability area. The three options provide increasing degrees of centralized acquisition authority and structure to the management of the composite capability provided by the system of systems.

An Integrated Process for Capabilities Development Planning

Finally, the paper presents a potential overarching integrated process for capabilities development planning in order to bring together many of the key principles and process options presented. The paper concludes by addressing some of the analytic and organizational challenges and considerations likely to arise in the implementation of the integrated process offered. Whichever scheme is ultimately employed to improve the integration of capabilities development planning processes, it must be sensitive both to the need for better support to decision-makers and to the feasibility of the organizational change that it demands.

Report Organization

The report is divided into six main chapters and a set of appendices.

- Chapter 1 defines the questions being addressed, the study scope, and provides a brief overview of the evolution of CBP and its supporting processes.
- Chapter 2 presents the analytical approach and framework that the study team employed to assist in defining the problem and in developing and evaluating options for improvement. It also identifies prerequisites for aligning capabilities development analyses and features that capabilities development planning should incorporate.
- Chapter 3 identifies the most important decisions and decision points in DoD's capabilities development planning cycles and offers options for improving the alignment of planning process output with those decision points and enhancing the Chairman's ability to provide strong advice to the Secretary and the President.
- Chapter 4 outlines the needs and options for enhancing the quality of decision support for capabilities development, through changes in the management and focus of joint analysis, scenario development, concept development and experimentation, and acquisition.
- Chapter 5 presents an integrated process for capabilities development planning activities that incorporates the principles and options laid out in the preceding chapters.
- Chapter 6 presents a few considerations for implementation of process integration options and for additional research.

The report appendices provide overviews and other background detail on the functioning of current capabilities development planning processes.

This page intentionally blank.

Chapter 1: Study Purpose and Background

Introduction

The study presented in this report was sponsored by the Joint Staff's Director for Force Structure, Resources, and Assessment (J-8) and was conducted by a cross-divisional team of analysts from the Institute for Defense Analyses (IDA) during the first half of 2006. The goal was to produce an analytic framework and substantive foundation for creation of a Chairman of the Joint Chiefs of Staff Instruction (CJCSI) on the implementation of "capabilities-based planning" processes in the Department of Defense (DoD).

Capabilities-based planning (CBP) refers to a set of Pentagon planning processes and principles that have been in development over the past several years within the Office of the Secretary of Defense (OSD) and the Joint Staff. The overarching goal of CBP is to improve the quality of DoD planning in general and, in particular, to improve the responsiveness of resource employment and allocation to an increasingly dynamic strategic environment. Accordingly, processes supporting CBP must ensure that current and future joint force commanders are provided the capabilities they need to accomplish assigned missions, in the right time frames and in a fiscally-constrained environment.

The study was initiated on the premise that processes supporting CBP are not fully integrated with one another today and are not fully aligned with the congressional budget cycle that drives resourcing decisions in the Department. The main goals of the study mirror those established by the study sponsor for the development of a CJCSI; namely, to:

1. Identify key planning processes.
2. Identify roles, responsibilities, and authorities for each key process.
3. Identify and map the connections and relationships among the key processes, focusing specifically on inputs and outputs required for useful interactions.
4. Identify key decision points for the key processes.
5. Identify the appropriate sequencing of processes, so that the outputs of one serve as timely inputs to the next.
6. Enable the aggregation of process outputs in a way that provides effective support to senior leader decision-making.¹

The study addressed each of these six goals; however, the focus of this paper is on the last three – the goals that most directly demand options for improving the current operation of DoD planning processes. The main body of the paper focuses on the challenges and opportunities associated with process integration rather than on descriptions of current processes and their various linkages. This kind of descriptive material can be found in the report appendices and is organized by the six major planning processes identified by the study sponsor:

1. The Planning, Programming, Budgeting, and Execution (PPBE) process
2. Strategic Guidance

3. Analytic Agenda
4. Joint Capabilities Integration and Development System (JCIDS)
5. Joint Concept Development and Experimentation (JCD&E)
6. The Defense Acquisition System

In keeping with guidance from the study sponsor, the report focuses particular attention on those processes by which the Chairman of the Joint Chiefs of Staff (hereafter referred to as Chairman or CJCS) fulfills his statutory role as the spokesman for the commanders of the combatant commands (COCOMs) on the operational requirements of their commands, and the responsibilities assigned to him by law to prepare strategic plans; to advise the Secretary of Defense (hereafter referred to as the Secretary or SecDef) on critical deficiencies and strengths in force capabilities and assess the effect of such deficiencies and strengths on meeting national security objectives and policy and on strategic plans; to advise the Secretary on the priorities of the requirements identified by the commanders of the COCOMs; to advise the Secretary on the extent to which the program recommendations and budget proposals of the military departments and other DoD components conform with established priorities; and to submit to the Secretary alternative program recommendations and budget proposals in order to achieve greater conformance with those priorities.²

Capabilities Development Planning vs. Force Employment Planning

The study was also shaped by a crucial choice in its scope. It is focused on those planning processes in the Department that are designed to develop and field capabilities for the future joint force; it does not address in detail those planning processes focused on the allocation and employment of existing capabilities. These two planning domains are referred to in this report as “capabilities development planning” and “force employment planning,” respectively.

Joint doctrine describes how the President and Secretary of Defense exercise authority and control of the armed forces through “two distinct branches of the chain of command” as shown in Figure 1.1.

One branch runs from the President, through the SecDef, to the COCOM commanders for missions and forces assigned to their commands. This is the “Force Employment Planning” chain. Key guidance documents issued in this chain are the Unified Command Plan (UCP), the Contingency Planning Guidance (CPG) and accompanying Strategic Guidance Statements (SGSs), the Security Cooperation Guidance (SCG), the Joint Strategic Capabilities Plan (JSCP), and the Global Force Management Guidance (GFMG). The Chairman’s role with respect to this chain of command is carefully prescribed in law and DoD directives. He is a conduit for communications, has no command authority, and the responsibility assigned to him by the SecDef for overseeing the activities of the combatant commands does not alter their responsibility or accountability to the Secretary.

The other branch of the chain of command is used for purposes other than operational direction of forces and runs from the President through the SecDef to the Secretaries of the Military Departments. This is the “Capabilities Development Planning”

chain. Key guidance documents issued in this chain are the Quadrennial Defense Review (QDR) report, the Strategic Planning Guidance (SPG), the Joint Programming Guidance (JPG), and the Transformation Planning Guidance (TPG).³ Also included are the documents used to record major force planning decisions, such as Program Decision Memorandums (PDMs), Program Budget Decisions (PBDs), and Management Initiative Decisions (MIDs). The Chairman has no formally prescribed role in this chain of command but, as noted above, he serves by law as spokesman for the commanders of the COCOMs and has specific responsibilities for advising the Secretary on programs and budgets as well as on requirements.

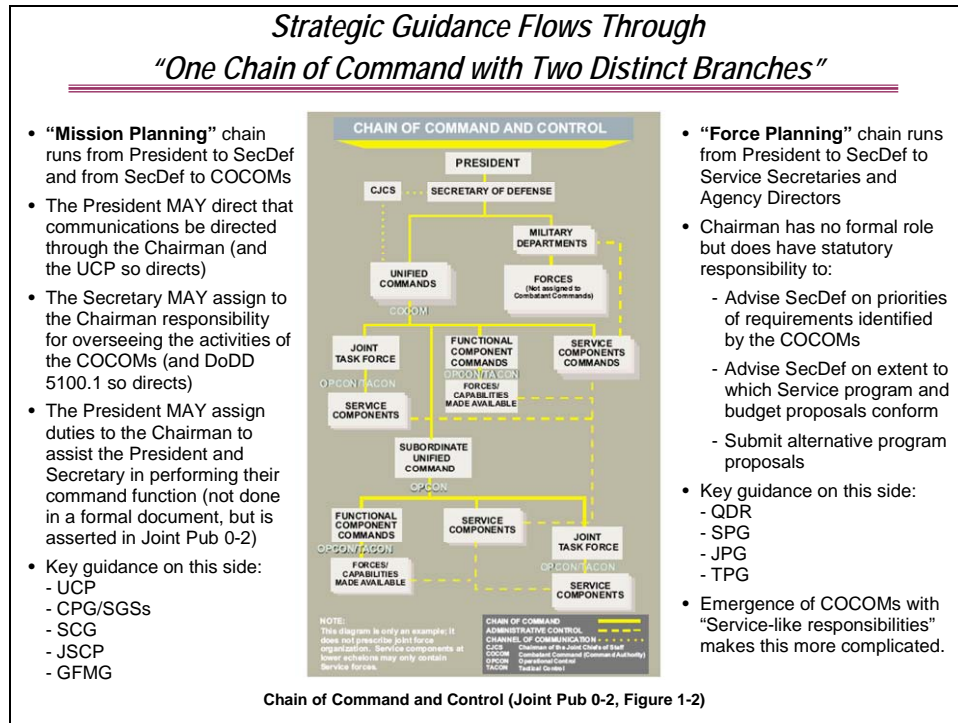

Figure 1.1: Force Employment and Capabilities Development Planning Guidance Channels

These two planning domains are sufficiently distinct to allow for productive examination of each individually. Their separation in this report should in no way be interpreted as a suggestion that integration across planning domains is not essential for the effective implementation of capabilities-based planning. To the contrary, linking contingency plans to resource allocation processes is fundamental to achieving the goals of CBP.

As previously noted, detailed descriptions of the various processes that collectively constitute capabilities development planning are provided in appendices to this report. By way of introduction, however, the next few pages provide a brief overview of the recent evolution of capabilities-based planning and the ways in which DoD has attempted to improve its planning processes over the past several years.

Origins and Evolution of Capabilities-Based Planning

The current drive toward capabilities-based planning originated during the 2001 QDR, but the idea behind it goes back farther, at least to the 1995 report of the Commission on Roles and Missions of the Armed Forces (CORM).

“Roles and Missions” connotes the struggles between the Services that began in the late 1940s when DoD was formed. The National Security Act of 1947 resolved some of the bigger issues (it established the Air Force, provided for naval aviation, and specified that the Marine Corps would include land combat forces as well as aviation), but Congress left the details of Service functions to the executive branch. An Executive Order set forth the functions of the armed forces, but responsibility for air missions remained contentious, and Secretary of Defense James Forrestal gathered the Service Chiefs in Key West, Florida to negotiate a settlement. The resulting Key West Agreement of 1948 specified the functions that each Service was responsible for and empowered the Services to establish “requirements” to fulfill those functions. The assignment of functions was codified in a DoD Directive that remains in effect today.⁴

The Goldwater-Nichols Act of 1986 required the CJCS to review roles and missions every three years and submit recommendations to the Secretary of Defense. After two such reports fell short of expectations, Congress established the CORM in 1994 to “review the efficacy and appropriateness for the post-Cold War of the current allocations among the Armed Forces of roles, missions, and functions . . . and make recommendations for changes.”⁵

The CORM rejected the traditional functions-based approach of Key West and advocated in its place an approach based on capabilities:

Our most important finding is that traditional approaches to roles and missions are no longer appropriate. The context has changed significantly in the years since the 1948 Key West Agreement addressed the question of who should do what in the US Military.

The question is no longer “who does what,” but how do we ensure that the right set of capabilities is identified, developed, and fielded to meet the needs of unified commanders. The Services, the defense agencies, OSD, and the Joint Staff – who make these decisions and develop these capabilities – are at the forefront of this effort.⁶

The CORM found a need for a central vision to harmonize the Services’ views of joint warfighting, drive joint requirements, and give the Services guidance regarding the capabilities they should supply to unified military operations. Without a unifying concept for joint warfighting, the CORM stated, each Service was trying to deliver what its own leaders viewed as the best possible set of specific capabilities – without taking into account similar capabilities provided by the other Services. The CORM therefore recommended that capabilities and requirements be reviewed in the aggregate, arguing that “only by approaching capabilities in the aggregate, from the combatant commanders’ perspective rather than the Services’, can the ‘who needs what’ question be answered.”⁷

The “central vision” advocated by the CORM was realized with Joint Vision 2010, “the conceptual template to provide a common direction for use by the Services in

developing their unique capabilities within a joint framework of doctrine and programs as they prepare to meet an uncertain and challenging future.”⁸ The first QDR in 1997 continued down the CBP path when it sought to ensure “a force capable of carrying out today’s missions with acceptable strategic risk, while allowing us to stabilize our investment program in order to achieve the future joint force capabilities described in Joint Vision 2010.”⁹

The effort to *formally* implement a capabilities-based approach began with the 2001 QDR:

A central objective of the review was to shift the basis of defense planning from a “threat-based” model that dominated thinking in the past to a “capabilities-based” model for the future. This capabilities-based model focuses more on how an adversary might fight than specifically whom the adversary might be or where a war might occur. It recognizes that it is not enough to plan for large conventional wars in distant theaters. Instead, the United States must identify the capabilities required to deter and defeat adversaries who will rely on surprise, deception, and asymmetric warfare to achieve their objectives.¹⁰

Responding to that guidance, various parts of the Pentagon began to revamp their “stovepipe” processes to reflect a capabilities-based approach. In the absence of an overall framework to guide them, however, the processes that together are intended to constitute CBP were conceived independently and are not adequately synchronized, either with one another or with the recurring rhythms of the congressional budget cycle. The individual processes that contribute to capabilities-based planning are discussed below.

Processes of Capabilities-Based Planning

The main processes that constitute capabilities development planning are PPBE, Strategic Guidance, Analytic Agenda, JCIDS, JCD&E, and Acquisition. Another critical set of processes support force employment planning, such as adaptive planning, readiness, and global sourcing. These are also addressed briefly in this section. Though the functions these processes perform are enduring, important features of each process have recently changed. The most substantial recent changes are summarized here. The section also includes an overview of a new Concept Decision process designed to address capability needs (performance specifications), resource allocation (cost) and acquisition schedules in one decision process and the development of Joint Capability Areas (JCAs) designed to provide a common lexicon across all planning processes.

PPBE. In 2003, MID 913 directed implementation of a two-year planning cycle to replace the Planning, Programming, and Budgeting System (PPBS) that had served as DoD’s central strategic planning, program development, and resource determination process since the 1960s.¹¹ In addition to its newly biennial format, PPBS was altered to include an “execution and performance monitoring” phase (hence the revised acronym of PPBE). To date, implementation of this change remains in its early stages.

Strategic Guidance. Shortly after the issuance of MID 913, further changes were made to the strategic guidance elements of PPBS. The Defense Planning Guidance (DPG), which previously had been produced during the planning phase of PPBS and provided guidance for the programming phase, was replaced in 2003 by two new documents. The SPG, initially to have been issued in December, was described as a single, fiscally informed

document that replaced the policy and strategy sections of the DPG. The JPG, to be issued in the spring, would replace the programmatic elements of the DPG and would record the decisions reached during the planning phase.¹²

Analytic Agenda. The CORM's recommendation to "review capabilities in the aggregate" began with deep attack weapons. The Commission report noted that the Services had fielded a mix of land-based ballistic missiles, sea-based cruise missiles, and a growing inventory of precision-guided weapons and standoff weapons delivered by aircraft; but because no one in DoD had specific responsibility for specifying the overall number and mix of deep attack systems, it was not clear that DoD had the correct balance of these various weapons. The CORM therefore recommended that DoD conduct an assessment of all the Services' deep attack systems to determine appropriate force size and mix.¹³

Acting on this recommendation, the Department undertook the Deep Attack Weapons Mix Study (DAWMS). The results of the study were inconclusive, in large part because the analytical tools used were seen as inadequate by many stakeholders. A Defense Science Board (DSB) task force formed to assess the analytical tools and models employed in DAWMS highlighted "the great challenge in realistically modeling large-scale joint military operations against opposing forces, and then drawing acquisition conclusions from the results." The DSB chairman summarized the results as follows:

In sum, while the DAWMS effort is being conducted with the best available methods, our confidence in the modeling results must be limited, and our conclusions and acquisition plans must be shaped by military experience and common sense. It is important for the Department to move forward with the development of greatly improved approaches for modeling such large-scale operations. Only by such an advance will it be possible to evaluate the capabilities of various force-structure options as well as the impact of new tactics and weapon systems.¹⁴

The difficulties in capabilities assessment noted during DAWMS are emblematic of the challenges that the Analytic Agenda was created to address. Directed to be established by the May 2002 DPG,¹⁵ the Analytic Agenda produces joint scenarios and data and manages some major joint studies for the purposes of improving the quality and commensurability of analyses supporting planning and programming throughout the Department.

JCIDS. Dissatisfaction with the Requirements Generation System, expressed in a SecDef memorandum,¹⁶ resulted in the creation of JCIDS. The TPG issued by the Secretary in April 2003 described a strategy for implementing transformation. The central element was termed "Risk Adjudication Using Future Operating Concepts." The stated objective was to balance the requirements of current operations against the need to invest in capabilities to support future concepts. This portion of the strategy would have two parts:

- **Reformed Capabilities/Identification Process.** The TPG called for reform of the requirements system to permit investments in transformational capabilities based on joint operating concepts.
- **Transformed Strategic Analysis.** The objective was an analytic process able to compare risks across time and between multiple theater-level operations.

The Chairman responded to the Secretary's call for reform of the requirements system with the creation of JCIDS. The two documents that promulgated JCIDS—a CJCSI and a Chairman's Manual (CJCSM)—were initially published in June 2003, revised in March 2004, and revised again in May 2005.¹⁷ The current directive describes JCIDS as a joint, concepts-centric analysis process designed to identify capability gaps, assess their risk and priority, and identify approaches to address them:

JCIDS implements a capabilities-based approach that better leverages the expertise of all government agencies to identify improvements to existing capabilities and to develop new warfighting capabilities.¹⁸

At the same time the Joint Staff was implementing JCIDS, the Secretary of Defense chartered the Joint Defense Capabilities Study “to examine the process and organizational changes necessary to implement a capabilities-based approach across the Department.”¹⁹ The study, chaired by former Under Secretary of Defense for Acquisition, Technology, and Logistics (USD(AT&L)) Pete Aldridge, is often referred to as the “Aldridge Study,” and the process it recommended as the “Aldridge Process.”

The Aldridge Study found that historically, the Services had defined capability needs, developed alternatives, and selected and resourced solutions. Under the old Requirements Generation System, Services presented their mission need statements to the Joint Requirements Oversight Council (JROC) for approval. The JROC approached candidate requirements and resources on a case-by-case basis rather than with a DoD-wide view, and was thus predisposed to accept Service-defined needs. The lack of strong combatant commander influence resulted in capabilities being “pushed” to the warfighters rather than their identifying and “pulling” needed capabilities from the force providers.

The Aldridge Study proposed giving combatant commanders a larger role in shaping defense strategy and using operating concepts and the unique demands of various theaters to drive assessment of joint needs. The role of the Services would be to offer proposed solutions to meet those joint needs. Selection of the best alternatives would be preceded by analysis, conducted by teams from OSD, the Joint Staff, and the Services, with combatant command representation to ensure the analysis reflects a realistic assessment of current and future warfighting concepts.²⁰

The Joint Capabilities Development Process (“Aldridge Process”) initiated by the Secretary based on the results of the Aldridge Study overlaps and in some ways conflicts with JCIDS processes initiated by the Chairman. Both depend on the same limited analytical resources – JCIDS for “capabilities-based assessment” (CBA) and the Aldridge Process for the “Enhanced Planning Process” (EPP). Under JCIDS, Functional Capabilities Boards (FCBs) provide analytical support for JROC discussions and decisions on capability needs, joint concepts, and programmatic issues.²¹ Under the Aldridge Process, the “analysis engine” at the heart of the EPP would define joint needs, identify gaps and excesses in current and future capabilities, conduct top-level trade analyses in capability terms, assessing alternatives nominated by the Services to fill capability gaps, and prioritize these actions to ensure that the most pressing issues are fully resourced.²²

The Aldridge Study recognized that many of the skill sets needed to populate this “analysis engine” reside in the Joint Staff and OSD, and described the analysis engine as “essentially a hybrid of today's program review issue teams and the Functional

Capabilities Boards.”²³ But the idea of amalgamating the JROC-controlled FCBs with the program review issue teams from OSD never made it into implementing guidance, and the tension between the two capabilities-based approaches remains unresolved. CJCSI 3137, which provides guidance on the operation of the FCBs, acknowledges the tension this way:

The EPP provides the Secretary of Defense with programmatic choices and recommendations based on capability-based analyses of major issues. The Executive Committee (EXCOM), consisting of the Director, PA&E [Program Analysis and Evaluation], the Director, Force Structure, Resources, and Assessment Directorate (DJ-8) and the Principal Deputy Under Secretary of Defense (Policy), provides EPP oversight and guides the process. FCBs may provide members to support EPP issue teams that perform analytical work in accordance with approved terms of reference.²⁴

In plain English, the same set of analysts (FCB members) could easily be looking at the identical issues under two different charters, providing recommendations to two different decision-making bodies – the JROC and the EXCOM – on two different time lines. Resolving the tensions between JCIDS and the Aldridge Process is a major consideration in this report’s discussion of improving analytic support to senior decision-making in Chapter 4.

JCD&E. The April 2003 TPG established “Risk Adjudication Using Future Operating Concepts” as a central element of the transformation strategy and said future joint operating concepts were the key. The TPG directed the Chairman to develop one overarching joint concept and to direct and oversee the development of four subordinate joint operating concepts: homeland security, stability operations, strategic deterrence, and major combat operations for the mid-term, “just beyond the Future Years Defense Plan (FYDP).” Later, SPG 06-11 directed the Chairman to present a plan for revisions to future joint concepts. CJCSI 3010.02B, Joint Operations Concepts (JOpsC) Development Process, “provides guidance for joint concept development and synchronizes the efforts of the joint concept community in the DoD capabilities-based approach to transformation.”²⁵ Instead of concentrating “just beyond the FYDP,” the current instruction calls for concepts to cover a period 8-20 years into the future. Aligning time-frames of the separately developed planning processes is an area that requires significant attention and is addressed in this report.

Acquisition. The Defense Acquisition System is the management process by which DoD provides weapon systems, automated information systems, and other materiel systems to fill validated capability needs. Acquisition directives were revised in 2003 and now reflect that the linkage between acquisition and capabilities development planning is through JCIDS. The capability needs and acquisition management systems use joint concepts, integrated architectures, and an analysis of doctrine, organization, training, materiel, leadership and education, personnel, and facilities (DOTMLPF) in an integrated, collaborative process to define desired capabilities and guide the development of affordable systems. The Chairman and Vice Chairman, with the assistance of the JROC, provide advice regarding military capability needs for defense acquisition programs.

One particularly important recent development in this area is a pilot initiative resulting from the 2006 QDR that aims to transform the “concept decision” that occurs in the current acquisition process. The “concept” referred to here is a postulated materiel

solution to provide or enhance some capability identified in a JROC-approved Initial Capabilities Document (ICD). Both the original and the new concept decision processes are depicted in Figure 1.2.

In the current “As Is” process, “Concept Refinement begins with the Concept Decision. The MDA [Milestone Decision Authority] designates the lead DoD Component(s) to refine the initial [materiel] concept selected, approves the AoA [Analysis of Alternatives] plan, and establishes a date for a Milestone A review. The MDA decisions shall be documented in an Acquisition Decision Memorandum (ADM). This effort shall normally be funded only for the concept refinement work. The MDA decision to begin Concept Refinement DOES NOT mean that a new acquisition program has been initiated.”²⁶ Here the Concept Decision essentially results in the approval of a plan to conduct an analysis of alternative materiel solutions.

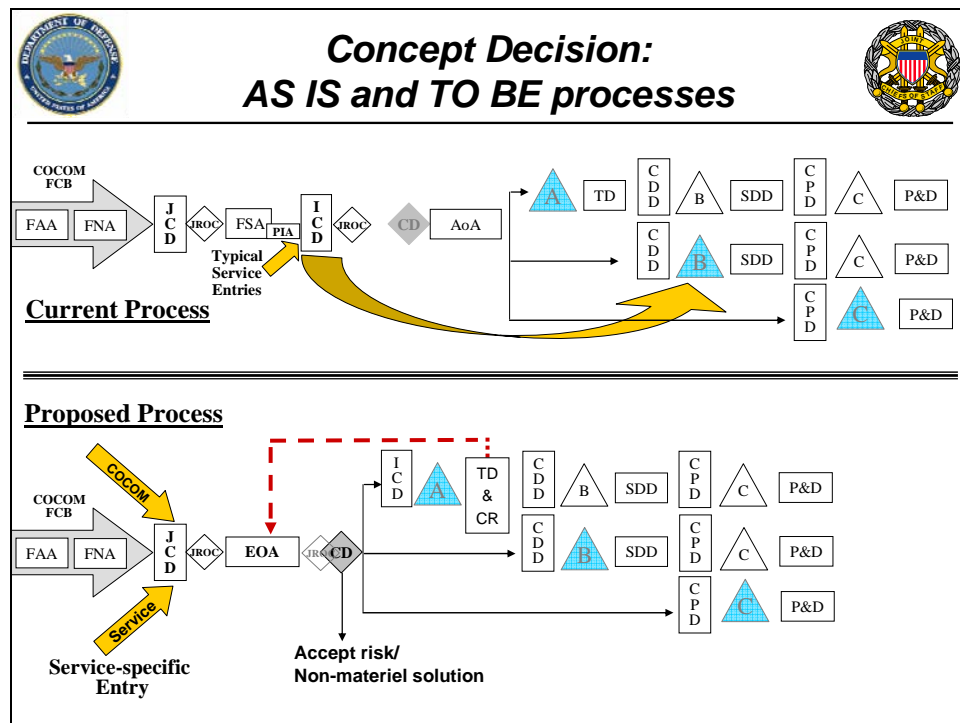

Figure 1.2: Concept Decision Plan²⁷

In the proposed “To Be” process, the Concept Decision is the point at which the requirements, acquisition, and resource processes converge at the point of investment. “Our goal is to inform the leadership of each of the processes so that early tradeoffs and solution optimization can occur prior to the point of significant commitment to future investment. Action items for each process that emerge from this joint investment decision will be captured in a Concept Decision Memorandum.”²⁸ Rather than an MDA, the USD(AT&L); the Director, PA&E; and the Vice Chairman of the Joint Chiefs of Staff (VCJCS) would approve the Concept Decision Memorandum. If successful, this process will provide greater integration and feedback among JCIDS, PPBE, and Acquisition processes, and affect the JROC and supporting FCB processes and practices.

A related effort is the creation of Capability Portfolio Managers to manage the development of joint capabilities as opposed to individual programs, thus enhancing integration and interoperability. Four experiments are under way to develop governance, management, and implementation procedures for (1) Joint Command and Control, (2) Joint Network Operations, (3) Battlespace Awareness, and (4) Joint Logistics Capability portfolios. The contents of these portfolios and the use of portfolios in capability development planning to align programs with joint capabilities, tasks, and military units is work in progress. Defining one portfolio construct that fits the multiple responsibilities of the various organizations involved in capabilities development planning is proving to be a difficult challenge.

Joint Capability Areas. Another recent development in the implementation of CBP that cuts across capabilities development processes is the creation of the Joint Capability Areas (JCAs).²⁹ The goal of the JCAs is to provide DoD with a common lexicon for defining and describing capabilities that have historically been defined and described in different ways by different organizations throughout the Department. Both the Aldridge Study and the 2004 SPG called for the creation of a common capability lexicon, which was then developed by the Joint Staff under the auspices of the Operational Availability 2005 study. In May 2005, the SecDef directed the Department to begin using the JCAs “where appropriate” and identified some specific venues for their use, including Defense Planning Scenarios, acquisition planning, joint concept development, JCIDS, and the organization of program and budget databases.³⁰ Implementation of this guidance continues in each of these areas and others, though the exact role played by the JCAs continues to evolve.

Force Employment Planning Processes. Finally, though this paper does not address force employment planning processes in detail, these activities are integral to a holistic view of capabilities-based planning. They largely determine whether and how current joint force commanders are provided the capabilities they need to accomplish assigned missions in the near-term, and outputs from these processes, such as the combatant commanders’ Integrated Priority Lists (IPLs) and Joint Quarterly Readiness Reports (JQRRs), are important inputs to capabilities development planning. Processes of force employment planning include Adaptive Planning – the joint capability to create and revise plans rapidly and systematically (including the capability to analyze a mission, identify stated and implied tasks, and rapidly determine the friendly capabilities and conditions needed for mission success).³¹ They include the readiness reporting and assessment process – the joint capability to monitor and evaluate the preparedness and responsiveness of combatant forces and DoD combat support agencies to perform assigned missions.³² And they include the Global Force Management process – the joint capability to account for forces committed to ongoing operations and constantly changing unit availability, and to identify the most appropriate and responsive capabilities that best meet combatant commander requirements.³³

Role of the Chairman in Capabilities Development Planning

This study was requested and performed under the sponsorship of the Joint Staff Directorate for Force Structure, Resources, and Assessment (J-8). It therefore looks at capabilities development planning through the lens of responsibilities and authorities assigned to the Chairman and the Joint Staff.

By law, the Chairman is the principal military adviser to the President, the National Security Council, and the Secretary of Defense. He also serves as the spokesman for the combatant commanders, especially with regard to their operational requirements. In performing such functions, the law directs the Chairman to confer with and obtain information from the combatant commanders with respect to the requirements of their commands; to evaluate and integrate such information; to advise and make recommendations to the Secretary of Defense with respect to the requirements of the combatant commanders, both individually and collectively; and to communicate the requirements of the combatant commanders to other elements of the Department.³⁴ Congress later underscored this role of the Chairman by requiring him to submit an Annual Report on Combatant Command Requirements, consolidating the IPLs of the combatant commands, providing the Chairman's views on the consolidated lists, and describing the extent to which the most recent FYDP addresses the requirements on those lists.³⁵

To assist the Chairman in fulfilling these statutory responsibilities, Congress directed the Secretary of Defense to establish the JROC. In addition to any other matters assigned to it by the President or Secretary of Defense (of which none are currently documented), the mission of the JROC is to assist the Chairman in (1) identifying and assessing the priority of joint military requirements; (2) evaluating the cost, schedule, and performance criteria of acquisition programs and identified alternatives; and (3) as part of its mission to assist in assigning joint priority among existing and future programs meeting valid requirements, ensure that the assignment of such priorities conforms to and reflects resource levels projected by the Secretary through defense planning guidance.³⁶

In addition to advising the Secretary on the priorities of requirements identified by the combatant commanders, the Chairman is charged by law with advising the Secretary on the extent to which the program recommendations and budget proposals of the military departments and other DoD components conform with those priorities; submitting alternative program recommendations and budget proposals, within projected resource levels and guidance provided by the Secretary, in order to achieve greater conformance with those priorities; and assessing military requirements for defense acquisition programs.³⁷

Report Organization

The remainder of this report is divided into five main chapters and a set of appendices.

- Chapter 2 presents the analytical approach and framework that the study team employed to assist in defining the problem and in developing and evaluating options for improvement. It also identifies prerequisites for aligning capabilities development analyses and features that capabilities development planning should incorporate.
- Chapter 3 identifies the most important decisions and decision points in DoD's capabilities development planning cycles and offers options for improving the alignment of planning process output with those decision points and enhancing the Chairman's ability to provide strong advice to the Secretary and the President.

- Chapter 4 outlines the needs and options for enhancing the quality of decision support for capabilities development, through changes in the management and focus of joint analysis, scenario development, concept development and experimentation, and acquisition.
- Chapter 5 presents an integrated process for capabilities development planning activities that incorporates the principles and options laid out in the preceding chapters.
- Chapter 6 presents a few considerations for implementation of process integration options and for additional research.

Finally, the report appendices provide overviews and other background detail on the functioning of current capabilities development planning processes.

End Notes

- ¹ Adapted from J-8 /JCD, “Capabilities-Based Planning: Framework” briefing, December 2005.
- ² Title 10 United States Code, Sections 163(b)(2) and 153(a)
- ³ The TPG was published in April 2003. It is not clear whether this document will be revised and reissued, or simply subsumed into some other document such as the SPG.
- ⁴ DoD Directive 5100.1, Functions of the Department of Defense and Its Major Components, is the lineal descendent of the Key West Agreement. The directive has been revised several times over the years, the last time in 1987 to incorporate the Goldwater-Nichols Act. It was reissued (not revised) August 1, 2002.
- ⁵ Public Law 103-160, National Defense Authorization Act for Fiscal Year 1994, Subtitle E.
- ⁶ Directions for Defense, the Report of the Commission on Roles and Missions of the Armed Forces, May 24, 1995, p. vii.
- ⁷ Directions for Defense, p. 2-27.
- ⁸ Joint Vision 2010, 1995, p. 1.
- ⁹ Report of the Quadrennial Defense Review, May 1997, p. v.
- ¹⁰ Quadrennial Defense Review Report, September 30, 2001, p. IV.
- ¹¹ Management Initiative Decision (MID) 913, “Implementation of a 2-year Planning, Programming, Budgeting, and Execution Process,” May 22, 2003.
- ¹² Memorandum from the Secretary of Defense Donald H. Rumsfeld, “Initiation of a Joint Capabilities Development Process,” October 31, 2003.
- ¹³ Directions for Defense, pp. 2-2, 2-27
- ¹⁴ Report of the Defense Science Board Task Force on Deep Attack Weapons Mix Study, January 1998.
- ¹⁵ Defense Planning Guidance Fiscal Years 2004-2009, May 2002, pp. 53-54. Elements of the Analytic Agenda are codified in DoDD 8260.1, Data Collection, Development, and Management in Support of Strategic Analysis, December 6, 2002.
- ¹⁶ “White Paper on Conducting Capabilities-Based Assessment (CBA) under the Joint Capabilities Integration and Development System,” JCS J-8/Force Application Assessment Division, January 2006, p. 6.
- ¹⁷ CJCSI 3170.01E, Joint Capabilities Integration and Development System, May 11, 2005; CJCSM 3170.01B, Operation of the Joint Capabilities Integration and Development System, May 11, 2005.
- ¹⁸ CJCSI 3170.01E, p. A-1.
- ¹⁹ Honorable E.C. Aldridge, et al., Joint Defense Capabilities Study: Improving DoD Strategic Planning, Resourcing and Execution to Satisfy Joint Capabilities, Final Report, January 2004, p. 1-1. (Hereafter referred to as “Aldridge Study.”)
- ²⁰ Ibid., pp. 2-4 to 2-7.
- ²¹ CJCSI 3137.01C, The Functional Capabilities Board Process, November 12, 2004, p. B-1.
- ²² Aldridge Study, p. 2-12.
- ²³ Aldridge Study, p. 2-15
- ²⁴ CJCSI 3137.01C, pp. C-2 and C-3.
- ²⁵ CJCSI 3010.02B, Joint Operations Concepts (JOpsC) Development Process, January 27, 2006, p. 1.
- ²⁶ DODI 5000.2, Operation of the Defense Acquisition System, May 12, 2003, p. 5.
- ²⁷ James “Raleigh” Durham, “Concept Decision Implementation,” briefing to MORS Workshop on Capabilities Based-Planning, April 2006, slide 7. http://www.mors.org/meetings/cbp_II/briefs/durham.pdf
- ²⁸ Testimony of Kenneth J. Krieg Under Secretary of Defense (Acquisition, Technology, & Logistics) before the United States House Committee on Armed Services, April 5, 2006.
- ²⁹ More information on the JCAs can be found at www.dtic.mil/futurejointwarfare/cap_areas.htm
- ³⁰ Memorandum from Secretary of Defense Donald H. Rumsfeld, “Operational Availability (OA)-05 / Joint Capability Areas,” May 6, 2005.
- ³¹ Adaptive Planning Roadmap, unsigned draft, dated November 2005.
- ³² DoDD 7730.65, Department of Defense Readiness Reporting System (DRRS), June 3, 2002; CJCSI 3401.01D, Chairman’s Readiness System, December 10, 2004.
- ³³ Global Force Management Guidance FY 2005 (U), May 4, 2005, p. I-1.
- ³⁴ Title 10 United States Code, Section 151(b) and 163.
- ³⁵ Title 10 United States Code, Section 153(c).
- ³⁶ Title 10 United States Code, Section 181.
- ³⁷ Title 10 United States Code, Section 153(a)(4).



This page intentionally blank.

Chapter 2: Analytic Framework for Assessing Capabilities Development Planning Activities

Analytic Approach

Figure 2.1 illustrates the analytic approach used in the conduct of this study.

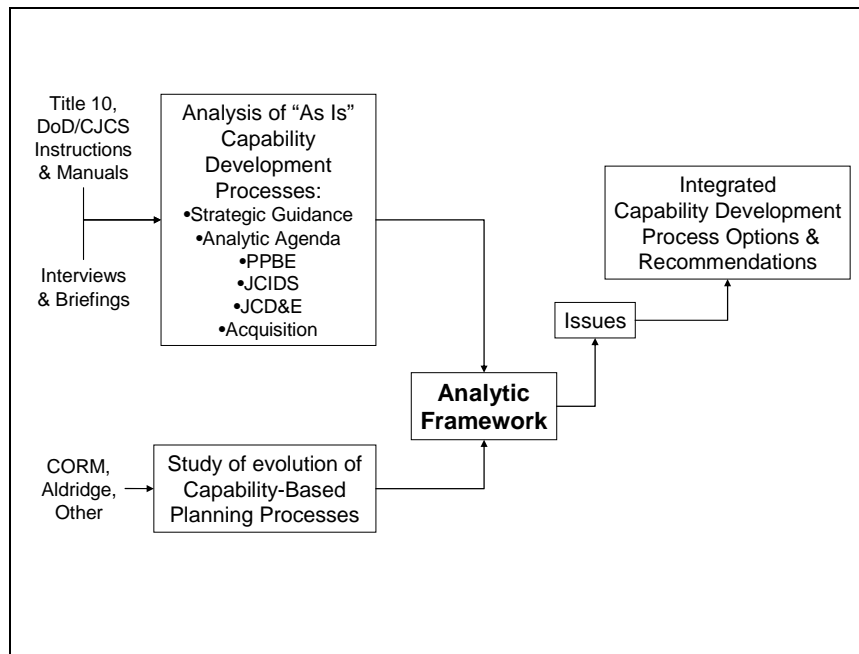

Figure 2.1: Analytic Approach

IDA assembled a cross-divisional team of subject matter experts who have detailed experience in each of the capability development processes identified by the sponsor. These analysts carefully parsed the current laws, instructions and manuals to fully understand the state of these processes. They also tracked changes that occurred in these subjects over the course of the study through frequent interactions with those responsible for the processes, participation in the April 2006 Military Operations Research Society (MORS) Capability-Based Planning Workshop, and briefing interim results to the sponsor and other stakeholders to obtain their feedback.

The subject matter experts' participation in previous studies and review of related documents provided important perspectives on the evolution of CBP and led to the development of an analytic framework for assessing the issues involved in aligning the existing processes to achieve the intended outcome. This analytic framework, described below, was used to derive the issues and points of emphasis to be stressed in the further development and implementation of CBP. Many options exist within the details of implementation. This paper provides "pros" and "cons" of alternative implementation approaches as points of departure for selecting alternative implementation approaches.

Analytic Framework: Key Questions that Capabilities Development Planning Processes Must Address

The processes that DoD has used to conduct force employment planning and capabilities development planning have evolved considerably in the decades since the Department's creation. Consistent themes driving the evolution of these processes have been the need for greater jointness, efforts to emphasize outputs (advancing US security interests - now in terms of desired effects) rather than resource inputs, and characterizing resources (programs) in terms of capabilities to achieve effects rather than specific weapon systems.¹ Though authorities, priorities, and process names have changed, the questions that the planning processes must address have endured. These fundamental questions are:

1. What do military forces need to be prepared to do? When?
2. Are the capabilities that are or will be available adequate and balanced?
3. What are the priority issues requiring greater effort?
4. What are the priority capability gaps* within these issues?
5. How should the priority gaps be addressed?
6. What programs can be decremented to fund higher-priority capability gaps?
7. What affordable mix of programs will provide sufficient capability at acceptable risk?
8. Is the system executing the decisions that were made?

DoD's planning processes must be designed to provide rational, integrated answers to these questions. From this perspective, the questions provide a useful analytic framework with which to 1) describe how current "as is" processes address these questions; 2) evaluate the key challenges that demand reform; and 3) generate options for improvement. The remainder of this chapter tackles the first of these three tasks; subsequent chapters address the second and third.

1. What do military forces need to be prepared to do? When?

In principle, strategic guidance provides the information needed for planning what military forces need to be prepared to do now and in the future. The guidance for force employment planning directs what commanders need to prepare their forces to do in the near-term. The guidance for capabilities development planning has a longer horizon.

The UCP assigns broad geographic and functional missions to COCOM commanders and provides a framework for the preparation of more detailed contingency and security cooperation planning guidance. The QDR, with its 20-year time horizon, identifies areas of emphasis for the missions that military forces need to be prepared to accomplish in the future. The QDR and the follow-on SPG provide detailed guidance and direction used in the preparation of other strategic and capabilities development planning guidance.

* The term gap is used to admit both shortfalls in needed capability due to inadequate forces and differences between current and projected practice and opportunities to employ new policy or DOTMLPF approaches.

The 2001 QDR emphasized particular geography, six operational goals, and a 1-4-2-1 force planning construct as a basis for assessing the proficiency and sufficiency of forces.² The priority mission areas and revised force planning construct from the 2006 QDR are shown in Figure 2.2. This QDR called for balancing future forces across a range of *strategic challenges* (traditional, irregular, catastrophic, and disruptive)[†], with an associated *range of military operations* (conducting combat operations against traditional armed forces, deterrence, defeating terrorist extremism, combating weapons of mass destruction, defending the homeland, shaping choices of countries at strategic crossroads), and using a *force planning construct* to size and shape the force. Though its time horizon is 20 years, the purpose of the QDR is to allow for significant revisions in guidance as deemed necessary based upon recent developments.

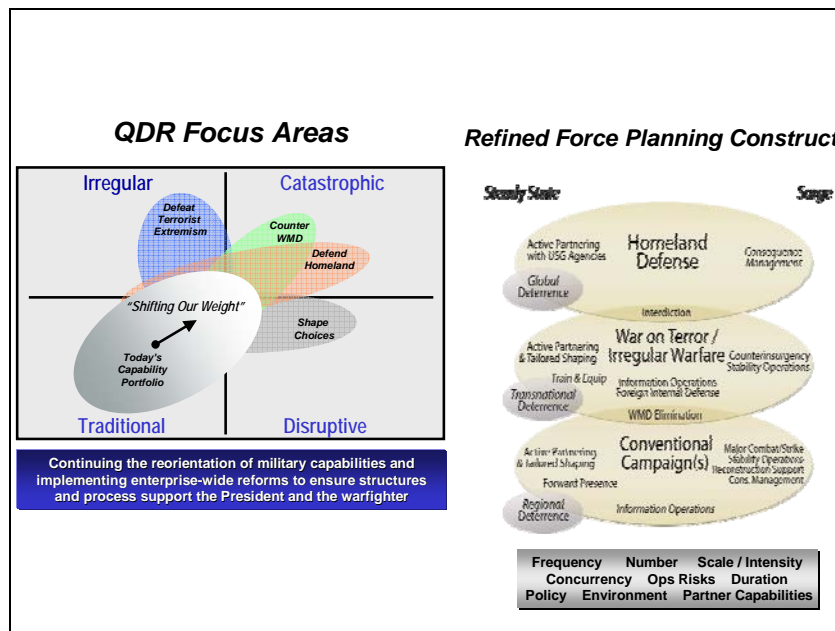

Figure 2.2: Priority Areas for the 2006 QDR and Force Planning Construct³

Direction on what missions military forces need to be prepared to do – when compared to the capabilities of current, programmed, and planned forces and opportunities for improvement – provides the means to identify capability gaps. Any changes in strategic guidance ripple through assessments of capability gaps and the development of capabilities to remedy them. The use of Strategic Guidance Statements to change planning assumptions rapidly and trigger updates of existing plans, and of Adaptive Planning to quickly produce quality plans that readily adapt to changing circumstances, can easily exceed the ability of subsequent processes to respond to those changes.⁴ Stability in strategic guidance, consistent with the actual security environment, facilitates capability development processes.

[†] Note that the first two categories refer to the type of adversary: conventional or irregular armed forces. The second two categories refer to the nature of the effects an adversary might produce: catastrophic or disruptive. It would be easier and more meaningful to map the range of military operations against two axes consisting of the type of adversary and the nature of the effect rather than the quadrants currently in use.

In practice, the time frames over which most strategic guidance applies are not specified (see Table 2.1). The specified update periods direct the guidance to be refreshed frequently, but slipping schedules are common. Updated guidance does not necessarily nullify previous guidance. In general, the guidance more clearly applies to the nearer than the more distant future. Though not considered strategic guidance, the information provided in DPSs for the mid- and far-term fills in details needed for capabilities development planning that is not contained in strategic guidance documents.

Strategic Guidance	Time Horizon	Specified Update
National Security Strategy	Unspecified	Annual
National Defense Strategy	Unspecified	Quadrennial
National Military Strategy	5-7 years ⁵	Biennial
National Military Strategies for ... ⁶	Unspecified	Unspecified
Quadrennial Defense Review	Unspecified	Quadrennial
<i>Force Employment Planning Guidance</i>		
Unified Command Plan	Unspecified	Biennial
Contingency Planning Guidance	Unspecified	Biennial
Strategic Guidance Summaries	Unspecified	As needed
Security Cooperation Guidance	Unspecified	Biennial
Joint Strategic Capabilities Plan	Unspecified	Biennial
Global Force Management Guidance	Unspecified	Biennial
<i>Capabilities Development Planning Guidance</i>		
Strategic Planning Guidance	Next FYDP	Biennial (or annual)
Joint Planning Guidance	Next budget	Biennial (or annual or rolling)
Transformation Planning Guidance	Unspecified	Unspecified
Defense Planning Scenarios	FYDP+1 and FYDP+11	Biennial

Table 2.1: Strategic Guidance Time Horizons and Nominal Updates

Strategic guidance and CBP-related directives generally describe three time frames; near-, mid-, and far-term. However, these terms are described in overlapping and conflicting ways in the various guidance documents and directives, such as the TPG, Doctrine for Planning Joint Operations, Global Force Management Guidance, the JOpsC development process, Analytic Agenda, JCIDS, and Science and Technology planning. Most guidance documents express planning horizons with respect to the FYDP.

The FYDP officially summarizes resources associated, by fiscal year, with DoD programs as approved by the Secretary or Deputy Secretary of Defense. It addresses the “prior, current, budget and program years,” shown in Figure 2.3.⁷ Here, “The planning period encompasses the upcoming FYDP (mid-term) plus a 10-year extended planning period (long-term). . . The focus is on the following major objectives: defining the

national strategy necessary to help maintain US national security and to support US foreign policy 2 to 7 years in the future; planning the integrated and balanced military forces necessary to accomplish that strategy; assuring the necessary framework (including priorities) to manage DoD resources effectively for successful mission accomplishment consistent with national resource limitations; and providing decision options to the Secretary to help him assess the role of national defense in the formulation of national security policy and related decisions”⁸

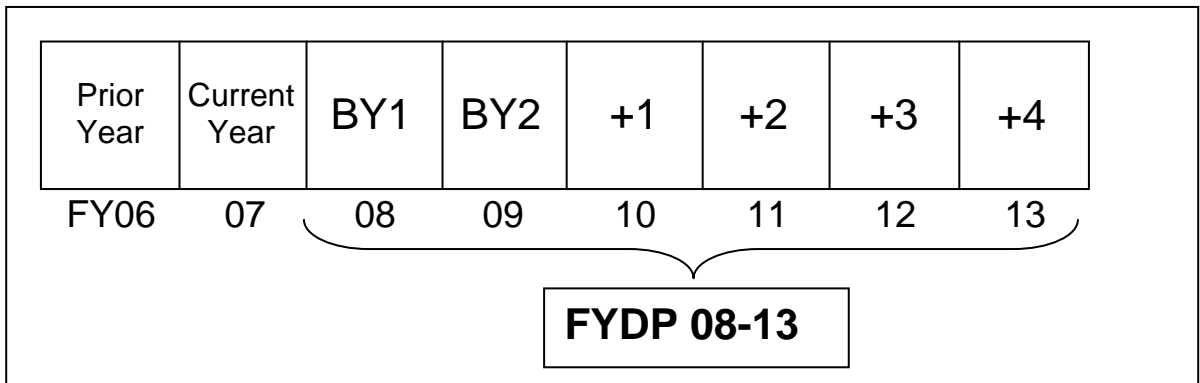

Figure 2.3: Future Years Defense Program

The FYDP for the FY 2008 budget year, due with the President’s Budget by the first Monday in February 2007, records resource totals for:

- The Past Year, FY 2006
- The Current (or Execution) Year, FY 2007
- The Budget Years, FY 2008 and 2009
- Four Years beyond the Budget Years, 2010 through 2013

The TPG describes the near-term as 2-7 years out, covering the FYDP; the mid-term as just beyond the FYDP; and the far-term as 15-20 years out. Joint operational planning focuses on “existing” capabilities available for employment during the period of time for which the plans are effective. In the Analytic Agenda, current forces are defined as forces in existence in the current fiscal year (the execution year) or planned to be available in the first year of the FYDP. Future forces are defined as forces projected to be available beyond the first year of the FYDP.⁹ In JCIDS, concepts of operations (CONOPS) are written to describe how a joint force commander may organize and employ forces in the near-term (now through 7 years into the future) in order to solve a current or emerging military problem. The “family” of joint concepts covers a period beyond the FYDP, 8-20 years in the future.¹⁰ The SecDef-approved DPSs are written at 8 and 20 years into the future. The Joint Warfighting Science and Technology Plan (JWSTP) has a horizon less than 5 years, the Defense Technology Area Plan (DTAP) a horizon of 5-20 years, and the Basic Research Plan (BRP) a horizon of 20-25 years.

Prerequisites for implementing CBP should be establishing consistent meanings for current, near-term, mid-term, and far-term to align analytic procedures, and clarifying the horizons for strategic guidance. Because this involves all capabilities development

planning processes, this is an issue for resolution among the OSD Principal Staff Assistants and counterparts on the Joint Staff and COCOM and Service staffs.

2. Are the capabilities that are or will be available adequate and balanced?

Having identified the key missions required of the force and the time frames for their execution, DoD's planning system must next determine whether the capabilities that are expected to be available are adequate to accomplish those required missions. In this context, "adequacy" encompasses both the proficiency and sufficiency of the available capabilities. The QDR Force Planning Construct provides a basis for assessing the sufficiency of forces. Assessing proficiency demands a detailed understanding of the concepts for using the force and what each element of the force will be expected to do.

Determining adequacy over time presents a major challenge for CBP. The intention is to implement a "balanced scorecard" to manage risks by *balancing* resource allocation between current "Operations/Force Employment," and "Future Challenges/Force Development," and among these and "Force Management" and "Institutional" activities, over time.¹¹ The major efforts to date in CBP have been in "Future Challenges/Force Development" (referred to in this paper as capabilities development planning). Today, balancing current and future risk is difficult, but promising methods and tools to support senior leader decisions are under development. The processes for understanding force management and institutional resources associated with alternative force structures and postures do not yet exist. To balance all DoD resources, processes must be developed to relate capabilities to (1) program elements (for planning, programming and budgeting); (2) military tasks (the basis for training plans and readiness assessments); (3) operational units (for Global Force Management and to capture non-procurement resources associated with operational units); and (4) the resources associated with DoD elements other than operational forces. The first three are challenging, but OSD Principal Staff Assistants, the Joint Staff, and the COCOMs have been developing various methods to map these relationships. Since the preponderance of non-operational institutional resources have no direct relationship to operational units, this area is the most challenging for CBP. The result is that CBP decisions currently address predominantly Procurement and Research, Development, Test and Evaluation (RDT&E) accounts (less the Science and Technology part of RDT&E) that represent about 34 percent of DoD's budget.

Holistic "Mission" Analyses

Balancing resource allocation requires holistic analyses that compare force capabilities to the missions for which strategic guidance has directed commanders to prepare.

To do this, each of the Services has developed its own capabilities development planning processes:

Army: Army Force Development Process

Air Force: Capabilities Review and Risk Assessment

Navy: Navy Capabilities Development Process

Marine Corps: Expeditionary Force Development Process

In translating strategic guidance for force employment planning into Operations/Contingency, Joint Training, Theater Security Cooperation Plans, and joint combat development plans, the COCOM commanders conduct mission analyses that identify what capabilities they need to perform assigned responsibilities. Combat Support Agencies (CSAs) have similar planning processes. These analyses have in common processes that:

- identify and prioritize effects (objectives) required to fulfill assigned responsibilities and accomplish assigned missions and tasks;
- identify and prioritize the capabilities needed to achieve those effects (using the Joint Capability Area taxonomy as directed by the SecDef, though not all Services and CSAs have yet implemented this direction);
- identify and prioritize capability gaps, sufficiencies, excesses, redundancies, and areas to accept risk (some analyses only identify gaps);
- suggest strategies (programmatic and other) to mitigate gaps.

Several processes exist that contribute to assessing the adequacy and balance of current and near-term forces. These include:

- COCOM mission analyses
- CJCS Analytical Baseline for Current Forces
- Chairman's Risk Assessment
- Global Sourcing Risk Assessments
- Joint Quarterly Readiness Reports (JQRs)

COCOM mission analyses focus upon current and near-term challenges, capabilities, forces, and technical opportunities (though Theater Security Cooperation and force basing and posture plans have long time horizons). The Analytical Baseline for Current Forces is one component of the Analytic Agenda, led by the CJCS. Congress requires the Chairman in odd-numbered years to submit to the SecDef a report providing the Chairman's assessment of the nature and magnitude of the strategic and military risks associated with executing the missions called for under the current National Military Strategy.¹² The Chairman's Risk Assessment fulfills this requirement. Global Force Management Guidance includes direction to assess operational, future, institutional, and force management risks involved in the assignment and allocation of forces. US Joint Forces Command (USJFCOM), as the primary Joint Force Provider, assesses the risks associated with a particular recommendation and the CJCS conducts a strategic risk assessment and develops risk mitigation options with USJFCOM, the affected COCOMs, and Military Departments.¹³ Joint readiness is assessed against the COCOMs' ability to integrate and synchronize forces to meet military objectives. The primary tool for reporting joint readiness is the JQRR, which provides the Chairman a current and broad assessment of the joint force's ability to execute strategic guidance.

A different set of analyses focuses on assessing the adequacy of mid- and far-term capabilities. Service developed and directed force development processes provide partial information on the adequacy and balance of forces in these time frames. The focus of

Service and CSA analysis is (1) construction of their Program Objective Memoranda (POMs) over the near- to mid-term; and (2) far-term challenges, technology developments, and program projections to inform the development of their force structures. The Analytic Agenda and Operational Availability studies (discussed in Chapter 4 and Appendix C) entail shared responsibilities among OSD, the Joint Staff, and FCBs. JCIDS CBAs address the adequacy of force capabilities for selected missions. Joint CBAs are similar to those of the Services, but from a DoD and joint perspective. As currently conducted they do not provide holistic analyses of the entire force.

Two significant challenges in conducting holistic analyses are (1) clear identification of the forces used in the analyses, and (2) the scenarios and concepts used for mid- and far-term analyses. With the recent implementation of Global Force Management, the forces apportioned to COCOMs for planning have become less clear. Understanding the sufficiency of forces to execute the force planning construct requires an ability to identify clearly which forces are called for in which plans as a basis for determining the sufficiency of force capabilities. With the implementation of Adaptive Planning, which calls for the identification of alternative forces to provide similar capabilities, understanding what forces formed the foundation for capability assessments will become even more important. Thus, another prerequisite for implementing CBP is establishing business rules for what forces (which years and what units or force elements) planners use for establishing capability gaps, sufficiencies, and excesses.¹⁴ For example, the Multi-Service Force Deployment (MSFD) documents generated by the Analytic Agenda should employ business rules consistent with those used by COCOM planners.

Issues involved with scenarios and concepts are addressed in the context of the Analytic Agenda and JCD&E in Chapter 4.

3. What are the priority issues requiring greater effort?

A consistent theme of CBP is the need to focus Pentagon processes upon outputs (fielded capabilities) rather than inputs (budgets and programs). When conducting combat operations, gaps in fielded capabilities are apparent. For future risks, focusing leadership and management attention upon outputs requires establishing priorities early in planning processes.

For current and near-term forces, each of the Services and US Special Operations Command (USSOCOM) (with Major Force Program 11 funds) has established procedures for addressing urgent warfighter needs. A Joint Urgent Operational Need (JUON) is a need:

identified by a combatant commander involved in an ongoing named operation. A JUON's main purpose is to identify and subsequently gain Joint Staff validation and resourcing of a solution, usually within days or weeks, to meet a specific high-priority combatant commander need. The scope of a combatant commander JUON is limited to addressing urgent operational needs that: (1) fall outside of the established Service [and USSOCOM] processes; and (2) most importantly, if not addressed immediately, will seriously endanger personnel or pose a major threat to ongoing operations. They should not involve the development of a new technology or capability; however, the acceleration of an Advanced Concept Technology Demonstration or minor modification of an existing system to adapt to

a new or similar mission is within the scope of the JUON validation and resourcing process.¹⁵

Immediate Warfighter Needs are a subset of JUONs requiring fielding within 120 days. A Joint Rapid Acquisition Cell (JRAC) has been established to facilitate this rapid fielding. Supplemental budgets for ongoing operations provide the funds supporting this activity. Whether these procedures will persist in the absence of supplemental funding is not clear.

COCOM IPLs principally address capability gaps identified through COCOM mission analyses which address current and near-term forces. JCIDS CBAs are tasked with prioritizing near-, mid-, and far-term capability gaps within the domain of the assessment.

As previously mentioned, the JWSTP provides science and technology priorities for a five-year time horizon, the DTAP provides priorities for the 5-20 year time frame, and the BRP has priorities for 20-25 years in the future.

Development of and experimentation on strategic and operational concepts (such as that historically conducted on War Plan Orange for the war against Japan, for the Maritime Strategy and Air-Land Battle in the 1980s, and more recently Rapid Decisive Operations and the JOpsC family of future joint concepts) provide insights on areas where the Services and DoD need to place more emphasis to achieve desired future capabilities.

For investment in future capabilities, QDRs and SPGs specify priority areas for study. Recently, the Joint Staff has initiated a “focusing construct” to provide priorities and guidance for the day-to-day activities of capabilities development planning processes. This initiative was motivated by JROC concerns that they were not spending their limited time on the most important issues facing the Department.

This process (Figure 2.4) integrates inputs from OSD, the Joint Staff, COCOMs, Services and CSAs, and USJFCOM (for transformational issues and joint experimentation) to formulate a set of Most Pressing Military Issues (MPMI) that the JROC provides to guide the activities of the Services, FCBs, and other agencies. One criticism of the JCIDS process is that it has been more focused on implementing new processes than on outputs. The JCIDS workload had been driven by program proposals as they arrived from sponsors (principally Services).

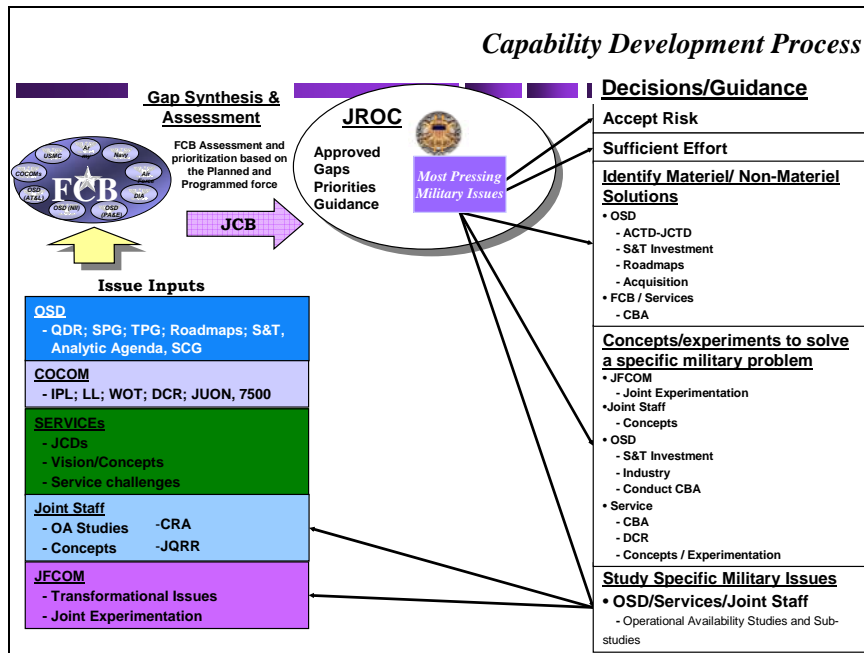

Figure 2.4: Most Pressing Military Issue Identification¹⁶

Setting priorities and focusing the efforts of the FCBs on those priorities will make the system more oriented to producing the capabilities of greatest value, rather than exhausting staffs upon what first arrived in the in-box.

4. What are the priority capability gaps within these issues?

JUONs, COCOM IPLs, and the MPMI identify the most important *problems to study*. In the case of JUONs and COCOM IPLs, they also identify the *problems to solve* in the immediate and near term. The MPMIs are intended to lead to tasking more detailed capability assessments that identify the *problems to solve* in addressing these issues over the near, mid, and far-term.

Current JCIDS CBAs have focused on this level of analysis for topics such as Joint Undersea Superiority, Joint Forcible Entry Operations, and Global Strike. What are currently called Functional Area Assessments (FAAs) and Functional Needs Assessments (FNAs) identify prioritized gaps in capability to perform the intended *mission* over time, which are documented in Joint Capability Documents (JCDs). JCDs offer mitigating strategies that include materiel and non-materiel (including policy) approaches.

Note that these so-called FAAs and FNAs are misnamed. These analyses are mission or capability area and needs analyses, narrowly focused on specific missions and tasks. They address only small subsets of the functional areas assigned to FCBs, and do not provide the broad functional assessments needed to compare the full suite of tasks that must be performed within a functional area to existing and programmed capabilities – the sort of broad, holistic assessment needed to identify redundancies or excesses as well as gaps. As mentioned earlier, the identification of “offsets” is an important activity if CBP is to inform programming trade-offs.

Scenarios and CONOPs are inputs to capability analyses. They provide the context needed to establish standards and conditions against which to compare current and programmed force capabilities. In conducting the capability needs analyses, promising new CONOPs may affect future needs. Normally, some level of joint concept development and experimentation (JCD&E) will be needed to explore the feasibility of the new CONOPs and distinguish between more and less promising alternatives. Therefore, JCD&E at an operational-tactical level (such as that conducted for Air Craft Carrier, Amphibious Operations, and Underway Logistics in the interwar years, or Follow-on Forces Attack and Operational Maneuver from the Sea more recently) informs the understanding and refinement of capability needs.

Because initial decisions regarding investments must be made before the evidence from JCD&E can be garnered, the development and refinement of capability needs for important mission area must involve spiral processes. This is just one example of the importance of a battle-rhythm for CBP that fosters learning through feedback and refinement of capabilities consistent with change in the strategic and operational challenges and the pace of technological advances. As DoD makes progress in addressing priority capability gaps within issues, both the priority gaps and the MPMIs should change.

5. How should the priority capability gaps be addressed?

Solution analyses call for a third level of detail that gets down to the level of Key Performance Parameters (KPPs) for the development and testing of new capabilities. This is the level where capability needs (both materiel and non-materiel) are translated into programs.

Immediate Warfighter Needs and JUONs rely upon available technology to support prompt fielding and therefore have conducted solution analyses as part of their input. COCOM IPLs also often include proposed solutions for near-term mitigation of capability gaps.

The proposed Concept Decision process described in Chapter 1 provides a new approach to solution analyses in implementing CBP. It addresses a difficulty with the current approach to solution analyses where a single sponsor (defined as having acquisition authority) colors the solution alternatives that are considered. In seeking to stabilize the funding for programs, it rolls together consideration of detailed solution alternatives from multiple sponsors, consideration of cost-performance-schedule trades, and consideration of technological risks. The intent is to support Time-Defined-Acquisition of capabilities that would deliver capabilities in 0-2 years for low-risk capabilities (presumably extending early delivery beyond the criteria now used for JUONs), 2-4 years for limited-risk capabilities, and greater than 4 years for capabilities that require current approaches to reduce risk. The intent is to manage capability portfolios that would facilitate allocating resources to specific programs as the capability needs and technological progress became clearer. DoD is experimenting with this new approach over the later months in 2006, and intends to provide implementing instructions based upon that experience.

To the extent that Time-Defined-Acquisition is focused upon mitigating capability gaps, as opposed to accelerating acquisition programs, a JCD&E process that uses experimental articles (prototypes without a commitment to a program) to bring together

users and developers for concept refinement will be critical. Getting experimental articles into the hands of warfighters more quickly makes it easier to identify the requirements for new systems (reducing the costs incurred when warfighters press design changes following system development), and allows concurrent development of doctrine and training materials. Here a third level of JCD&E explores and experiments with possible DOTMLPF solutions to priority capability gaps, and contributes to transitioning successful experiments rapidly to deploying units.

The Concept Decision process – requiring decisions by the VCJCS, USD(AT&L) and Director, PA&E – should be reserved for MPMIs, Acquisition Category I (ACAT I) programs, below-threshold programs designated as of special DAB interest by the USD(AT&L), and other programs designated JROC Interest by the JCIDS Gatekeeper. Other sponsor program proposals could be processed using “Functional Solution Analyses” and “Analyses of Alternatives” as specified in current CJCS JCIDS and DoD Acquisition instructions.¹⁷

6. What programs can be decremented to fund higher priority capability gaps?

Identifying candidates for programs to decrement to free funds for higher priorities requires holistic analyses of all capabilities related to the range of missions identified in strategic guidance and identification of the low as well as high priority capabilities and missions. Low priorities could include excess or redundant capabilities and lower priority sufficiencies in capability, as well any effects (objectives) which, if not accomplished, would not significantly jeopardize an organization’s ability to perform its responsibilities. More sophisticated criteria may be adopted. However, if only gaps are identified, there is no basis for identification of “offsets.” The absence of offsets has significantly limited the ability of the Department to address emerging priorities. This is an essential activity if resource allocation decisions are to be made coherently as part of the Department’s mainstream management system, and not just at the eleventh hour by the budgeting community without full consideration of the implications.

Though the Services and USSOCOM have processes for addressing program offsets in building their POMs, OSD, the Joint Staff, and COCOMs have no similarly comprehensive trade-off processes to identify offsets to fund priority joint capability gaps. The JRAC oversees the use of supplemental funding for Immediate Warfighter Needs. The Joint Staff oversees the use of supplemental and other funding for other JUONs. The Aldridge study intended processes supporting the preparation of the JPG to perform this function. However, the JPG to date (informed by the Chairman’s Program Recommendations – CPR) has resulted in moving only hundredths of a percent of the DoD budget, orders of magnitude less than envisioned in the Aldridge Report, due to the need to remain resource neutral. This has resulted in Program Decision Memoranda (PDMs) and Program Budget Decisions (PBDs) continuing to produce the “December trainwreck” that causes major revisions in the Service and Agency POMs with limited analysis of the consequences.

7. What affordable mix of programs will provide the sufficient capability at acceptable risk?

The answer to this question is similar to that for the previous question. Absent holistic prioritization of capability gaps, sufficiencies, and excesses and a process for identifying offsets for higher priority capability gaps, the current PPBE processes address only one program at a time. The Concept Decision is intended to improve this by creating portfolios of programs, but will not clearly address trades among portfolios.

8. Is the system executing the decisions that were made?

Title 10 specifies that the Chairman, supported by the JROC, monitor program execution against criteria such as COCOM IPLs and national security strategy. The CRA addresses risks inherent in current and near-term plans. The CPR and CPA (both private documents from the Chairman to the Secretary) are mechanisms for reporting on the execution of leadership decisions.

The Aldridge Study emphasized an execution and accountability phase to DoD joint capability development. This portion of the Aldridge Study was addressed in a December 9, 2003 implementing memorandum directing feedback on the first cycle of implementation of the new system.¹⁸ However, this did not result in the implementation of a continuing or robust evaluation process.

Summary

Table 2.2 provides a summary of the questions forming the analytical framework for CBP implementation together with the existing mechanisms and processes available to joint decision makers for answering these questions over different planning horizons. As the preceding discussion demonstrates, while many processes exist to address these needs, much work remains across the DoD leadership to implement even the capability development planning portions of CBP focused on the mid- and far-term future time frames.

Question	CBP Functions	Immediate Answer*	Near-Term Answer*	Mid-Term Answer*	Far-Term Answer*
1. What do military forces need to be prepared to do? When?	Force Employment Planning & Capability Development Planning Guidance	<ul style="list-style-type: none"> NSS, NDS, NMS Touchstones UCP, CPG, SCG, JSCP OPLANs, CONPLANs, etc 	<ul style="list-style-type: none"> NSS, NDS, NMS Touchstones SPG UCP, CPG, SCG, SCG, JSCP, National Military Strategic Plans (WOT, Cyber, etc) 	<ul style="list-style-type: none"> NSS, NDS, NMS Touchstones SPG Mid-term DPSs 	<ul style="list-style-type: none"> Long-term DPSs
2. Are the capabilities that will be available adequate and balanced?	Holistic "Mission" Analyses	<ul style="list-style-type: none"> COCOM mission analyses CJCS Current Year Analytic Baseline Chairman's Risk Assessment Global Sourcing Risk Assessments JQQR 	<ul style="list-style-type: none"> COCOM mission analyses CJCS Current Year Analytic Baseline Chairman's Risk Assessment JCIDS CBAs 	<ul style="list-style-type: none"> Operational Availability (OA) or other Analytic Agenda studies Service force development studies JCIDS CBAs 	<ul style="list-style-type: none"> Service force development studies JCIDS CBAs
3. What are the priority issues requiring greater effort?	Most Pressing Issue Identification: Problems to be Studied	<ul style="list-style-type: none"> Immediate Warfighter Needs JUONs 	<ul style="list-style-type: none"> COCOM IPLs JCIDS CBAs FCB/JROC Most Pressing Military Issue (new informal process) Joint Warfighting S&T Plan 	<ul style="list-style-type: none"> JCIDS CBAs FCB/JROC Most Pressing Military Issue (new informal process) Defense Technology Area Plan 	<ul style="list-style-type: none"> JCIDS CBAs JCD&E Defense Technology Area Plan Basic Research Plan
(* clarifying boundaries between time frames is a prerequisite for CBP)					

Table 2.2: Capabilities-Based Planning Questions . . . and Where Joint Decision-Makers Can Look for Answers

Question	CBP Functions	Immediate Answer*	Near-Term Answer*	Mid-Term Answer*	Far-Term Answer*
4. What are the priority capability gaps within these issues?	Capability Assessments: Problems to be Solved	<ul style="list-style-type: none"> Immediate Warfighter Needs JUONs 	<ul style="list-style-type: none"> JUONs COCOM IPLs JCIDS CBAs JCD&E 	<ul style="list-style-type: none"> JCIDS CBAs JCD&E 	<ul style="list-style-type: none"> JCIDS CBAs JCD&E
5. How should the priority capability gaps be addressed?	Solution Analyses: Concept Decision	<ul style="list-style-type: none"> Immediate Warfighter Needs JUONs 	<ul style="list-style-type: none"> JUONs COCOM IPLs Concept Decision JCD&E 	<ul style="list-style-type: none"> Concept Decision JCD&E 	<ul style="list-style-type: none"> Concept Decision JCD&E
6. What programs can be decremented to fund higher-priority capability gaps?	Trade-off Analyses	<ul style="list-style-type: none"> JRAC 	<ul style="list-style-type: none"> JUON Staffing JPG PDMs/PBDs Concept Decision 	<ul style="list-style-type: none"> JPG PDMs/PBDs Concept Decision 	<ul style="list-style-type: none"> Concept Decision
7. What affordable mix of programs will provide sufficient capability at acceptable risk?	Resource Allocation and Reallocation for Joint Priorities	<ul style="list-style-type: none"> CRA 	<ul style="list-style-type: none"> Program Review CPA 	<ul style="list-style-type: none"> Program Review CPA 	<ul style="list-style-type: none"> Program Review
8. Is the system executing the decisions that were made?	Execution Monitoring	<ul style="list-style-type: none"> CRA 	<ul style="list-style-type: none"> CPR/CPA 	<ul style="list-style-type: none"> CPR/CPA 	<ul style="list-style-type: none"> CPR/CPA

(* clarifying boundaries between time frames is a prerequisite for CBP)

Table 2.2 (cont'd): Capabilities-Based Planning Questions . . . and Where Joint Decision-Makers Can Look for Answers

End Notes

¹ For a recent illustration of these continuing trends Honorable E.C. Aldridge, et al., Joint Defense Capabilities Study: Improving DoD Strategic Planning, Resourcing and Execution to Satisfy Joint Capabilities, Final Report, January 2004, p. 1-1.

² The 2001 QDR led the Department to direct the military to organize, train and equip sufficient forces to defend the U.S. homeland; operate in and from four forward regions; “swiftly defeat” adversaries in two overlapping military campaigns while preserving for the President the option to “win decisively” one of those campaigns; and conduct a limited number of lesser military and humanitarian contingencies. This is commonly referred to as the 1-4-2-1 force planning construct. In the 2006 QDR, DoD refined its Force Planning Construct, dividing its activities into three objective areas: Homeland Defense, War on Terror/Irregular (Asymmetric) Warfare, and Conventional Campaigns, with steady-state and surge requirements in each category. Quadrennial Defense Review Report, February 6, 2006.

³ Composite of slides from DoD News Briefing, Friday, 03 Feb 2006 – 1:00 PM. Accessed 29 August 2006 at the Defense Link website, <http://www.defenselink.mil/news/BriefingSlide.aspx?BriefingSlideID=17>

⁴ Secretary of Defense, “Adaptive Planning Roadmap,” November 2005.

⁵ CJCSI 3100.01A, Joint Strategic Planning System, September 1, 1999 (certified current as of September 12, 2003).

⁶ Over the past couple of years, CJCS has been developing and promulgating National Military Strategic Plans providing additional guidance for the war on terrorism, combating weapons of mass destruction, and cyberspace operations.

⁷ DoDI 7045.7, “Implementation of the Planning, Programming, and Budgeting System (PPBS)” May 23, 1984 (with Change 1, April 9, 1987. See also DoDD 7045.14 “The Planning, Programming and Budgeting System (PPBS),” May 22, 1984, Certified current as of November 21, 2003, and DoD 7045.7-H, “FYDP Program Structure Handbook,” June 2003.

⁸ Ibid, paragraph 5.3.2.

⁹ DoDD 8260.2, Data Collection, Development, and Management in Support of Strategic Analyses, December 6, 2002, and DoDI 8260.2, Implementation of Data Collection, Development, and Management in Support of Strategic Analyses, January 21, 2003.

¹⁰ CJCSI 3010.02B, Joint Operations Concepts Development Process (JOPSC-DP), January 27, 2006, and Series 3170 JCIDS directives.

¹¹ The risk management framework was introduced in the 2001 QDR, but the terms have since been refined. The terms in quotes are referenced from the “QDR Execution Roadmap, Institutional Reform and Governance, Capability-Based Force Development Concept Brief (Continued),” unpublished briefing, February 28, 2006.

¹² Title 10, United States Code, Section 153(b)

¹³ The guidance neither defines the risks nor provides any procedures for assessing them. “Global Force Management Guidance FY 2005 (U),” signed May 4, 2005 by SecDef.

¹⁴ Which units are apportioned may be important if there are differences in capabilities between units (e.g. one is more modernized). Where the unit is located is also important, because that drives closure times, which drives CONOPS.

¹⁵ CJCSI 3470.01, Rapid Validation and Resourcing of Joint Urgent Operational Needs (JUONs) in the Year of Execution, July 15, 2005.

¹⁶ LTC Boyd Bankston and LTC Todd Key, “White Paper on Capabilities-Based Planning,” March 30, 2006, p. 12. Available at http://www.mors.org/meetings/cbp_II/briefs/bankston_key.pdf,

¹⁷ CJCSI 3170 and DoD 5000 series.

¹⁸ Memorandum from Ryan Henry, Ken Krieg, LtGen Cartwright, “Enhanced Planning Process Procedures for FY 2006-11,” December 9, 2003.

Chapter 3: Alignment of Planning Processes and Key Decisions

Capabilities development planning activities in DoD can broadly be described as a combination of major decisions and processes that support those major decisions. This chapter:

- identifies the most important capabilities development planning processes and decision points;
- assesses the current alignment of these processes and decision points, in terms of both substance and timing;
- presents options for improving alignment of these processes and decision points.

Options offered in this chapter are focused on, though not exclusively limited to, actions and authorities available to the CJCS.

Overview of Major Planning Processes and Decision Points

Figure 3.1 presents a graphical distillation of the most important capabilities development planning processes and decision points in relationship to a typical annual schedule, as they are currently aligned. Periodic decision events and documents or relatively short discrete processes are depicted as small rectangles, and ongoing processes are depicted as elongated rectangles spanning the entire year. Arrows linking the boxes represent input and output relationships between those boxes.

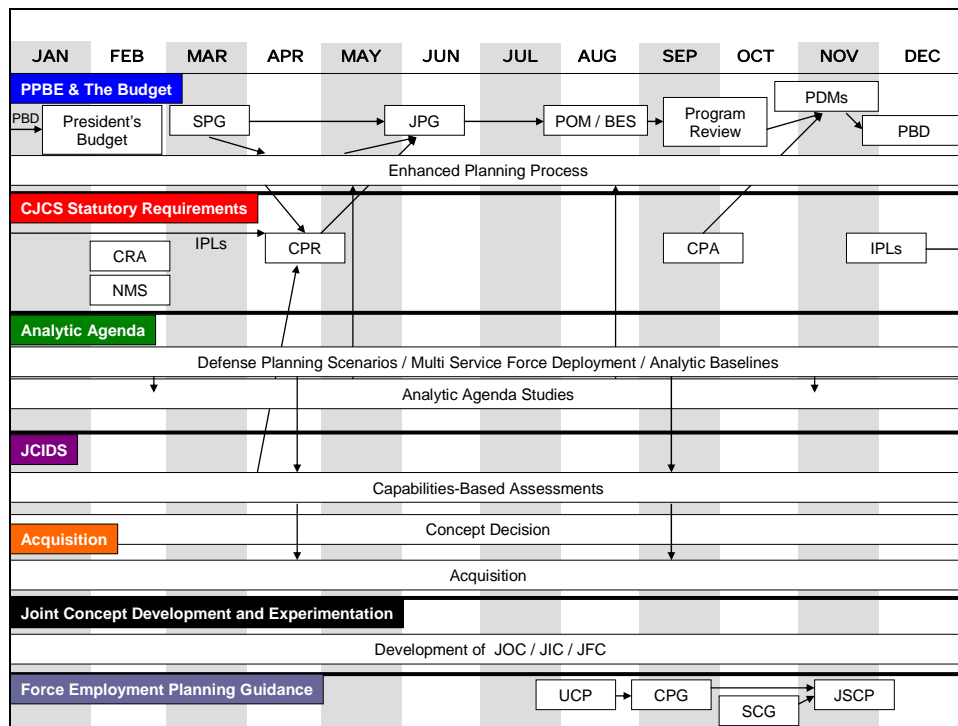

Figure 3.1: Major Planning Processes and Decision Points – an “As Is” Non-QDR On Year

The category headings in Figure 3.1 correspond to the processes identified in Chapter 1, with two exceptions: a new category heading (“CJCS Statutory Requirements”) that cuts across processes is added, and strategic guidance processes are shown as being split between the new category heading and “PPBE & the Budget.” Force employment planning guidance documents are listed at the bottom of the figure principally as a reminder that they are also in development and execution at the same time as the other capabilities development planning processes and decisions. Their placement on the calendar does not correspond to the actual publication of these documents.

It is important to note that Figure 3.1 depicts only one year of the two-year PPBE cycle instituted in 2003 by MID 913, and it does not reflect the potential impact of a QDR on planning processes. The year depicted is a non-QDR “on year” in the biennial budget cycle. This is assumed to be the best representation of the basic PPBE framework. Applications of the following descriptions and options to “off years” and QDR years can be fairly readily addressed as modifications to the basic process outlined here. Also, given the timing of this study’s completion, the first opportunity to test any of the options offered here would likely be in preparation for the budget cycle occurring in Calendar Year (CY) 2008 (in preparation of the FY 2010-15 FYDP); and CY2008 is a non-QDR on year – the kind depicted here as a baseline representation of the capabilities development planning processes and decisions.

Even this simplified depiction demonstrates a complex network of process interactions and decision points. However, for major resource allocation decisions beyond the execution year, most major decisions on planning guidance, programs, and budgets must pass through at least one of four points:

- Strategic Planning Guidance (SPG)
- Joint Programming Guidance (JPG)
- Program Decision Memoranda (PDM)
- Concept Decision (CD)

(Note that the last of these, the CD, is a newly established process that straddles the boundary between JCIDS and Acquisition activities, as depicted in the figure. Though Concept Decisions are driven by the rhythm of Acquisition rather than the budget submission, the process is included here because of its importance as an explicit decision requiring supporting analysis and staffing for both the VCJCS and OSD Principal Staff Assistants.)

Notable by their absence from this list are three major strategy documents: the National Security Strategy (NSS), the National Defense Strategy (NDS), and the QDR (see Appendix B for descriptions). The first two are not included on this list for two important reasons. First, the NSS and NDS are not issued on a regular schedule (congressional direction notwithstanding). Their irregularity makes them difficult to incorporate into cyclical planning processes, beyond ensuring that more regular planning guidance documents, such as the SPG, are compliant with the most current versions. Second, and more important, while the NSS and NDS provide important articulations of broad strategic objectives and of US declaratory policy, they generally do not provide sufficient detail to serve as a basis for choosing among alternative military capability options. They are

public documents, and policy makers understandably limit the extent to which detailed strategies and statements of risk tolerance are accessible to potential adversaries.

The QDR, though it has contained at least some guidance that is specific enough for guiding choices among capability alternatives, is inhibited in similar ways as the NSS and NSS by virtue of being a public document. Moreover, since QDR reports are now aligned to be submitted to Congress in budget on years when an SPG is also issued, the classified SPG is assumed to be the more authoritative of the two documents for driving capabilities development. SPGs issued together with a QDR report should reflect all of the strategic and planning guidance issued in the QDR, as well as more specific and classified guidance.

Recognizing, then, that the four decision points listed above together represent separate culminations of the Department's major joint capabilities development planning processes, it follows that joint decision support activities should be structured around these points. And if these decision points are to provide the main anchors for aligning decision support processes, then we must start by understanding clearly the purpose and scope of each of these points.

Purpose of the SPG (from the Aldridge Study)¹

- Establish strategic objectives and priorities
- Identify fiscal and other planning constraints
- Articulate priorities and risk tolerance
- Establish joint capability objectives
- Identify strategic concepts for planning future enterprise functions
- Identify future joint operational and organizing concepts

Purpose of the JPG (from the Aldridge Study)²

- Address the totality of the defense budget
- Communicate specific programmatic actions on issues of concern to the SecDef and the joint capability resourcing needs stemming from the EPP
- Comply with the SPG
- Provide directive guidance on selected joint capability issues
- Identify programmatic elements that are delegated to the components
- Ensure fiscal adequacy

Purpose of the PDMs (from USD(Comptroller) documentation)³

- Formally document the directives from the Secretary and Deputy Secretary of Defense to the Components on issues raised during the POM review
- Conclude the programming phase of PPBE

Purpose of the CD (from USD(AT&L) congressional testimony)⁴

- Improve stability of acquisition programs, requirements, and funding
- Enable early tradeoffs and solution optimization prior to the point of significant commitment to future investment

The remainder of this chapter proceeds from the premise that the Chairman should have robust processes for generating military advice that is timed to inform and influence these major Departmental decisions, in terms of both timing and scope. Accordingly, the question that motivates the ensuing discussion is: how can the Chairman best influence these decision points? The starting point for answering this question is a consideration of the Chairman's most important existing statutory mechanisms for providing guidance and advice on capabilities development planning. Those mechanisms, as shown in Figure 3.1, are the NMS, the CRA, the CPR, the CPA, and the Annual Report on Combatant Command Requirements (ARCCR). (The ARCCR is represented in the figure by the IPLs, which are aggregated to form the ARCCR.). The recent histories of some of these documents are described in Appendix B. Also, for definitions and statutory references for these reports, see Appendix G.

Strategic Planning Guidance

The first of the four key decision points is the SPG. Despite the SPG's status as the Department's main vehicle for linking strategic objectives to capabilities development planning, the Chairman has no formal mechanism to provide integrated input into the SPG. Input is provided informally, through senior leader fora such as the Defense Senior Leader Council (DSLCC) and the Deputy's Advisory Working Group (DAWG), and through interactions at lower levels in the organization, such as Joint Staff participation in OSD-Joint Staff working groups and Integrated Product Teams (IPTs). While the Chairman is able to and does provide significant input into the development of the SPG, this input does not stem from an integrated analytic review that would focus and prioritize the Chairman's advice on topics such as:

- Priority capability gaps
- Planning assumptions
- Global Defense Posture
- Adaptive Planning
- Global Force Management
- EPP focus areas
- Recommendations for DPSs
- Recommendations for Operational Availability (OA) series of studies and other joint analytic priorities
- Strategic and operational risk assessments
- Policy guidance to improve DoD enterprise effectiveness

The following options represent a few alternative approaches for addressing the Chairman's input into the SPG.

Option 3-A: Revitalize Joint Planning Document (JPD)

Description: Re-establish the JPD, which was a mechanism prescribed by the Joint Strategic Planning System (JSPS) for providing formal CJCS input to the DPG. Joint Staff Directorate for Strategic Plans and Policy (J-5) would lead this effort with J-8 programmatic and other analytical support.

Pros: Provides Chairman with a dedicated mechanism for assembling and formally transmitting advice on SPG; JPD could also serve as guidance for Joint Staff activities throughout PPBE; process of developing JPD would likely have unifying effect.

Cons: Increases workload for document coordination and management.

Option 3-B: Align existing documents with SPG development timing.

Description: Use the NMS, the CRA and the ARCCR to support formal input to the SPG (in budget on years). Joint Staff J-5 would lead this effort with J-8 programmatic and other analytical support.

Pros: Avoids further proliferation of documents requiring coordination, management; risk assessment and COCOM requirements are well-suited to the type of input needed for SPG.

Cons: May require legislation to modify current statutory deadlines.

As noted in these options, the benefits of formalizing CJCS input to the SPG extend beyond improving the quality of that input. Formalization would also assist Joint Staff action officers in conducting their daily work. While formal military advice is presented at the top, from the Chairman to the Secretary of Defense and the President, advice is also regularly presented at lower levels as Joint Staff officers meet and collaborate with their OSD counterparts. If Joint Staff officers do not know the Chairman's priorities, by the time an integrated staff product such as the SPG works its way through staff layers for the Secretary's approval, it may not be what the CJCS had in mind. Guidance down the Joint Staff chain is no less important than advice to the Secretary.

Joint Programming Guidance

The next key decision point is the JPG. The Chairman currently provides input to the JPG through the CPR, which is developed based on input from the COCOM commanders and from other Joint Staff analyses, such as assessments conducted under JCIDS. The CPR seems to be an adequate mechanism for influencing the JPG, but the varied timing and lack of coordination of the various inputs to the CPR hamper efforts to translate strategic guidance, military advice, and analytic results into integrated programmatic recommendations. In particular, no structured process exists for assessing and recommending trade-offs.

The following option suggests a method to address this weakness of the current CPR development process.

Option 3-C: Create decision support mechanism for building CPR.

Description: Joint Staff assembles Service and COCOM inputs on capabilities and programs and integrates them to create the CPR.

Pros: Helps generate high-quality, integrated programmatic recommendations; could introduce structured process for recommending trade-offs.

Cons: Requires significant process changes and possibly additional resources.

Program Decision Memoranda

The third key decision point is the culmination of the programming phase of the budget cycle: the creation of PDMs. The Chairman currently provides input to the Program Review and Program Decision Memoranda through the CPA, which is developed based on comparisons of POMs with recommendations made earlier in the CPR. While the closely-held nature of the CPA makes assessment of the current process difficult, the following options suggest ways of addressing its alignment with the key decision points it is meant to inform.

Option 3-D: Treat CPA principally as an audit mechanism.

Description: CPA focuses on its statutory role of advising the Secretary on compliance of POMs with strategic plans and requirements.

Pros: Less demanding decision support requirements; consistent with statutory purpose.

Cons: Insights and changes emerging after CPR may go unaddressed.

Option 3-E: Use CPA to advance new recommendations.

Description: In addition to its audit role, CPA provides another opportunity to provide input based on insights and changes that have emerged since the CPR.

Pros: Could enhance responsiveness of resource allocation process.

Cons: Too late in the cycle to conduct any systematic review of new recommendations, options, etc.

Concept Decision

The fourth key decision point is the Concept Decision, but this is distinct from the other three in that Concept Decisions are not tied to a particular budget deadline and are instead dictated by leadership interest in particular capabilities. For this reason, this decision “point” will be addressed later, in Chapter 4.

Whether or not these or other options are pursued, aligning the Chairman’s input on capabilities development planning with the Department’s major decision points has some relatively specific implications for the timing of generating that input. Figure 3.2 below presents a simple method for tracing those timing implications. The first point to note on the table is that the assumed release date for the SPG is December. This is consistent with the original guidance from the Secretary directing the establishment of the SPG.⁵ It is not consistent, however, with the actual release dates of the two SPGs produced to date, both of which were published in March (as reflected in Figure 3.1). The basis for using the

intended release date rather than the historical release date as a planning factor is simply that relaxing deadlines that are discovered to be unnecessarily early is inherently easier than shifting deadlines to the left when they are discovered to be too late to be relevant.

Decision point	SPG	JPG	PDM
Chairman's Input	JPD or Other	CPR	CPA
Assumed release date	December	June	November
Lead-time needed for Chairman's input to influence decision	2 months	1 month	1 month
Implied timing for Chairman's input	October	May	October
Lead-time needed to integrate input	2 months	1 month	1 month
Implied deadline for input to Chairman	August	April	September

Figure 3.2: Timing Implications of Aligning Chairman's Inputs

The rows below the assumed release dates show backward-planning assumptions for aligning the required inputs to each decision point. The first of these, “lead-time needed for Chairman’s input to influence decision,” reflects the fact that even “decision” documents such as the SPG are preceded by much staff work, deliberation, and coordination. Timely input to each decision point must inform those deliberations. In the case of the SPG, the lead-time required to do this effectively is estimated to be two months, implying a need for the Chairman’s input to be submitted around October. The Chairman, in turn, requires lead-time to integrate the input submitted to him by various components and to organize that input into a single, coherent, joint perspective. In the case of the SPG, this lead-time is also estimated to be two months, implying a deadline of August for components to get their input to the Chairman. Similar timing implications apply to generating input to the JPG and the PDMs, as shown.

Given these timing implications, the next critical question is, what kinds of inputs are required at which point? Figure 3.3 summarizes the general scope of the required input, based on the scope of the decision points themselves, and also links these process steps back into the 8-question framework laid out in Chapter 2.

The first three questions address the substance of strategic guidance and broad assessments of existing capabilities and priorities for making changes. The next four lead to the more detailed analysis required to support programmatic guidance. Finally, the last question addresses the need to ensure compliance with guidance prior to the completion of the budget. The Aldridge Study’s vision for a more rigorous review of execution was considerably broader than what this alignment with the program review and PDM would

suggest. However, as noted in Chapters 1 and 2, implementation of such mechanisms has not yet materialized, and this paper does not address this subject directly.

Decision point	SPG	JPG	PDM
Implied deadline for input to Chairman	August	April	September
Nature of input	Strategic priorities Capability priorities Risk assessment Future concepts	Program priorities Trade-off assessment	Assessment of Component POMs Assessment of Processes
Questions that must be answered	<ol style="list-style-type: none"> 1. What do military forces need to be prepared to do? When? 2. Are the capabilities that are or will be available adequate and balanced? 3. What are the priority issues requiring greater effort? 	<ol style="list-style-type: none"> 4. What are the priority capability gaps within these issues? 5. How should the priority gap be addressed? 6. What programs can be decremented to fund higher-priority capability gaps? 7. What affordable mix of programs will provide sufficient capability at acceptable risk? 	<ol style="list-style-type: none"> 8. Is the system executing the decisions that were made?

Figure 3.3: Decisions, Timing, and Key Questions for Planning Processes

The connection between these questions, the processes required to answer them, and the key decision points provides an overarching frame of reference for the next step of the discussion. This next step, which is probably the most important and the most difficult aspect of refining capabilities development planning, is to construct effective Departmental decision support mechanisms. This is the subject of Chapter 4.

End Notes

¹ Honorable E.C. Aldridge, et al., Joint Defense Capabilities Study: Improving DoD Strategic Planning, Resourcing and Execution to Satisfy Joint Capabilities, Final Report, January 2004, pp. 2-9, 2-10.

² Ibid., pp. 2-16, 2-17.

³ USD(Comptroller) Overview of PPBE, available at <http://www.dod.mil/comptroller/icerter/budget/progphase.htm>

⁴ Testimony of Kenneth J. Krieg Under Secretary of Defense (Acquisition, Technology, & Logistics) before the United States House Committee on Armed Services, April 5, 2006.

⁵ Memorandum from Secretary of Defense Donald H. Rumsfeld, "Initiation of a Joint Capabilities Development Process," October 31, 2003.

Chapter 4: Improving Processes to Support Decision-Making

Alignment of capabilities development planning processes with the Department's key decision points is only the first step in improving the quality of decision support for capabilities development. In order to examine further the Department's processes for decision support, we return to the set of key questions introduced in Chapter 2:

1. What do military forces need to be prepared to do? When?
2. Are the capabilities that are or will be available adequate and balanced?
3. What are the priority issues requiring greater effort?
4. What are the priority capability gaps within these issues?
5. How should the priority gaps be addressed?
6. What programs can be decremented to fund higher-priority capability gaps?
7. What affordable mix of programs will provide sufficient capability at acceptable risk?
8. Is the system executing the decisions that were made?

An important theme links all but the last of these questions: the answer to each depends upon the results of some kind of mission analysis. The term "mission analysis" here refers to many different types of analysis that may vary widely in scope and levels of fidelity, but share the following characteristics: definition of mission objectives and assessment of the adequacy of existing or alternative capabilities to achieve those objectives.

In particular, the premise of the arguments outlined below is that efficient, rational decision support for capabilities development at the DoD headquarters level depends on high-quality joint mission analysis that is managed by joint organizations and adopts the perspective of the joint force. Accordingly, this chapter is largely focused on improving the conduct and management of joint mission analysis. It addresses this subject in four parts:

- Design and alignment of analytic processes
- Scenario development
- Concept development and experimentation
- Analytic methodologies

In addition, question 8 above, though not directly answerable through mission analysis, remains an important element of decision support. The last sections of this chapter address the execution of capabilities development decisions, through the management of acquisition programs in capability portfolios.

Before embarking on any assessment or reform of DoD processes, it is important to place on the record one overarching caveat. A healthy dose of modesty should leaven any concepts for coordinating the myriad activities involved in defense planning. Interactions

among political priorities, threat assessments, lessons learned from exercises and real-world operations, concept development, technology, fiscal environment, mission analysis, systems engineering, and other products and processes are far too complex to direct in any linear, centralized way. Even if centralized direction of a linear process were possible, it would not be desirable. Linear, sequential processes contribute to long acquisition times and are unresponsive to the needs of dynamic security challenges and technical opportunities. Agility and adaptation come from rapid learning and response through many scales of feedback. At the same time, major resource allocation decisions must be made by decision bodies at the most senior levels of the Department on timelines that are completely linear within a given budget cycle. Therefore, the goal of a “capabilities-based” system should not be to engineer planning processes to a fine level of detail, but rather to design an effective decision-support mechanism for regular, rigorous integration of planning process outputs.

Design and Alignment of Analytic Processes

The most fundamental of the eight key questions is the first one: what do military forces need to be prepared to do? While mission analysis is relevant to any answer, the question itself is primarily the province of strategic guidance, and therefore is largely addressed by factors and deliberations beyond DoD capabilities development planning processes. Indeed, the determination and prioritization of strategic missions is not strictly, or even primarily, an analytical task. Rather, the development of strategy at this level represents an expression of broad national values and interests and a vision for the integration of all elements of national power in the service of those interests.

How mission analysis can contribute to the first question is addressed below in the context of scenario development. But the first focus of this discussion of joint mission analysis is on the second question of the study framework: are the capabilities that are or will be available adequate and balanced? At the strategic level, answering this question demands holistic consideration of the full range of military operations and the capabilities resident in the entire joint force or otherwise available to it (from other US Government agencies or from allies).

In principle, DoD currently operates four parallel, overlapping processes that are designed to conduct and manage joint mission analysis for capabilities development planning at this level.

- COCOM Mission Analyses. COCOM commanders conduct mission analysis both as part of joint operation planning and as part of the Joint Training System.
 - Mission analysis is the first step in the concept development phase of deliberate planning. The assigned task is analyzed, a mission statement is deduced, subordinate tasks are derived, alternative courses of action are developed and war-gamed, analyzed, and compared to produce the combatant commander’s strategic concept. When approved by the Chairman, the concept of operations (or CONOPS) at the core of this strategic concept is expanded into a complete plan.¹
 - COCOM commanders also analyze their assigned missions and plans to develop a list of specified and implied tasks to provide the basis for training

plans and programs. Tasks derived from mission analysis are translated into a common reference language using the Universal Joint Task List (UJTL) and further analyzed to produce the Joint Mission-Essential Task List (JMETL) that provides the foundation for training requirements.²

- Capability gaps or resource shortfalls that could hinder the performance of assigned missions are reported in the COCOM commander's IPL. The IPL is a list of the commander's highest priority requirements, prioritized across Service and functional lines, which define gaps in key capabilities.³ Now, COCOMs are required to identify areas where they can accept greater risk and suggest offsets to compensate for investments to remedy priority capability gaps.
- Enhanced Planning Process. The Aldridge report described the EPP as having been “designed to link strategy to program development by assessing current capabilities, analyzing gaps and excesses, and recommending alternatives for the Secretary's decisions.”⁴
- Joint Capabilities Integration and Development System. The analytic heart of JCIDS is the Capabilities-Based Assessment. The current JCIDS instruction directs that, through CBAs, “JCIDS . . . utilizes joint concepts . . . to identify prioritized capability gaps and integrated DOTMLPF and policy approaches . . . to resolve those gaps.”⁵
- Analytic Agenda. Much of the activity conducted under the auspices of the Analytic Agenda involves scenario and data development. However, a limited number of major joint studies, including in particular the OA-series studies, are also conducted as part of the Analytic Agenda. The Analytic Agenda, itself, was established to serve exactly these kinds of “strategic analyses.” A key implementing DoD Directive for the Analytic Agenda defines the purpose of strategic analysis of future forces as “analysis of the sufficiency and effectiveness of future forces. . . . Such analyses examine force structure and program alternatives and evaluate risk.”⁶

Figure 4.1 summarizes some key characteristics of each of these processes.

All four of these processes have similar inputs, outputs, and participants. But two important problems inhibit their utility in capabilities development decision making. First, the timing of these process outputs is not well coordinated with the key planning decision points described in Chapter 3. Second, these processes are not well coordinated with one another. While each process may legitimately claim a definitive perspective on some capability needs issues at any given time, none can claim an integrated perspective on all issues on a predictable, dependable schedule. This means that senior decision makers, themselves, serve as the first and last points of integration in the Department for answering the question “are the capabilities that are or will be available adequate and available?”

Given this situation, there is a clear need to improve the synchronization of the multiple joint mission analysis activities currently supporting capabilities development planning.

Such synchronization, of course, is not straightforward. Any improvements must address at least four dilemmas inherent in the management of these processes.

	COCOM Mission Analyses	Enhanced Planning Process	Analytic Agenda Studies	CBAs (FAA, FNA only)
Current status	<ul style="list-style-type: none"> Ongoing 	<ul style="list-style-type: none"> Unaddressed by 2006 SPG Tied to QDR execution roadmaps 	<ul style="list-style-type: none"> Ongoing Primary study vehicle is the Operational Availability (OA) series 	<ul style="list-style-type: none"> Ongoing
Examples of completed analyses	<ul style="list-style-type: none"> OPLAN analyses 	<ul style="list-style-type: none"> JFEO JUSS 	<ul style="list-style-type: none"> OA study series Mobility Capabilities Study (MCS) Joint Air Dominance (JAD) 	<ul style="list-style-type: none"> JFEO JUSS IAMD
Lead analytic agent(s)	<ul style="list-style-type: none"> COCOMs 	<ul style="list-style-type: none"> OSD/PA&E 	<ul style="list-style-type: none"> Joint Staff J-8 OSD/PA&E 	<ul style="list-style-type: none"> FCBs
Main inputs	<ul style="list-style-type: none"> Strategic guidance Joint Doctrine & Concepts 	<ul style="list-style-type: none"> Strategic guidance Joint concepts Scenarios 	<ul style="list-style-type: none"> Strategic guidance Joint concepts Scenarios 	<ul style="list-style-type: none"> Strategic guidance Joint concepts Scenarios
Main outputs	<ul style="list-style-type: none"> Prioritized joint capability needs Gaps and excesses Occasional JCDs 	<ul style="list-style-type: none"> Prioritized joint capability needs Gaps and excesses 	<ul style="list-style-type: none"> Prioritized joint capability needs Gaps and excesses 	<ul style="list-style-type: none"> Prioritized joint capability needs Gaps and excesses JCDs
Main participants	<ul style="list-style-type: none"> Cross-functional teams of experts from all components 	<ul style="list-style-type: none"> Cross-functional teams of experts from all components 	<ul style="list-style-type: none"> Cross-functional teams of experts from all components 	<ul style="list-style-type: none"> Cross-functional teams of experts from all components
Timing of outputs	<ul style="list-style-type: none"> Varies 	<ul style="list-style-type: none"> Supposed to be ongoing year-round Report out to inform JPG 	<ul style="list-style-type: none"> Varies 	<ul style="list-style-type: none"> Varies

Figure 4.1: Summary of Parallel Joint Mission Analysis Processes

Dilemma #1: Senior leaders’ time is limited and therefore must be focused on the highest-priority capability issues. BUT, capability needs identification and trade-off assessments require a holistic view of all capability issues.

Dilemma #2: Programmatic recommendations and decisions must be responsive to the latest strategic guidance. BUT, time between issuance of the SPG and the CPR and JPG is not sufficient to conduct a full cycle of needs prioritization, solutions analysis, and trade-off assessment.

Dilemma #3: Joint analytic capacity is scarce and good mission analysis requires collaboration across entities, so there is great synergy in collaborative OSD and Joint Staff analytic activities. BUT, the congressional mandate that the Joint Staff be independently organized and operated could limit the scope of collaboration with OSD.*

Dilemma #4: Uncertainty in the strategic and tactical environments demands comparative analysis across a wide range of variability in threats and environmental parameters. BUT, senior leaders must have some common framework within which to adjudicate competing claims based on multiple analyses emphasizing different variables.

* The Goldwater-Nichols Act specified that the Chairman manages the Joint Staff and that it is to perform such duties as the he prescribes, under such procedures as he prescribes. The Act directed the Secretary to “ensure that the Joint Staff is independently organized and operated so that the Joint Staff supports the Chairman.” The Chairman’s requirement to assess programs and budgets formulated by other DoD components and submit alternatives implies that his advice in this regard is to be independent of that from other DoD components. To develop such advice he needs the full and unfettered analytic capacity of the Joint Staff. See Title 10 United States Code Sections 155(c) and (d), and Section 153(a)(4).

The first dilemma is perhaps the most important and dictates to a significant extent the requirements for design and alignment of joint analytic processes. How can both the breadth and the depth required for decision support be accommodated? In simple terms, this dilemma can be resolved by conducting broad, shallow mission analysis across all missions and all forces to identify problems that need to be solved, and then deep, narrow analysis on solving a small number of those problems, in keeping with priorities established by senior leadership.

Several frameworks for implementing this general principle are undoubtedly feasible, but it is critical that whatever framework is adopted be compatible with – and explicitly linked to – existing processes. In the next few pages, such a framework is proposed as a central pillar of an improved capabilities development planning system. It should be emphasized that this prescription is offered not for the entire defense analytic community, but rather as a guide for joint analysis by joint organizations who maintain responsibility for supporting integrated decision making for capabilities development, such as OSD (PA&E) and the Joint Staff (J-8).

The framework proposed here is based on the conduct of joint mission analysis at three different levels in four major process steps.

- Level 1 – Issue Identification and Prioritization: Low resolution, holistic, force-wide analysis of the current force or the “programmed force” (end of the FYDP) and its assigned missions to generate first-order assessment and prioritization of capability gaps, excesses, and risk. This step identifies the most important problems to be studied in greater depth, and at the same time identifies capabilities that may be lower in priority or overabundant and thus potential “bill-payers” for higher priority needs.
- Level 2 – Capability Assessments: Medium and high-resolution analysis of prioritized capability issues. Whereas the first step identified the most important problems to be studied, this step carries out those studies to identify the specific problems that need to be solved through the development of new capabilities.
- Level 3 – Solution Development: High resolution analysis of alternative DOTMLPF and policy approaches and solutions to the prioritized “problems to be solved.” This step aims to identify the best options for solving the most important capability problems.
- Level 1 – Trade-off Analysis: Programmatic trade-off analysis based on the solutions generated at level 3 and the lower-priority capabilities identified in any earlier step. This step returns to the broad lens of level-1 analysis.

Conceptualizing analysis and decision making in three such levels is consistent not only with the way some senior leaders have characterized capabilities-based planning in the past,⁷ but also with ongoing efforts to advance DoD “Institutional Reform and Governance.”⁸

Figure 4.2 summarizes how these steps and levels might operate and interact, including how current DoD analytic activities and joint concepts map to the framework.

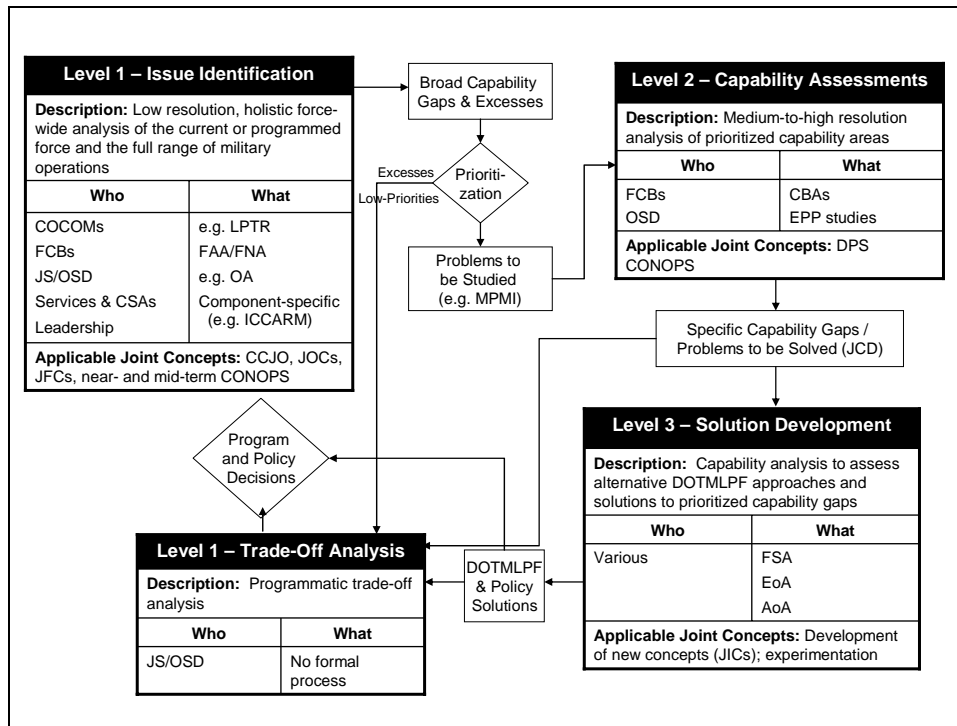

Figure 4.2: Levels of Joint Mission Analysis

Level 1

The goal of level-1 issue identification analysis is to generate a high-level understanding of capability gaps and excesses, based on comparison of existing or programmed capabilities and existing or projected missions. This type of information is produced throughout the Department using various processes and methods. Some of these are listed in Figure 4.1. COCOM commander IPLs generally fall into this category (though some IPL input is more specific and programmatic). Linking Plans to Resources (LPTR) is one methodology for conducting this type of analysis that has been developed at US Pacific Command (USPACOM) and is being employed at other commands.⁹

In principle, the Functional Area Analysis and Functional Needs Analysis elements of a JCIDS CBA would involve this type of mission analysis. However, for these assessments to meet the needs of level-1 analysis, they would have to cover all functional areas for a specified set of missions and scenarios (such as those identified as QDR priorities). Though JCIDS instructions establish just such an intent for FAAs and FNAs,¹⁰ in practice, FAAs and FNAs have typically been scoped too narrowly to provide a holistic appraisal of gaps and excesses. Options for modifying JCIDS implementation to address this issue are discussed below and in Chapter 5.

Some elements of the Joint Staff-led OA-series studies also meet the description of level-1 joint mission analysis. In particular, the studies that focused on rotation base requirements in OA '05 and force structure in OA '06 produced analytic output on broad gaps and excesses from the perspective of the entire force and a full range of military operations.

Another important output of level-1 analysis is an assessment of risk in the context of the entire defense strategy. Formal risk assessment is not only a useful analytic tool for aggregating disparate performance metrics into judgments on strategy, but also a statutory requirement for DoD (See Appendix G). Notwithstanding a great deal of discussion of risk in strategic planning and guidance documents, formal risk assessment remains relatively immature in the Department, especially at the strategic level. As noted in Chapter 3, while the CRA employs a formal method for such analysis, it focuses more narrowly on military operational risk and is not designed to produce insights for capabilities development planning. A formal strategic risk assessment conducted at the senior levels of the Department would be another valuable type of level-1 joint mission analysis. Such an assessment was piloted by IDA on behalf of OSD and the Joint Staff in 2005 under the auspices of the Integrated Cross-Capability Assessment and Risk Management (ICARM) study.¹¹

Output from level-1 analyses should provide decision makers with an inventory of the joint force's strengths and weaknesses as it is programmed and projected to change over time that is comprehensive both in terms of substance and organizational perspectives. However, the various issues raised by level-1 analyses are not likely to be of equal importance to the joint force. Even if they were, the limited management and analytic capacity of senior leadership and joint organizations cannot effectively address every issue at the same time. Issues must be prioritized in order to focus joint management and analytic attention on the most important problems to be studied and solved.

The importance of issue prioritization in joint decision making has been a common theme of recent studies on DoD management reform.¹² More recently, the JROC has initiated a process for conducting this kind of issue prioritization. Under this new process, the Joint Staff will produce a list of "Most Pressing Military Issues" (MPMI) based on inputs from throughout the Department.¹³

In the scheme outlined here, a small number of broad issues – such as "tagging, tracking, and locating" (TTL) or psychological operations (PSYOP) capabilities – would be identified for more detailed (level-2) joint analysis. Further analysis and option development for issues falling outside that list of MPMI would be left to component organizations. It is important to note that in addition to MPMIs, large programs (ACAT 1) and those below-threshold programs designated as of special Defense Acquisition Board (DAB) interest by the USD(AT&L) that the VCJCS must address, and other JROC interest items would also be given significant joint analytic attention as required.

Level 2

Level-2 joint mission analyses would then be dedicated to studying the prioritized issues, with the goal of identifying more specific capability needs at a level of detail sufficient to enable development of solution options. Whereas level-1 analyses would identify the most important "problems to be studied," level-2 analysis would identify the most important "problems to be solved." For example, if TTL and PSYOP were identified as problems to be studied, problems to be solved might include radiological signature detection for TTL, and Arabic language skills for PSYOP.

The nature and scope of level-2 analysis aligns well with the FAA and FNA elements of JCIDS capabilities-based assessments as they have been implemented to date.

Similarly, the intended output of level-2 analysis matches that directed by JCIDS for Joint Capabilities Documents (JCDs). Other existing joint analytic processes that operate at this level are reflected in past EPP studies, such as the Joint Undersea Superiority Study, and some Analytic Agenda studies, such as the Mobility Capabilities Study (MCS).

Level 3

Level-3 mission analyses, then, aim to develop and evaluate alternative solutions to the “problems to be solved” identified through level-2 analyses. Solutions may come from any of the DOTMLPF elements as well as from changes in policy.

Level-3 analyses correspond directly with existing analytic processes such as the Functional Solutions Analysis (FSA) portion of JCIDS capabilities-based assessments and with Analysis of Alternatives (AoA) studies. Significant changes currently underway to these existing processes are designed to improve the operation of the “hand-off” from JCIDS to the Defense Acquisition System. These changes will be described in more detail below, but the centerpiece of these changes, the Concept Decision process outlined in Chapter 1, is consistent with the framework proposed here.

It is important to note that level-1 and -2 analyses deal with capabilities, referencing programs only to understand the capabilities that those programs (as manifested in platforms, systems, and military units) provide. Sponsor program proposals and other proposed solutions enter the process at level 3, after analysis of problems to be studied and problems to be solved.

Level 1 Trade-off analyses

Finally, while effective execution of the first three steps should generate high quality solutions for the most important capabilities to the joint force, senior decision makers ultimately must make major programmatic and policy choices in the broadest possible context. Capability alternatives must be evaluated not only within capability areas, but across all capability areas and in relation to the resources that are available to pay for them. This requires a return to level-1 joint mission analysis, in this case aimed at informing budgeting and programmatic choices rather than identifying issues. As in the first level-1 step, strategic risk assessment should play a central role in this step.

Unlike for the three steps described above, no formal process currently exists in the Department for conducting level-1 trade-off analysis. Instead, the Deputy Secretary and Secretary personally end up serving as the first points of integration for evaluating the myriad options generated by the various components participating in the capabilities development process. This is one of the most important weaknesses of current analytic processes for decision support in DoD. The level-1 trade-off analyses that identify capability areas in which to accept risk will need to be augmented by more detailed level-2 analyses to evaluate the effects of decrementing particular programs, and level-3 analyses of particular programs to produce resource-neutral trade-offs. The current processes that exist to produce the CPR, CPA, JPG, and PDMs and PBDs are driven almost exclusively by assessment of individual programs, with little assessment of the impact of program changes on proficiency and sufficiency of forces to conduct assigned missions. The inability to identify offsets is the principal reason that the JPG to date has not come close to achieving the role envisioned in the Aldridge report.¹⁴

As the preceding discussion demonstrates, existing analytic processes possess many of the characteristics of the framework described here. However, as also noted above, existing processes are not well coordinated with one another or with key decision points, substantively or in terms of schedule. Additionally, a few key steps, such as issue prioritization and formal level-1 trade-off analysis, are not addressed by any well-established, holistic joint process. Considerations for matching the above framework to existing processes, decision points, and timelines are summarized in Figure 4.3.

If this were accepted as the general design and flow for joint mission analysis processes, how could it be brought into alignment with the key DoD capabilities development planning decision points? Figure 4.3 shows the decision points each analytic step is tailored to inform, and the implied timing for integrated output from those steps that was presented in Chapter 3. Here, we return to the earlier discussion of the dilemmas involved in the management of joint analytic processes. Dilemma #2 is that programmatic recommendations and decisions must be responsive to the latest strategic guidance, but the time between issuance of the SPG and the CPR and JPG is not sufficient to conduct a full cycle of issue identification and prioritization, needs assessment, solutions development, and trade-off assessment.

	To inform which decision point(s)?	Implied suspense for integrated output	Examples of current processes for performing this function	Issues
<p>Level 1 (Issue Identification & Prioritization): Low-resolution, holistic, force-wide analysis of current or programmed force to generate first-order assessment of gaps, excesses and risk balance</p>	SPG (and CJCS input to SPG (e.g. JPD))	August	<ul style="list-style-type: none"> IPLs FAA and FNA portions of CBAs Some Analytic Agenda studies (e.g. OA) 	<ul style="list-style-type: none"> Studies not aligned with decision points FAA/FNA usually scoped too narrowly to provide holistic appraisal of gaps/excesses Incommensurable data from different processes System for prioritizing issues for senior leader focus (MPMI) is just emerging, not yet institutionalized
<p>Level 2 (Capability Assessments): Medium-to-high resolution analysis of prioritized capability areas</p>	JCD	Ongoing	<ul style="list-style-type: none"> CBAs EPP studies Some Analytic Agenda studies (e.g. MCS) Some JCD&E 	<ul style="list-style-type: none"> Status of EPP is unclear CBAs not focused on highest priority military issues Analysis strongly influenced by solution proponents
<p>Level 3 (Solution Development): Capability analysis to assess alternative DOTMLPF approaches and solutions to prioritized capability gaps</p>	Concept Decisions / Trade-off Assessment	Ongoing with annual report out in March	<ul style="list-style-type: none"> FSA portions of CBAs AoAs EoAs in new proposed process Some JCD&E 	<ul style="list-style-type: none"> Lack of issue prioritization results in slow process and output that does not always address most important joint capability needs
<p>Level 1 (Trade-Off Analysis): Programmatic trade-off analysis of solutions/ options generated by Steps 1-3.</p>	JPG (and CPR)	April	<ul style="list-style-type: none"> No formal process 	<ul style="list-style-type: none"> No formal process

Figure 4.3: Current Issues with Joint Mission Analysis

The first step toward resolving this dilemma is simply to recognize that alignment of programs and strategy is a continuous, iterative activity, not a singular event. Having said this, the process outlined above can readily be shaped to provide regular and timely decision support. Three points about the proposed process stand out:

- Conducting broad level-1 mission analyses as an *input* to SPG development, rather than in *response* to SPG guidance, allows for longer lead times in study design and

execution. Moreover, there will likely be strong correlation between the analytic input to the SPG guidance and the guidance itself, since the latter should be based in part on the former.

- Prioritizing capability issues for examination through joint analysis and senior leadership review should reduce and focus the workload for joint analysts and decision makers, and thereby increase the quantity and quality of programmatic guidance on the most important issues for any given JPG.
- One critical feature of an efficient analytic decision support system is a common framework and data structure for all major joint analyses. This feature would not only enable comparability of analytic results across multiple study efforts, it would also enable relatively easy incorporation of previous work conducted on related topics. Common Department-wide taxonomies for missions, capabilities, and forces, including rules for mapping taxonomies to each other, are central to building a common framework and data structure. Joint Capability Areas (JCAs) represent an important step toward this objective.

So, given the decision points and timelines identified in Figure 4.3, and the considerations above for resolving Dilemma #2, how do the proposed processes for joint mission analysis fit together? Figure 4.4 applies these processes to the timeline presented in Chapter 3.

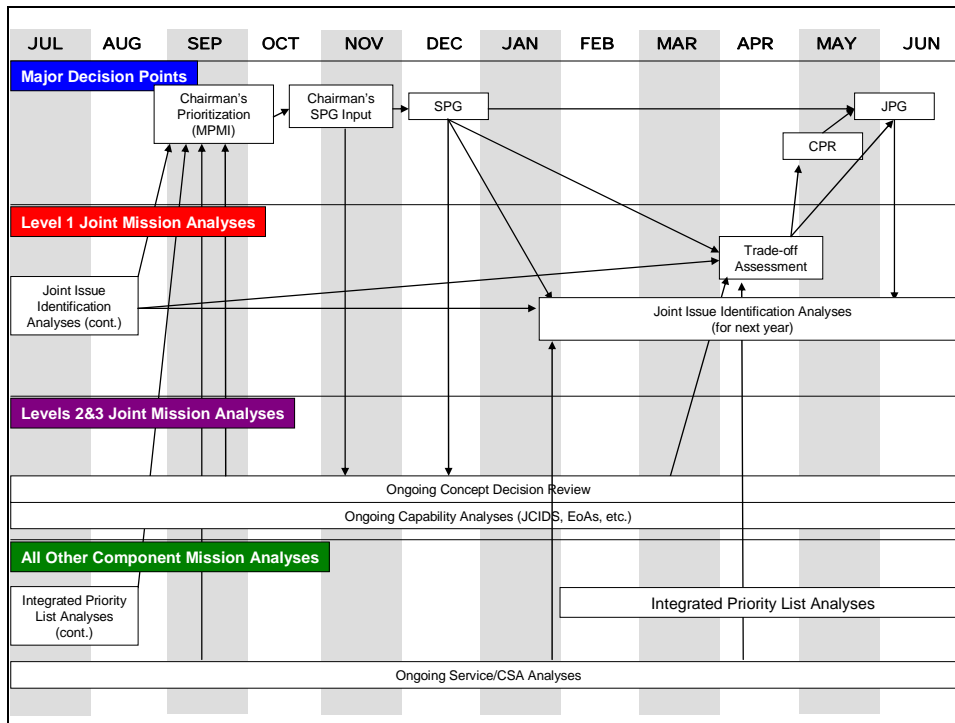

Figure 4.4: Timeline for Aligning Mission Analyses and Decision Points

The first point to be made on the alignment of joint mission analysis and major decisions is to reiterate the distinction made earlier between regular, periodic processes and ongoing processes. In this framework, level-1 joint mission analyses would typically be

regular periodic processes, timed to serve major decision points like the SPG and the JPG. Joint mission analyses at levels 2 and 3 are ongoing processes. They receive regular periodic guidance, and need to provide formalized output on a regular periodic basis (as shown by the arrows in Figure 4.4), but these types of analyses constitute some of the day-to-day activity of the Department. In this sense, the level-1 processes serve as filters that collect and integrate the information that is constantly being created and changed by processes at levels 2 and 3.

Additionally, many of the timelines discussed in the proceeding few pages could be implemented as either annual or biennial processes. As noted in Chapter 3, the baseline calendar for this analysis is a non-QDR budget “on-year” in the biennial PPBE cycle. The discussion here will make reference to “on-years” and “off-years” in this context. (Note that “on-years” and “off-years” refer to calendar years, not fiscal years.) However, it is also assumed that significant analytic activities will continue in support of off-year budget preparation, and that much of the decision support system should therefore be composed of annually repeatable processes.

Given these considerations, discussion of process alignment must begin with level-1 analyses. As indicated in Figure 4.3, the first step of level-1 analysis should inform the guidance provided in the SPG. Further, as outlined in Chapter 3, this implies a deadline for the output of level-1 analyses around August, prior to the December issuance of the SPG. The beginning of level-1 analyses could be flexible, but two factors suggest an annual start date of January. First, all analytic work on the prior on-year budget submission is complete by January. Second, any off-year planning guidance (in the form of an optional SPG, or otherwise) should be issued around the beginning of the off-year. In this scheme, then, each cycle of level-1 joint mission analyses would last approximately eight months, from January to August.

What implications would this have for current processes? One important change this implies is in the deadline for submission of combatant commander IPLs. IPLs are normally submitted in November, so the August deadline suggested here would entail moving the IPL generation process at the combatant commands back by three months.

As noted above and summarized in Figure 4.3, the other two main vehicles for conducting level-1 joint mission analyses are the FAA and FNA portions of CBAs and the OA-series studies. While much valuable analysis is conducted as part of these processes, from a Departmental perspective, a lack of coordination among the processes and key decision points does not make optimal use of scarce joint analytic resources and inhibits coherent linkages between analytic results, planning guidance, and programmatic decision-making. The following three options could significantly improve the output and coordination of level-1 joint mission analyses.

Option 4-A: Conduct regular FAA and FNA across each Joint Functional Concept (JFC)

Description: Each FCB is currently responsible for developing and maintaining a Joint Functional Concept (JFC) that covers its assigned functional area. Under this option, each FCB would conduct a regular (e.g., annual) FAA and FNA on its assigned JFC to identify (1) all the tasks that need to be performed within the

assigned capability areas, across the range of military operations; and (2) all the capabilities that exist or are programmed to exist, year-by-year through the end of the FYDP. The resulting inventory of tasks versus capabilities would reveal the capability gaps and excesses in the programmed force.

Pros: In combination, all FAA/FNAs would provide a holistic view of the entire force; JFC-wide FAA/FNA is consistent with direction in CJCSI 3170.¹⁵

Cons: Current capacity of the FCBs to manage this process is unclear; potential overlap in analytic objectives with OA-series studies.

Option 4-B: Realign OA to directly support SPG development.

Description: OA study Terms of Reference would be based on previous planning guidance and would require reports in time to influence new planning guidance.

Pros: Analysis of force structure and broad capability areas is better suited to planning guidance than to programming guidance; shift in timing provides formal analytical basis for development of strategic guidance that is currently missing.

Cons: None identified.

In addition to changes in content and alignment of level-1 analyses, the framework proposed here suggests opportunities to address Dilemma #3, which helps frame the management challenges currently facing joint mission analysis. (Joint analytic capacity is scarce and good mission analysis requires collaboration across all entities, so there is great synergy in collaborative OSD and Joint Staff analytic activities, but the congressional mandate that the Joint Staff be independently organized may limit the scope of collaboration with OSD.)

The Aldridge Study confronted this dilemma directly, and offered a few organizational alternatives to address it.¹⁶ Drawing on those alternatives, among others, it seems clear that at least two complementary options could be helpful in this regard. First, the joint analytic community could use the following rule of thumb for division of labor: design and conduct joint mission analyses in collaborative OSD-Joint Staff processes; and conduct integration of analyses and prioritization of issues independently. Second, the Department could expand its joint analytic capacity. This would include increases in both OSD and Joint Staff analytic resources and could include a combination of increased staffing and contract support. More specific options for improving management of level-1 joint mission analysis include the following.

Option 4-C: Implement the EPP as envisioned in the Aldridge Study.

Description: OSD (PA&E) would oversee and integrate level-1 joint mission analyses.

Pros: This is consistent with PA&E's traditional and statutory role and can be implemented with existing organizations and authorities.

Cons: Having one organization conduct its own analyses and be responsible for integrating analyses done by others may inhibit the "honest broker" role; leaves unaddressed the need for a separate integrated product for CJCS.

Option 4-D: Create new OSD/Joint Staff analytic management function.

Description: OSD and the Joint Staff would share responsibility for oversight and integration of level-1 joint mission analyses. This could (but need not) include the consolidation of JFC-wide FAA/FNAs and OA-series studies into a single process.

Pros: Enables collaborative approach to analytic priorities and management; economizes utilization of scarce joint analytic resources.

Cons: May inhibit ability of OSD and the Joint Staff to generate independent advice to the Secretary and Chairman, respectively; may exacerbate pressures toward lowest-common-denominator results.

Option 4-E: Create new OSD “decision support cell.”¹⁷

Description: New organization directly under the Secretary of Defense would oversee and integrate joint mission analyses.

Pros: Enables “honest broker” role in integration of analysis for the Secretary.

Cons: Potentially duplicative of PA&E responsibility; leaves unaddressed the need for a separate integrated product for CJCS.

Option 4-F: Expand joint analytic capacity.

Description: Increase allocation of resources to OSD, Joint Staff, and COCOM analytic staff and/or increase funding available for contracting outside studies.

Pros: Responds to increased need to account for variability and consider multiple capability alternatives; improves the quality of joint analysis.

Cons: Cost; shifting analytic resources from components to OSD, the Joint Staff and COCOMs would be politically difficult.

Returning to the language of the general study framework, level-1 analyses are designed to answer two of the eight main questions: Are the capabilities that are or will be available adequate? And what programs can be decremented to fund higher-priority capability needs? The third critical question is, what are the priority gaps requiring greater effort? As noted, the JROC has recently initiated a formal process (MPMI) for prioritizing capability needs collected from military components throughout the Department. This process is designed to answer the third question of the framework and in so doing, focus the effort of joint mission analysis.

This new process is identified in Figure 4.4 as the “Chairman’s Prioritization (MPMI)” and targeted for September or October, probably annually but at least in every off-year. This timing is driven principally by the need to inform a potential Chairman’s formal SPG input, which would be targeted for November completion (see Option 3-A). This process specifically serves the needs of the Chairman, but its findings are also appropriate and relevant inputs to any analogous prioritization effort conducted by the Secretary and his staff. Such a process within OSD should be (and already is, at least informally) conducted in the course of developing the SPG.

Next, as shown in Figure 4.4, the issue priorities recommended in the Chairman’s SPG input and promulgated in the SPG itself would serve as guidance to the design and

conduct of ongoing level-2 and level-3 joint mission analyses. The overarching goal of level-2 analysis is to answer the fourth question of the study framework: What are the priority capability gaps within [the prioritized] issues? In other words, level-2 analyses translate “problems to be studied” into “problems to be solved.” In JCIDS terms, a key product of level-2 analyses would be the JCD. While JCIDS is not the only existing joint analytic activity operating at level-2, it is the centerpiece of the Department’s requirements identification process, so the following discussion of level-2 and level-3 analysis is focused on JCIDS.

There are a few important discrepancies between the framework laid out here and the current operation of JCIDS. Perhaps the most important is that the process tends to be driven more by sponsors’ specific program proposals than by a holistic view of joint priority needs. Indeed, the role that JCIDS assigns to the “sponsor” encourages this approach. A sponsor is “the DoD component, principal staff assistant or domain owner responsible for all common documentation, periodic reporting and funding actions required to support the capabilities development and acquisition process for a specific capability proposal.”¹⁸ Added to this is the fact that “functional” area and needs analysis terminology confuses capability-based assessments that are usually oriented narrowly on specific missions (e.g. Joint Undersea Superiority, Joint Forcible Entry Operations) rather than on the full extent of FCB functional areas. Additionally, the ability of sponsors (principally Services) to choose which scenarios to use for their analyses dilutes the ability of senior decision makers to compare and contrast the results of those analyses. Finally, the selection of program sponsors to conduct solution analyses certainly colors the solutions that are considered in the process.

The following options could bring JCIDS analyses into closer alignment with the framework proposed here:

Option 4-G: Reserve “functional” terminology for FCB functional areas.

Description: Reserve the terms FAA and FNA for level-1 analyses conducted by FCBs across their entire assigned functional areas and focus CBAs on level-2 capability needs analyses for priority issues identified in CJCS and SecDef planning guidance.

Pros: Mitigates confusion over levels of analysis; focuses CBAs on most important military issues.

Cons: Turmoil accompanying implementation of new practices.

Option 4-H: Mandate use of OSD-approved / JROC-designated scenarios as baselines.

Description: CBAs conducted by the Services and Agencies, both as part of their internal processes and for JROC-directed CBAs, would be required to use specific, approved Blue Force CONOPS drawn from designated DPSs for analyses beyond the FYDP or, for analyses within the FYDP, the CONOPS in combatant command operation plans. CBAs would be free (indeed, encouraged) to explore alternatives to the common baseline.

Pros: Scenarios are essential to determining the conditions under which tasks must be accomplished and the standards that must be achieved; analyses would be based on joint perspectives and common assumptions.

Cons: Services may resist efforts to impose scenario standardization; COCOMs may resist efforts to expose the CONOPS on which their war plans are based.

Finally, level-3 analyses, such as FSAs and the newly-launched Evaluation of Alternatives (EoA),¹⁹ seek to answer question #5 of the study framework: how should the priority gaps be addressed? This question is composed of three distinct sub-questions:

- What concepts can remedy priority gaps?
- What new capabilities need to be developed?
- What new approaches, systems, platforms, or programs will provide the needed capability?

It is important to note that many, indeed most, proposed solutions to priority gaps will not be generated and evaluated in the time between the issuance of planning guidance for a given budget cycle and the follow-on development of programming guidance. In certain cases, this aggressive timeline may be feasible due to the immediate availability of viable solutions. In others, such an aggressive timeline may be necessary based on the needs of the joint force, and would have to be achieved through acceleration of the deliberative analytic processes described here. But for most issues, analyses for levels-2 and 3 will operate somewhat according to their own rhythms based on the nature of the problems involved.

As with level-2, there are some discrepancies between JCIDS as currently practiced and the level-3 analyses envisioned here. First, sponsors that have solutions to propose and also have acquisition responsibilities are generally self-selected or appointed to conduct solution analyses. Given the current limitations of joint analytic capacity, this is inevitable to some extent, but it may have the effect of compromising the objectivity, or at least the breadth in perspective, of solution analyses. Second, solutions analyses are almost exclusively “paper” analyses without the benefit of experimental articles or prototypes for early user interaction with the developer. This linear process, relying upon modeling and simulation and requirements documents with little interaction between users and developers, contributes to long lead times to remedy capability gaps.

The following options could bring JCIDS solutions analyses and JCD&E into closer alignment with the framework proposed here:

Option 4-I: Encourage multiple sponsors to compete for solution analyses.

Description: Services and CSAs would conduct their own solution analyses and provide alternatives to a formal EoA.

Pros: Provides a greater range of solution concepts employing existing Service analysis organizations; provides greater joint perspective to the EoA process.

Cons: Requires oversight to evaluate multiple solution approaches; Services may object to changes in the system.

Option 4-J: Employ JCD&E as integral part of solution analysis.

Description: Use human-in-the-loop simulation, field trials with surrogates, experimental articles, and prototypes to “test drive” technologies; co-evolve DOT_LPF with M; “tinker to see what works” as part of the Concept Refinement process, with feedback to the Concept Decision.

Pros: Concentrates efforts on filling capability gaps; as confidence in a solution is gained, facilitates transition to “normal” acquisition process; enables pressing problems to be checked off the MPMI list; promotes co-evolution of DOTMLPF by developers and users to accelerate fielding; provides evidence for selection among alternative solutions that analysis without experimentation cannot provide.

Cons: Requires balance among JCD&E efforts to support level-1, 2, and 3 analyses to prevent time horizon for JCD&E becoming too near-term. Services may view as a threat to their freedom of action.

Option 4-K: Employ proposed EoA process for MPMI.

Description: Chairman would focus Joint Staff and FCB efforts on MPMI and use these to influence the new Concept Decision process.

Pros: Provides Chairman with leverage over which issues are selected for Concept Decision process.

Cons: Would need some additional effort to address ACAT 1 proposals, those below-threshold programs designated as of special DAB interest by the USD(AT&L)), and other JROC interest issues.

The final step of the process outlined in Figure 4.2 is the assessment of program trade-offs that match available resources with the solution alternatives generated by level-3 analyses and the lower priorities and redundancies generated by the first step of level-1 analyses, or by any other analyses. This process would help to answer question #7 of the study framework: what affordable mix of programs will provide sufficient capability at acceptable risk? As shown in Figure 4.4, this step should occur around April or May because the fiscally constrained options for programmatic trades (for addressing top priority capability issues) that it is meant to produce are intended to inform the JPG (and therefore the CPR). Due to the holistic, strategic perspective required for recommending broad, force-wide trade offs, this analysis is characterized here as a return to the level-1-type of analysis.

Today, no such process exists. The following summarizes an option to create this process.

Option 4-L: Establish formal level-1 trade-off assessment analysis.

Description: Recurring (annual or biennial) process for producing candidate programmatic trades and assessing risk of alternative programmatic options would be conducted in April-May to inform JPG and CPR development. Responsibility could be shared between OSD(PA&E) and Joint Staff (J-8).

Pros: Fills a critical gap in joint analytic processes; enables fiscally-constrained programmatic guidance decisions to be made in time to influence the JPG (and therefore POM development).

Cons: Would require the development of agreed methodology and business rules, and the addition or reallocation of joint analytic resources; shared OSD/Joint Staff responsibility could encroach on the independent operation of the Joint Staff.

In summary, joint mission analysis should be the foundation of capabilities development planning. While JCIDS, Analytic Agenda studies, and many other existing processes in the Department have taken great strides in recent years toward improving the design and alignment of joint analytic processes, opportunity remains to further improve these processes and the support they provide to strategic decision making.

So, if we accept the premise that joint mission analysis should be the basis for capabilities-based decision making, then the next question should be: what is the basis for joint mission analysis?

Two critical common threads can be found among three existing joint mission analysis processes identified above in their descriptions of how analysis should be conducted (boldface added):

- EPP: “At the heart of the process is a comparison of current capabilities with those needed to perform tasks and missions. **Scenarios and concepts** give context to the tasks and missions.”²⁰
- JCIDS: “Strategic policy guidance, the **Family of Joint Future Concepts, CONOPS, and the Defense Planning Scenarios** provide a common construct for analysis to determine joint warfighting capability needs and to identify capability gaps or redundancies.”²¹
- Analytic Agenda Studies: “[An] analytic baseline [is] a package comprising a **scenario, concept of operations**, and integrated data . . .”²²

The common threads that form the foundation of joint mission analysis are **scenarios** and joint **concepts**. Note that scenarios and concepts also play a role in the mission analysis conducted by COCOM commanders as part of force employment planning and execution. Their “scenario” comprises the planning task assigned in the CPG and other sources of force employment planning guidance; the forces apportioned in the GFMG; the adversary forces as assessed by the intelligence community; and the specific objectives, timelines and constraints established in SGSs. Their “concept” is the CONOPS embedded in the strategic concept that the COCOM commander and his staff develop during deliberate planning. These mission analyses focus on current capabilities and their outputs include gaps and redundancies in the current force, reported in IPLs, readiness reports, etc. As noted in Chapter 1, these outputs from the force employment planning side of capabilities-based planning serve as important inputs to the capabilities development planning side.

As is true of this entire report, the following discussion of scenarios and concepts is focused on the capabilities development planning side; the discussion that follows is about scenarios and concepts in the future, beyond the FYDP.

Scenario Development

Fundamentally, scenarios are what allow the Department to answer the first question of the study framework (What do military forces need to be prepared to do?) for timeframes beyond the near-term. This section provides a brief overview of the status of planning scenarios in supporting joint mission analyses, and some options for improving their usefulness in that role. (See Appendix C for an overview of the Analytic Agenda.)

In the past few years, the Department has created a robust set of products, processes, and authorities for developing joint scenarios and data: the Analytic Agenda. The overarching purpose of the Analytic Agenda is to:

Institute a comprehensive and systematic process to provide data for strategic analyses, using approved scenarios and ensuring that data are available, easily accessible, integrated, pedigreed, sufficiently detailed, and synchronized with Planning Programming and Budget System cycles.²³

At the center of scenario development in the Analytic Agenda are the DPSs. These scenarios are developed by OSD (Policy) and serve as extensions of strategic planning guidance. According to OSD, DPSs are designed to:

[Support] analyses that help ‘build a portfolio of capabilities that is robust across the spectrum of possible force requirements, both functional and geographic’ (QDR 2001) [with] variation in threat, Blue/Green capabilities, force size, composition, [and] technological sophistication.²⁴

Figure 4.5 distills a few key objectives for the Analytic Agenda from these statements and presents a broad assessment of the Analytic Agenda’s performance to date along these dimensions. The general implication is that the Analytic Agenda has achieved considerable progress in implementing its objectives, but opportunities to make significant improvements still remain. Improvements suggested here can be grouped into three topic categories: the breadth of the available set of scenarios; the scenario selection process; and scenario timeframe considerations.

Objective for AA and DPSs	Achieved?	Comments
Comprehensive and systematic process using approved scenarios	YES	<ul style="list-style-type: none"> Functioning process in place for production, coordination, dissemination of joint DPSs, MSFDs, Analytic Baselines Major joint analyses use these products extensively
Data are available, accessible, etc.	YES	<ul style="list-style-type: none"> OSD/PA&E/Joint Data Support is effective in providing data accessibility, transparency, etc.
Robust across spectrum of force requirements	PARTIAL	<ul style="list-style-type: none"> Completed scenario set does NOT cover full range of military operations (though significant range is covered in SSSP)
Variation	PARTIAL	<ul style="list-style-type: none"> Bounded variable format included in existing DPSs Utilization of DPS variability has been limited Current policy initiatives may eliminate bounded variable format from DPSs

Figure 4.5: Status Assessment of Analytic Agenda Scenario Development

The issue of scenario set breadth is directly relevant to the one remaining unaddressed dilemma of joint mission analysis management. Dilemma #4 is that uncertainty in the strategic and tactical environments demands analysis across a wide range of variability in threats and environmental parameters; but senior leaders must have some common framework with which to adjudicate competing claims based on multiple analyses emphasizing different variables. One solution to this dilemma is simply to complete the full implementation of the Analytic Agenda as originally envisioned and described above.

Currently, OSD (Policy), in close consultation with other key components, determines how many DPSs will be developed, which scenarios will be developed, and in which order they will be developed.²⁵ This determination is made based on a variety of factors, including the interests of senior leadership, coverage of a full range of military operations (ROMO), and input from various DoD components. However, the current scenario set does not provide full coverage of the ROMO. Issuance of the forthcoming “Steady-State Security Posture” (SSSP, formerly the “Baseline Security Posture” (BSP)) scenario will partially mitigate this deficiency, though the exact nature of the document is still emerging at the time of this writing. Expansion in breadth of the scenario set is limited by a relatively long and labor-intensive development process. Completion of both DPSs and their associated Multi-Service Force Deployment documents (MSFDs) takes approximately nine months.

The following are options to address these challenges:

Option 4-M: Expand DPS set to cover the full range of military operations.

Description: Expand mid-term DPS set using current format and process to ensure complete ROMO coverage.

Pros: Makes detailed, Department-wide, standardized, coordinated, and approved assumptions and data available for all analyses of major planning and programming issues.

Cons: Requires allocation of added time and resources for scenario development.

Option 4-N: Vary level of detail in DPSs according to priority or nature of analysis to be conducted.

Description: Create DPSs with different levels of detail, analogous to levels of plans described in the CPG, depending on priority or nature of the operational challenge depicted. This could include covering some mission types in the SSSP scenario only. (This option is currently under consideration by OSD (Policy).)

Pros: Increases scenario and data production throughput without significant additional investment of resources; enables leadership to tailor focus within the scenario set according to strategic priorities.

Cons: Reduces standardization and fidelity of assumptions and data that are available; may shift some data development work back to individual study efforts.

A related area for potential improvements is the process by which scenarios are selected. Currently, DPS selection and prioritization occurs on an ad hoc basis and is subject to frequent change. The most recent initiative that addressed this challenge was a tasking to OSD (Policy) in SPG 08-13 to provide a proposed scenario list for the

Secretary's approval. In a separate initiative, OSD (Policy) has proposed a new process for scenario selection that would involve more frequent senior leadership engagement, but would not make the timing of selection and prioritization any more regular.

The following are options related to this challenge:

Option 4-O: Retain current process for DPS selection and prioritization.

Description: OSD (Policy) develops, for the Secretary's approval, a list of scenarios to be developed, and the order in which they will be developed.

Pros: Retains full flexibility for senior leadership in exercising control over Analytic Agenda priorities.

Cons: Limits the alignment of DPS selection and prioritization with other processes and decision points; inhibits effective participation in process of other components.

Option 4-P: Routinize the selection of DPS sets to align with key decision points.

Description: Routinize and regularize the timing and process for selection of DPS sets to align with key decision points in planning processes.

Pros: Increases transparency and allows other planning processes to anticipate timing of DPS selection; allows outputs of other planning processes to influence DPS selection and prioritization decisions.

Cons: Decreases flexibility and responsiveness of DPS selection to senior leader concerns and emerging world events.

Option 4-Q: Fully implement published guidance to revise or replace DPSs on a two-year cycle.

Description: Implement guidance already in DoDI 8260.2 to develop and/or update scenarios for strategic analysis at least every two years.²⁶

Pros: Analyses benefit from best available intelligence and most current concepts relevant to scenarios.

Cons: Resources dedicated to updating existing scenarios are not available to develop new scenarios, data, or analyses.

The final set of options offered here relates to the distribution of Analytic Agenda products across different planning timeframes. The original guidance for the Analytic Agenda identified three relevant timeframes and asserted that "we must evaluate the issues in three time frames using different means."

- "Near Term: War plans and associated force readiness
- End of FYDP: DPG scenarios that extend war planning cases to the end of the FYDP, focus on force *capabilities*, and decisions on Defense program issues (programs to implement postulated capabilities) [emphasis in original]

- Far term: Plausible planning cases (mission + threat + capabilities) where capabilities are determined by long range acquisition issues and current investments in S&T”²⁷

Defense Planning Scenarios and MSFDs were intended to address the “End of FYDP” (referred to here as “mid-term”) and the “far-term” timeframes. Today, as intended, no scenarios are developed for the near-term timeframe (inside the FYDP). Instead, the Joint Staff and COCOMs are responsible for building Current Year Analytic Baselines (CYABs) based on analyses of current operation plans directed by the CPG and SCG.²⁸ Currently, management of analysis of current war plans is highly decentralized and COCOMs have limited analytic capacity for development of these CYABs.

Most DPSs (and associated MSFDs and Future Year Analytic Baselines (FYABs)) are developed for the mid-term timeframe (FYDP+1). Current war plans are one of many types of inputs to mid-term scenario selection and content, but leadership intent for the relationship between war plans and mid-term scenario development is not explicit in terms of scenario selection, content, and analysis.

Some DPSs (and associated MSFDs and FYABs) are produced for the far-term time frame and contain the same format and detail as mid-term scenarios and data.

Given these characteristics of the current Analytic Agenda products, the following options are aimed at improving the alignment of those products and the three different planning timeframes addressed.

Option 4-R: Increase emphasis on analysis of near-term capabilities issues.

Description: Expand analytic resources and management attention given to analysis of current plans and current forces. Develop processes for capturing COCOM mission analyses that inform the CYAB.

Pros: Comprehensive analytic view of all current plans supports multiple areas of decision-making (readiness, risk assessment, IPLs) and establishes a baseline for comparing capability portfolio choices.

Cons: Requires additional resources or shift of resources from existing activities.

Option 4-S: Enhance coordination between near-term war plans and mid-term scenario development.

Description: Clarify intent and decision rules for differences in priorities and content between war plans and mid-term scenario development (this is a current OSD (Policy) initiative).

Pros: Improves ability to understand return on investments through comparisons over time; improves ability to understand operational vs. future risk trade-space.

Cons: COCOMs may resist efforts to expose the CONOPS on which their war plans are based.

Option 4-T: Broaden far-term scenarios to include consideration of alternative futures.

Description: Redirect far-term scenario development to include broader depictions of multiple alternative futures rather than detailed depictions of a single threat and operating environment.

Pros: Alternative futures that take into account a range of uncertainty are better suited for providing context to science and technology (S&T) planning, assessing policy and program robustness, and developing hedging strategies than are detailed depictions of threat and operational environment (though these are still required to support AoAs/EoAs for systems with long development lead times, which illustrates a fundamental problem in the agility of programming and acquisition processes).

Cons: Requires additional resources or shift of resources from existing activities.

Joint Concept Development & Experimentation

Joint concepts are the second key ingredient of mission analysis. From concepts embedded in the joint doctrine that serves as the basis for operation plans (OPLANs) to transformational concepts for the employment of yet-to-be developed technologies, joint concepts are drivers of capabilities development. The CPG and SPG provide in the near term, and DPSs provide in the mid- and far term, *what* military forces must be prepared to do; joint concepts describe the *how*.

JCD&E that supports capabilities development planning can and does take different forms depending on the nature and the time frame of the problem being addressed. The discussion that follows identifies areas where current JCD&E practices could be improved to better support capabilities development planning processes and decisions.

When Concepts are Necessary. General Donn A. Starry, principal architect of the Air-Land Battle concept that transformed the Army after Vietnam, identified three circumstances that generate the need for a new concept:

1. Recognition of a problem for which current or programmed capabilities are insufficient;
2. Recognition of a new mission for which no capability exists;
3. New or improved technology having military application, not yet exploited.²⁹

Based on these criteria, concept development depends on being able to (1) analyze the adequacy of programmed capabilities to accomplish all the tasks required by missions currently assigned; (2) identify new missions that military forces will be called upon to perform, together with the new capabilities that will be needed to accomplish them; and (3) understand the military potential of technologies that are not yet mature, and devise ways to exploit them.

Strategic Guidance for Developing and Using Future Joint Concepts. The 2001 QDR called for a transformation of US forces based on operational concepts and capabilities. The QDR established four pillars of transformation – one of which was “experimenting

with new approaches to warfare, operational concepts and capabilities, and organizational constructs . . . through wargaming, simulations, and field exercises focused on emerging challenges and opportunities.”³⁰ The DPG for Fiscal Years 2004-2009 subsequently tasked the Under Secretary of Defense for Policy to prepare Transformation Planning Guidance for the Secretary’s approval.³¹ The TPG, issued by Secretary Rumsfeld in April 2003, described a strategy for implementing transformation. Central to the strategy was balancing the requirements of current operations against investments in capabilities needed to support future operating concepts. This part of the strategy had two elements:

- Reform of the requirements system to better identify and assess specific options for mitigating future risks, to be accomplished by investing in transformational capabilities based on joint operating concepts.
- A transformed analytic capability that accounts for greater uncertainty in threats and capabilities and is capable of comparing risks across time and between multiple theater-level operations.

Declaring that “the key to the Department’s transformation strategy is future joint operating concepts,” the TPG made the Chairman responsible for developing authoritative joint concepts in three timeframes:

- Near-term (2-3 years out) Joint Operations: Current war plans and joint doctrine would be the authoritative baseline against which joint training and experimental results would be measured to assess their transformational value.
- Mid-term (just beyond the FYDP) Joint Concepts: Future joint concepts would depict how the joint force of the future is to fight, addressing specific military operations across the range of military operations. The Chairman was tasked to develop one overarching joint concept and oversee development of four subordinate joint operating concepts (JOCs), addressing homeland security, stability operations, strategic deterrence, and major combat operations.
- Far-term (15-20 years out) Joint Vision: The Joint Vision document (Joint Vision 2020, published in June 2000) would be modified and used as a long-range articulation of joint operations, providing a broad statement of desired future concepts and capabilities required for future operations. The Joint Vision also would provide the context for future joint and Service concept development and experimentation.³²

Soon after this guidance was published, joint concepts were pushed much farther into the future. The “overarching joint concept,” dubbed the Joint Operations Concepts (JOPsC), was approved in November 2003. It described “how the Joint Force intends to operate within the next 15 to 20 years” – the same time horizon the Joint Vision was supposed to occupy, according to the TPG.³³ The four subordinate JOCs, published between February and September 2004, were similarly “focused on the time horizon just beyond the FYDP, roughly 2015.”³⁴ As those concepts were being produced in 2004, FYDP 2006-2011 was being prepared for submission to Congress in February 2005. FYDP 2008-2013 was still in the future, to be submitted in February 2007. FYDP 2010-2015 will not be submitted to Congress until February 2009. Instead of “just beyond the FYDP,” the first round of joint concepts was set three FYDPs into the future. In May

2004, the Joint Vision effectively disappeared when the Chairman signed a new NMS that, a footnote said, “integrates the document formerly known as ‘Joint Vision.’”³⁵

CJCSI 3010.02B, published in January 2006, provided guidance for joint concept development, and pushed joint concepts even farther into the future:

Anyone in the joint concept community can propose ideas for new concepts. The initiation of new concepts may result from policy and or strategy changes, lessons learned, or insights and/or results from joint experimentation. To be considered, ideas or concepts must describe a particular military problem, 8 to 20 years in the future, for which there is currently no adequate military solution.³⁶

Consistent with this guidance, a new overarching joint concept replaced the JOpsC in August 2005. Now named the Capstone Concept for Joint Operations (CCJO), it “heads the family of joint concepts [the term to which the acronym JOpsC now applies] that describe how joint forces are expected to operate across the range of military operations in 2012-2025 in support of strategic objectives.”³⁷ The JOpsC family of joint concepts now spans both the “mid-term” and “far-term” time horizons envisioned in the TPG. Elsewhere, as noted in Chapter 2, other sub-elements of CBP ascribe different meanings to “near-, mid-, and far-term.”

No explanation has ever been given for why joint concepts were pushed from just beyond the FYDP, where presumably they would influence the programs approved for the next FYDP submission two years hence, to as far as 20 years in the future. Twenty years is longer than it took to go from the Wright brothers’ first flight (1903) to Billy Mitchell’s sinking of a German battleship (1921), or about the same time it took from the first catapult launch from the USS Langley (1922) to the Battle of Midway (1942). Twenty years is roughly the time elapsed since the first stirrings of the public Internet to today (the worldwide web didn’t come along until the early 1990s). A joint concept written in 2006 provides, at best, a hazy view of warfare circa 2026, especially at a time when, as declared in the NDS, “Uncertainty is the defining characteristic of [the] strategic environment.”³⁸ Trying to base military requirements on such a distant view of the future carries a risk of committing too soon to a set of capabilities that may not be quite what is needed when the time comes to use them.

The Family of Joint Concepts. The JOpsC family consists of four types of concepts, each with a distinct purpose as follows:

Capstone Concept for Joint Operations – The CCJO is the overarching concept of the JOpsC family that guides the development of future joint capabilities. The purpose of the CCJO is to lead force development and employment by providing a broad description of how future joint forces are expected to operate across the range of military operations 8-20 years into the future. Service concepts and subordinate joint operating, functional, and integrating concepts will expand on the CCJO solution.

Joint Operating Concept – A JOC applies the CCJO solution in greater detail to a specified mission area, describing how a joint force commander, 8-20 years into the future, is expected to conduct operations within a military campaign. It identifies the operational level effects considered essential for achieving the end states envisioned by the concept and focuses on the broad military capabilities necessary

to create those effects. JOCs provide the operational context for the development of joint functional and joint integrating concepts. The four JOCs published to date were all produced by COCOMs; a fifth, on Irregular Warfare, is being co-produced by USSOCOM and the Marine Corps.³⁹

Joint Functional Concept – A JFC applies elements of the CCJO solution to describe how the joint force, 8-20 years into the future, will perform an enduring military function across the full range of military operations. It identifies the operational-level capabilities needed to support the range of military operations and the key attributes necessary to compare alternatives. JFCs also determine any additional military capabilities required to create the effects identified in JOCs, and provide operational context for development of JOCs and joint integrating concepts. FCBs chartered by the JROC are responsible for JFC writing, development, and assessment. The JROC establishes FCBs according to functional areas, and the Vice Director, J-8 approves FCB portfolios within each functional area. There are currently eight JFCs, each corresponding to, and maintained by, an established FCB. FCBs continually assess their JFCs and relationships with other concepts.⁴⁰

Joint Integrating Concept (JIC) – A JIC is an operational-level description of how a joint force commander, 8-20 years into the future, will perform a specific operation or function derived from a JOC or a JFC. JICs are narrowly scoped to identify, describe, and apply specific military capabilities, decomposing them into fundamental tasks, conditions, and standards. Further analyses and expansion of tasks, conditions, and standards is accomplished after JIC completion in order to effectively execute a CBA. Additionally, a JIC contains illustrative vignettes to facilitate understanding of the concept.⁴¹

Use of Joint Concepts in JCIDS. The CJCSI on concept development explains the relationship of the JOpsC family to JCIDS as follows: “Military capabilities derived from JOpsC family development may be entered into the JCIDS analysis process to determine gaps, redundancies, and potential DOTMLPF and policy solutions.”⁴² To understand what that might mean, it is necessary to see what JCIDS directives say about the role of joint concepts in the JCIDS analysis process.

CJCSM 3170.01B describes the JCIDS analysis process as a “capabilities-based assessment (CBA) composed of a structured, four-step methodology that defines capability gaps, capability needs and approaches to provide those capabilities within a specified functional or operational area.”⁴³ The four prescribed steps of a CBA are an FAA; an FNA; an FSA; and a Post Independent Analysis (PIA). The requirement for a PIA was subsequently removed by a JROC Memorandum, so the discussion here will address only the FAA, FNA, and FSA.⁴⁴

The JCIDS manual says a JCIDS analysis begins when a COCOM, FCB or sponsor (defined as the DoD component responsible for funding actions to support acquisition – i.e., a Service, agency, or COCOM (such as USSOCOM) with its own budget and acquisition authority, but not a geographic COCOM) leads performance of an FAA. The FAA can be self-initiated by a sponsor or COCOM based upon an approved CONOPS, or it may be initiated at JROC direction based upon the family of joint future concepts.⁴⁵

There is obviously a distinction between a CONOPS and a future joint concept, and the distinction is worth exploring.

A CONOPS is officially defined as:

A verbal or graphic statement, in broad outline, of a commander's assumptions or intent in regard to an operation or series of operations. The concept of operations frequently is embodied in campaign plans and operation plans; in the latter case, particularly when the plans cover a series of connected operations to be carried out simultaneously or in succession. The concept is designed to give an overall picture of the operation. It is included primarily for additional clarity of purpose. Also called commander's concept.⁴⁶

Doctrine for planning joint operations uses the term concept of operations or CONOPS to describe the "CINC's Strategic Concept" – the end product of the concept development phase of deliberate planning, which is submitted to the CJCS for review and approval. In the plan development phase, the CJCS-approved CONOPS is expanded into a complete OPLAN.⁴⁷ From this discussion, it seems evident that the "approved CONOPS" that may be used by a sponsor or COCOM as the basis for a self-initiated FAA refers to the CJCS-approved CONOPS associated with a contingency plan.

For purposes of JOpsC family development, however, CONOPS have a different connotation. CONOPS used in the joint concept development process are based on (and integral to) DPSs and MSFDs. These scenarios have classified CONOPS that provide a high level of specificity and defined parameters to aid in robust analysis of capabilities and a comparison of alternate solutions. The CONOPS are used to provide overall understanding of an operation and the broad flow of tasks assigned to subordinate and/or supporting entities, presenting a joint force commander's plan that synchronizes military capabilities to accomplish the mission for a specific scenario 8-20 years into the future.⁴⁸

As they relate to JCIDS, CONOPS have still a different meaning and use. The JCIDS instruction specifies that the JOpsC family is used to underpin investment decisions leading to the development of new capabilities beyond the FYDP. New capability requirements, materiel or non-materiel, must relate directly to capabilities identified through the JOpsC family, whose hierarchical nature and deliberate process require close examination of needed capabilities through an iterative process of assessment. Therefore, within JCIDS, joint future concepts are not intended to provide immediate solutions but proposed solutions that can afford careful examination over a more extended period of time. For the near-term, which the JCIDS instruction defines as now to seven years in the future, CONOPS and joint tasks allow the joint community to adjust or divest current capabilities by providing the operational context needed to substantiate current programs.⁴⁹

To summarize, JCIDS analysis within the near term, now to seven years in the future, uses CJCS-approved CONOPS associated with COCOM OPLANs, while beyond seven years, CONOPS associated with DPSs, and based on future joint concepts, are used.

The CJCSM for JCIDS operation says that:

An FAA . . . uses, as input, the national strategies, the Family of Joint Future Concepts, CONOPS, joint tasks, the capabilities list (e.g., Universal Joint Task List), the anticipated range of broad capabilities that an adversary might employ and other sources.⁵⁰

The CJCSI adds “UCP-assigned missions” to this list of FAA inputs.⁵¹ Both directives list the JOpsC family as inputs to an FAA, but neither specifies which concepts are used – JOCs, JFCs, or JICs. The CJCSM goes on:

The Family of Joint Future Concepts and other sources provide a list of capabilities and associated operational conditions. The FAA identifies the scenarios against which the capabilities and attributes will be assessed. Scenario sources include, but are not limited to, DPSs published by OSD. This capabilities list is then scoped to make the analysis conducted during the FAA manageable.⁵²

The CJCSM says “the output of the FAA is the list of capabilities and their associated tasks and attributes,” while the CJCSI says “the FAA produces a prioritized list of capabilities and tasks across all functional areas necessary to achieve the military objectives,” and that “the capabilities and their attributes should be traceable to the Family of Joint Future Concepts and any other supporting information used to develop the capabilities.”⁵³ Herein lies a fundamental disconnect. The CJCSI says the FAA produces a list of capabilities across all functional areas, while the CJCSM says the capabilities list is scoped down to make the FAA manageable. An FAA for which the capabilities list is scoped down does not cover even one functional area, much less all. As noted above, the JROC uses “functional areas” as the basis for establishing FCBs. If these same functional areas are not the basis for a functional area assessment, what is?

Discrepancies between the JCIDS Instruction and Manual also exist with respect to the FNA. According to the CJCSM, “Using the tasks identified in the FAA as primary input, the FNA produces a list of capability gaps that require solutions, and indicates the time frame in which those solutions are needed.” According to the CJCSI, “Using the capabilities and tasks identified in the FAA as primary input, the FNA produces a list of capability gaps that require solutions, and indicates the time frame in which those solutions are needed,” and that “It may also identify redundancies in capabilities that reflect inefficiencies.”⁵⁴ One says the primary input to the FNA is tasks, the other says it is tasks and capabilities. But what does “capabilities” really mean in this context – capabilities that exist today, or that will result from approved programs over the FYDP? Capabilities that do not yet exist but would be needed to execute a joint future concept? The meaning is not clear, but can be inferred from the fact that the output of an FNA is a list of capability gaps and, perhaps, also redundancies: if gaps and redundancies are the output, then the inputs can only be the tasks identified during the FAA and the capabilities that exist or are in the approved program. In the simplest terms, the FNA compares the things military forces have to do (tasks) to the capabilities available to do them, and concludes that (1) the capabilities are about right, (2) there are tasks for which no capability exists or is programmed – these are the gaps, or (3) there are tasks for which more than enough capability exists – these are the redundancies, or excesses, or “areas where risk can be accepted.”

Since by definition a JOC applies the CCJO solution to a specified mission area, and a JFC describes how the joint force will perform a military function across the full range of military operations, it seems logical that an FAA would be a mission analysis of a JOC or across all JOCs (assuming that together they represent the full range of military operations) to determine the set of tasks a particular functional area would have to perform. An FNA would then compare that set of tasks to the full set of capabilities that either

already exist or are programmed to exist at some date in the future to determine gaps and redundancies. To fulfill the purpose outlined here, JOCs would need to be written at a greater level of detail that permits clear identification and prioritization of critical effects and the capabilities needed to achieve those effects. (The Defense Planning Scenarios do appear to have the level of detail required to support this level of analysis, but they are more narrowly cast, applying JOCs to specific geography and a specific threat, and are thus especially well-suited for level-2 analysis.)

JFCs are developed, assessed, and maintained by FCBs, which the JROC establishes by functional area. Since a JFC is a description of how the joint force will perform a function across the range of military operations, it follows that a JFC ought to describe the full set of tasks to be performed within its FCB's assigned functional area, how the existing or programmed capabilities within that functional area contribute to accomplishment of those tasks, and it ought to identify which tasks cannot be accomplished by applying existing or programmed capabilities. This is essentially the description of a holistic FAA and FNA.

What role, then, should JICs play in JCIDS analysis? A Joint Staff (J-8) White Paper on Conducting a CBA describes the current process this way: "The FAA synthesizes existing guidance to specify the military problem to be studied. The FNA then studies the problem, assesses how well DoD can address the problem given its current program, and recommends needs the DoD should address. The FSA takes this assessment as input, and generates recommendations for solutions to the needs."⁵⁵

Under current JCIDS directives, JICs would therefore be inputs to the FSA, defined as "an operationally based assessment of all potential DOTMLPF and policy approaches to solving (or mitigating) one or more of the capability gaps identified in the FNA."⁵⁶ Each JIC would describe in detail a specific combination of DOTMLPF elements and how that combination would accomplish the task or tasks for which no capability exists or is programmed to exist. Under the three-level analytic scheme proposed in this report, the FAA and FNA would be level-1 analyses conducted by FCBs across their assigned functional areas. What are now called the FAA and FNA portions of a CBA would be performed as level-2 assessments of specific issues and gaps identified in the FNA. What are today called FSAs would continue to be performed as level-3 solution development activities. Where level-2 capability assessments suggest the need for new concepts using the General Starry criteria discussed previously, JICs would be developed and subjected to experimentation and other forms of assessment.

Joint Experimentation to Refine and Validate Joint Concepts. The Chairman's guidance on JCD&E says that "joint experimentation is primarily conducted on the CCJO, JOCs, and JFCs," and that while JICs may also require joint experimentation to further refine or mature them, "they are primarily evaluated through a CBA." Moreover, the CCJO, JOCs and JFCs are revised on a regular cycle, while "JICs are only revised as directed."⁵⁷

This experimentation scheme seems inverted. The CCJO, JOCs and JFCs are broad concepts best evaluated through an assessment process supported by wargaming – a form of experimentation, but not one likely to lead directly to new capabilities. Once the FCBs complete level-1 assessments and the JROC prioritizes issues across FCBs, and level-2 analysis of those priority issues identifies the priority problems to be solved, all

DoD components should be invited to submit JICs describing proposed approaches to satisfying those needs. Joint experimentation would then be used to assess and compare alternative approaches, to support subsequent development and integration of the JROC-recommended solutions.

Once a JIC or, preferably, competing JICs have been vetted and approved for level-3 analysis, JFCOM or another sponsor should develop experimental articles or prototypes, or use surrogates, to experiment – to tinker with the proposed combinations of DOTMLPF to find out what does and does not work, and to validate or disprove the concept. Currently, this “concept refinement” phase of the acquisition process rarely involves experimentation, but is based solely on analysis; empirical evidence from experimentation would inform the analysis, and hands-on trials by experienced operators would help assure the necessary co-evolution of organization, training, and doctrine (tactics, techniques, and procedures) with the developmental materiel item. JICs should be revised continuously based on the results of analysis and experimentation and archived only when the problem they were developed to solve has, in fact, been solved – when the capability gap has been mitigated to the point that it no longer is an issue.

The Technological Dimension of Joint Concept Development. The third of General Starry’s circumstances that might generate the need for a concept was “new or improved technology having military application, not yet exploited.” Under current processes, future joint concepts and capability needs are not shaped by an informed understanding of future technological possibilities.

The Director of Defense Research and Engineering (DDR&E) develops science S&T plans in three time frames: Basic Research Plan – time horizon 20-25 years; Defense Technology Area Plan – 5-20 years; and Joint Warfighting Science and Technology Plan – 5 years or less. The DTAP makes repeated references to Service and joint concepts to which technology programs appear to apply, and the JWSTP is organized completely around JFCs. There is thus abundant evidence that the JFCs are exerting “operator pull” on both the DTAP and the JWSTP, but no evidence that the DTAP or any other S&T plan is exerting “technology push” on future joint concepts.

Of eight JFCs, only one – Battlespace Awareness – even makes any reference to the DTAP (one time, in a footnote, but not in the bibliography).⁵⁸ The CJCSI on joint concept development lists “the proper military-technological context” as a consideration when writing a concept, explaining that “concepts are designed to exploit new technologies or to respond to the proliferation of new technologies,” but neither the directive nor any of the templates it contains – for the CCJO, JOCs, JFCs, or JICS – requires any explicit consideration of the technologies that might be applicable to the time frame or the missions or the functions addressed by joint concepts.⁵⁹ Enormous effort is being expended to develop future concepts that do not take into account the possibilities raised by billions of dollars in S&T investment.

Capabilities consist of far more than just technology; in fact, technology underpins just one element – materiel – of a capability. Failing to incorporate technological possibilities into future concepts only delays the development of needed capabilities.

The following are options related to the challenges addressed above.

Option 4-U: Separate mid-term from far-term in joint concepts.

Description: Use mid-term concepts (just beyond the FYDP) to conduct FAAs and FNAs based upon the approved programs in the current FYDP, also known as the “programmed force.” Create separate concepts or vision documents for the far term, emphasizing new missions or tasks that might emerge and emphasizing as well the technological possibilities that could be exploited in the future to change the way we do things now or enable us to do things in the future we cannot do “now” (i.e., with the programmed force).

Pros: Tailors mid-term concepts more closely to needs for mid-term analyses; retains forum for longer-term perspective in concept development and “discovery.”

Cons: Would require revision and reorientation of existing concepts and “family of concepts” structure.

Option 4-V: Distribute JCD&E resources and attention among level-1 far-term exploration of alternative strategic and operational concepts, prioritized level-2 “problems to be solved,” and level-3 concept refinement.

Description: Over the past several years, the emphasis in the JCD&E plan has swung from far-term, high-level concepts – like Rapid Decisive Operations – to near-term focus on countering improvised explosive devices (IEDs). Efforts should be made to focus the efforts on MPMI and balance expenditures among the three levels of JCD&E.

Pros: Makes JCD&E more relevant to DoD capabilities development decisions; involves COCOMs more fully in JCD&E by addressing their issues that result in MPMIs.

Cons: Will require greater Pentagon and COCOM oversight of JCD&E plan priorities.

Option 4-W: Use DPSs in the place of JOCs in capability-based analysis.

Description: A specified set of DPSs would provide the context for a revised level-1 FCB FAA/FNA process.

Pros: Eliminates JOCs that have consumed many man-years but have not produced much value; uses in their place National Military Strategies for WOT, Combating WMD, Cyberspace, etc.; covers greater range of operations.

Cons: The community that has formed around JOCs will resist change.

Option 4-X: Develop routine practice of experimentation in joint training and COCOM exercises.

Description: Routinely evaluate new DOTMLPF solution concepts in joint training and COCOM exercises.

Pros: Allows iterative evaluation of DOTMLPF concepts, and facilitates rapidly bridging priority capability gaps through user-developer concurrent development; promotes adaptation of forces to new circumstances. Allows rapid feedback to JIC

authors, replaces consensus solutions to “staffing issues” with empirical evidence from field trials.

Cons: Need to balance experimentation with training requirements.

Option 4-Y: Strengthen links between JCD&E and S&T planning.

Description: Revise concept templates in 3010.01B to require explicit consideration of future technologies; realign S&T plans from “technology areas” to JCAs; make JWSTP panel chairs full members of associated FCBs.

Pros: Helps identify technologies with the greatest promise; shapes S&T investment to hasten maturation of technologies with greatest utility; switch to JCAs puts S&T focus on capabilities vice platforms, facilitates common lexicon and data sets, fits better with portfolio approach.

Cons: Requires more extensive collaboration; further stretches already thin S&T manpower (two officials in DDR&E currently chair three JFC panels each).

Also see **Option 4-J** above.

Emerging Issues in Defense Acquisition

This section provides a discussion of emerging issues in defense acquisition that likely will result in revisions to acquisition policies and procedures. The first section describes some of the proposed defense reforms being considered as a follow-on to the QDR. The second section discusses a new approach to defense acquisition known as portfolio management. The third section provides a range of acquisition management options for dealing with the integration of systems of systems.

Issues in the Defense Acquisition Performance Assessment

The 2006 QDR Report suggests that the year will bring significant changes to current defense acquisition policies and procedures. The following extract from the report illustrates the point.

There is a growing and deep concern in the Department of Defense’s senior leadership and in the Congress about the acquisition process. This lack of confidence results from an inability to determine accurately the true state of major acquisition programs when measured by cost, schedule and performance. The unpredictable nature of Defense programs can be traced to instabilities in the broader acquisition system. Fundamentally reshaping that system should make the state of the Department’s major acquisition programs more predictable and result in better stewardship of the U.S. tax dollar. There are several ongoing reviews of defense acquisition improvements being conducted both within and outside the Department in an effort to address those issues. Their results will inform the Department’s efforts to reshape defense acquisition into the truly 21st century process that is responsive to the joint warfighter. The Department of Defense is focusing on bringing the needed capabilities to the joint force more rapidly, by fashioning a much more effective acquisition system and associated set of processes.⁶⁰

One important outside review (authorized by the Deputy Secretary of Defense in June 2005) was the Defense Acquisition Performance Assessment (DAPA) Project. The

task assigned to the project was to consider every aspect of acquisition and to develop a recommended acquisition structure and process with clear alignment of responsibility, authority, and accountability.⁶¹

Our understanding is that the DAPA Project recommendations are being evaluated within the Department by one of the QDR Execution Roadmaps—namely, the DoD Institutional Reform and Governance Roadmap. Some of the changes that may emerge from the Roadmap are shown in Table 4.1.

One specific change being considered concerns the possible merger of the JCIDS Functional Solution Analysis (supporting the Concept Decision) and the Analysis of Alternatives (conducted during the Concept Refinement phase in advance of the Milestone A approval). The new analysis, known as the Evaluation of Alternatives (EoA), would be conducted before the Concept Decision. The guidance for the EoA would blend oversight from all three major decision support processes: capabilities needs, acquisition, and PPBE.

Reform	Description
Capital Account for Major Defense Acquisition Programs (MDAPs)	Establish capital account management process for all MDAPs
Time-Defined Acquisition	Give schedule increased emphasis in the program decision process
Create Risk-Based Source Selection Process	Define appropriate weighting criteria for capability, cost, and past performance in the source selection process
Integrate Requirements, Acquisition and PPBES processes	Design and implement a corporate decision process for force development that integrates the 3 processes at the solution stage of the decision making process
Implement a Continuous Decision Making Process	Recommend changes to current decision making and tracking processes in order to enable issues to be teed up and decided upon at their natural point—facts available and analysis complete vice schedule driven
Strategic and Tactical Acquisition Reform	Develop a specific course of action for implementing improvements to Acquisition set out in the USD(AT&L) Goals and Objectives

Table 4.1: Defense Acquisition Performance Recommendations

Issues in Portfolio Management

The QDR stressed the need to view acquisition as portfolios of joint capabilities rather than as individual stove-piped programs. This emerging initiative appears to be one aspect of the desire to achieve greater unity between the joint warfighting, acquisition, and resource communities. The important extract from the QDR Report is shown below:

Aligning Authority and Accountability through Joint Capability Portfolios

Most of the Department's resources are provided through the Military Services. This arrangement can lead both to gaps or redundancies within capability areas as each Service attempts supply a complete warfighting package rather than organize to depend on capabilities provided by other Military Departments. To optimize the provision of capabilities for the joint warfighter, the Department will work to re-orient its processes around joint capability portfolios. In the acquisition realm, the Department has already instituted several joint capability reviews.⁶²

The exact nature of the implementation of portfolio management within the Department is still emerging at the time of this writing. The Department is proposing to establish a corporate board—jointly chaired by the VCJCS, USD(AT&L), and D(PA&E)—that synthesizes senior leadership decisions for requirements, acquisition, and programming. The corporate board or boards would assess the overall DoD modernization program (perhaps annually), seeking balance among the portfolios that comprise the overall modernization program, and shaping the JPG for service/agency POMs and budgets. In addition, the corporate board or boards would conduct capability area reviews of individual portfolios, seeking balance within each portfolio, and providing guidance to individual programs through some kind of corporate decision memorandum (that would be tied to subsequent decision documents such as a JROC Memorandum, Acquisition Decision Memorandum, or Program Decision Memorandum). In addition, the portfolio capability area reviews would identify and adjudicate any systems of systems or family of systems issues, if need be. However, acquisition milestone decisions for individual programs would be retained within the current Defense Acquisition Board / Information Technology Acquisition Board framework.

It also is possible that, in some cases, entire portfolios would be assigned to a single lead service or agency, or possibly some new type of joint entity, as the Executive Agent for the entire portfolio. The lead entity would establish a structure for overall programming/budgeting authority for the programs within the portfolio. In addition, the lead entity would designate an acquisition official accountable for overall program management for the entire portfolio.

Whatever guidance eventually emerges regarding portfolio management would clearly need to be incorporated in any efforts to revise Department planning processes such as those addressed in this report.

One important issue that should be addressed in portfolio management is the need for more compatible lexicons and data structures among the various domains of capabilities development planning. It is important to be able to translate advice or decisions in one domain into measurable actions in other domains. JCIDS typically is based on families of joint concepts and joint capability areas; acquisition is based on

programs and systems; and PPBE is based on program elements for planning and programming, and budget activities and line items for budgeting and execution. In addition, military capabilities are often assessed in terms of military organizations (perhaps based on unit identification codes). Currently, there is no well-defined crosswalk across these domains and data structures. More progress needs to be made in developing compatible taxonomies among these processes. Ideally, some form of joint capability areas would provide the foundation for the development of such taxonomies, though evaluating the suitability of the current Joint Capability Areas for this purpose was outside the scope of the study reported here.

Improved Integration of Systems of Systems

The fundamental purpose of the JCIDS process is to make recommendations concerning the identification and prioritization of joint military capability needs. Often, a joint military capability need must be addressed through a system of systems (SoS) approach, and not merely through a single materiel solution. CJCSM 3170 provides two important definitions:

system of systems (SoS) – A set or arrangement of interdependent systems that are related or connected to provide a given capability. The loss of any part of the system will significantly degrade the performance or capabilities of the whole. The development of a SoS solution will involve trade space between the systems as well as within an individual system performance.

synchronization – The process of coordinating the timing of the delivery of capabilities, often involving different initiatives, to ensure the evolutionary nature of these deliveries satisfies the capabilities needed at the specified time that they are needed. Synchronization is particularly critical when the method of achieving these capabilities involves a family of systems or system of systems approach.⁶³

However, most of the guidance prescribed in the DoD 5000 series regulations apply to individual system programs, and the regulations do not adequately address the integration of individual systems into a unified whole. Ideally, the acquisition of a system of systems would ensure interoperability and synchronization of program plans for development, procurement, fielding, and sustainment. This presents a difficult challenge, especially if the individual systems are in varying degrees of development or production, if they are assigned to multiple services or defense agencies, or if the various programs are assigned to different milestone decision authorities.

For a system of systems, there should be greater emphasis concerning unity of effort among the various program managers and program executive officers as they prepare and execute their respective acquisition strategies. There also should be more focus on the oversight conducted by OSD and the Joint Staff concerning the development of composite capabilities. In addition, there needs to be more attention to systems engineering, as well as test and evaluation, at the composite system of systems level. Moreover, for cases where some or all of the systems employ evolutionary acquisition, it would be important to synchronize capability delivery schedules across the capability area—to provide coherent overall capability increments.

This section offers three different acquisition management options for a hypothetical system of systems supporting a given joint capability area. The three options

provide increasing degrees of centralized acquisition authority and structure to the management of the composite capability provided by the system of systems. Details on the three options are provided in Table 4.2.

- The first option (labeled Loose Confederation/Centralized Coordination) provides for a formal coordination process among the programs. There are formal Memoranda of Agreement (MOAs) between the various Program Executive Offices (PEOs) and Program Managers (PMs), as well as associate contractor agreements between the various system contractors. There also would be limited OSD and Joint Staff oversight through annual reviews by the appropriate Overarching Integrated Product Team (OIPT).
- The second option (labeled Centralized Guidance/Decentralized Execution) assigns all core⁶⁴ programs in the system of systems to a single Joint Program Executive Officer (JPEO), who provides strategic direction to the core program managers under his or her supervision. The JPEO would be responsible for synchronizing the development, testing, production, fielding, and sustainment of the systems. The JPEO would be provided with a strong, centralized Systems Engineering and Integration Organization (SE&IO) that would develop and maintain a formal SoS architecture, and develop, control, and certify element interfaces within the architecture.
- The third option (labeled Centralized Direction and Execution) would in essence manage the set of core programs as a single MDAP, where the individual core systems are managed as individual projects within the core program. This option provided the greatest degree of technical definition of the SoS architecture, and also provides extensive end-to-end test and evaluation of the system of systems performance relative to the composite capability needs.

Acquisition Management Topics	Loose Confederation/ Centralized Coordination	Centralized Guidance/ Decentralized Execution	Centralized Direction and Execution
1. System of Systems (SoS) Management Structure			
1.1 Program structure	All systems managed as individual programs	All systems managed as individual programs	Core systems managed as composite Program (made of individual projects) Ancillary systems managed as individual programs
1.2 Lead Service/Executive Agent	No lead Service	No lead Service	Core program assigned to lead Service/executive agent
1.3 OSD/Joint Staff oversight	Multiple MDAs Annual Defense Systems/NII OPT review (supported by appropriate FCB)	Core program assigned to single MDA (USD(AT&L) or ASD(NII)) Annual DAB or ITAB review (supported by JROC)	Core program assigned to single MDA (USD(AT&L) or ASD(NII)) Annual DAB or ITAB review (supported by JROC)
1.4 Program Manager (PM) and Program Executive Officer (PEO) structure	Individual PMs Multiple PEOs SoS PEOs establish MOAs for program coordination Limited liaison exchanges between PEOs	Individual PMs Core programs assigned to single Joint PEO Core JPEO establishes MOAs with ancillary PEOs for interfaces and program coordination Small JPEO staff (program oversight)	Core program assigned to single PM Core program assigned to single Joint PEO Core JPEO establishes MOAs with ancillary PEOs for interfaces and program coordination Large JPEO staff (matrix support to projects)
1.5 JCIDS support to acquisition	Individual ICDS/CDDs/CPDs Legacy SoS programs are grandfathered	Individual ICDS/CDDs/CPDs Legacy SoS programs are grandfathered Capstone statement of SoS end-to-end capabilities	Composite ICD/CDD/CPD for core Legacy core elements are not grandfathered Composite statement of SoS end-to-end capabilities

Table 4.2: Acquisition Management Options

Acquisition Management Topics	Loose Confederation/ Centralized Coordination	Centralized Guidance/ Decentralized Execution	Centralized Direction and Execution
2. Evolutionary Acquisition	Individual program decisions PMs exchange information	JPEO develops capstone evolutionary acquisition strategy (and synchronizes individual program activities)	JPEO develops composite SoS evolutionary acquisition strategy (derived from composite capabilities definition)
3. Program Goals and Strategy			
3.1 Acquisition Program Baselines (APBs)	Multiple APBs Programs provide early warning indicators to each other for schedule or performance breaches	Multiple APBs OSD directs that APBs are tightly coupled (no unilateral changes) (enforced by MDA)	Single composite APB for core program OSD directs that APBs are tightly coupled (no unilateral changes) (enforced by MDA)
3.2 Acquisition Strategy	PMs establish subordinate MOAs and associate contractor agreements PMs coordinate fielding and sustainment activities	PMs establish MOAs and associate contractor agreements JPEO hires system integrator (SI) JPEO synchronizes fielding and sustainment activities	Project leaders establish associate contractor agreements JPEO hires lead system integrator (LSI) JPEO directs composite fielding and sustainment for core program, synchronizes with ancillary programs
4. Systems Engineering	PMs establish interfaces through Interface Control Working Groups	JPEO/SI develop and maintain SoS architecture (systems view only) JPEO/SI develop, control, and certify element interfaces JPEO/SI synchronizes configuration management	JPEO/LSI develop and maintain SoS architecture (operational, systems, and technical views) JPEO/LSI develop, control, and certify element interfaces JPEO/LSI establish centralized configuration management

Table 4.2 (cont'd): Acquisition Management Options

Acquisition Management Topics	Loose Confederation/ Centralized Coordination	Centralized Guidance/ Decentralized Execution	Centralized Direction and Execution
5. Test and Evaluation (T&E)	Developmental and Operational (DT&E/OT&E) of individual programs	JPEO prepares capstone SoS T&E Master Plan (TEMP) based on individual program TEMPs (no additional SoS testing)	JPEO prepares composite SoS TEMP with extensive DT&E/OT&E of composite capabilities (derived from composite capabilities definition)
6. Resource Management			
6.1 Service/Agency cost estimates	Individual cost & budget estimates <ul style="list-style-type: none"> • prepared by SoS PMs • reviewed by individual PEOs • presented at annual OIPT review 	Individual cost & budget estimates <ul style="list-style-type: none"> • prepared by SoS PMs • reviewed by JPEO • presented at annual DAB or ITAB review 	Full formal SoS cost & budget estimates (for core plus interfaces to ancillary programs) <ul style="list-style-type: none"> • prepared by JPEO staff • presented at annual DAB or ITAB review
6.2 Independent cost estimates/ full-funding assessments	Individual MDAPs only – Cost Analysis Improvement Group (CAIG) or component cost analysis (CCA) estimates at major program milestones Reviewed by individual MDAs	Individual MDAPs only – CAIG or CCA estimates at major program milestones Reviewed by individual MDAs	Formal SoS independent cost estimates (FFRDC?) Reviewed by MDA at annual DAB or ITAB review
6.3 Affordability assessments	Individual MDAPs and MAISs only OSD reviews at major milestones	JPEO synthesizes annual long-range SoS funding projections (based on inputs from individual programs) Presented at annual DAB or ITAB review	JPEO prepares composite SoS funding projections Presented at annual DAB or ITAB review

Table 4.2 (cont'd): Acquisition Management Options

End Notes

¹ The mission analysis conducted as part of joint operation plan development is described in Joint Pub 5-0, Doctrine for Planning Joint Operations, 13 April 1995, pp. III-3 thru III-6.

² Mission analysis as part of the Joint Training System is prescribed in CJCSI 3500.01C, Joint Training Policy for the Armed Forces of the United States, March 15, 2006, pp. B-1 to B-3.

³ IPLs are defined and discussed in CJCSI 8501.01A, Chairman of the Joint Chiefs of Staff, Combatant Commanders, and Joint Staff Participation in the Planning, Programming, Budgeting, and Execution System, December 3, 2004, pp. B-3 and GL-3.

⁴ Honorable E.C. Aldridge, et al., Joint Defense Capabilities Study: Improving DoD Strategic Planning, Resourcing and Execution to Satisfy Joint Capabilities, Final Report, January 2004, p. 2-10 (Hereafter referred to as "Aldridge Study").

⁵ CJCSI 3170.01E, Joint Capabilities Integration and Development System, May 11, 2005, p. A-1.

⁶ DoDD 8260.1, Data Collection, Development, and Management in Support of Strategic Analysis, December 6, 2002, Sec. 3.7 (p. 2).

⁷ See Ken Krieg, "Capabilities-Based Planning: The View from PA&E," presentation at MORS Workshop on "Capabilities-Based Planning: The Road Ahead," October 19, 2003, p. 3. Available at http://www.mors.org/meetings/cbp/cbp_presentations.htm

⁸ Leaders of the IR&G effort divide force development decision levels into "strategic choice," for balancing among capabilities, "portfolio choice," for balancing within capability areas, and "weapon system choice," for balancing time, money, performance, and risk within a system. LTG Skip Sharp and Ken Krieg, "QDR Execution Roadmap, Institutional Reform and Governance, Capability-Based Force Development Concept Brief (Continued)," unpublished briefing, February 28, 2006, slide 19.

⁹ LPTR is described in the QDR Report as "an automated process that maps resources needs to discrete operational plans and missions" (p. 67). For additional information, see overview briefing, Michael Fischerkeller, "Linking Plans to Resources (LPTR) Process," March 15, 2006. Available at http://www.dtic.mil/futurejointwarfare/cap_areas.htm

¹⁰ CJCSI 3170.01E, p. A-4.

¹¹ See Institute for Defense Analyses, "Summary of the Strategic Risk Assessment Methodology (RAM) developed for use in Department of Defense strategic planning," unpublished working paper, March 31, 2006.

¹² For examples, see Defense Science Board Summer Study on Transformation: A Progress Assessment (Volume 1) (Department of Defense, February 2006), pp. 7-8; Aldridge Study, Chapter 2.

¹³ Jason Sherman, "Giambastiani Charts New JROC Course, Seeks 'Most Pressing' Needs," Inside the Pentagon, April 27, 2006.

¹⁴ See John T. Hanley and James H. Kurtz, Joint Programming Guidance for Fiscal Years 2006-2011, Institute for Defense Analyses, February 15, 2005.

¹⁵ CJCSI 3170.01E says the FAA identifies the operational tasks, conditions and standards needed to achieve military objectives and produces a prioritized list of capabilities and tasks across all functional areas (p. A-4); and the FNA assesses the ability of the current and programmed warfighting systems to deliver the capabilities the FAA identified under the full range of operating conditions, and produces a list of capability gaps that require solutions and indicates the time frame in which these solutions are needed (p. A-5). It goes on to say that the FAA "may" identify redundancies in capabilities that reflect inefficiencies. This study holds that if the FAA and FNA are correctly accomplished *across all functional areas* as prescribed, they will identify redundancies.

¹⁶ Aldridge Study, Chapter 3.

¹⁷ For a full description of this option, see Christopher J. Lamb and Irving Lachow, Reforming Pentagon Strategic Decisionmaking (Washington, DC: National Defense University) Strategic Forum Paper No. 221, July 2006.

¹⁸ CJCSI 3170.01E, GL-15.

¹⁹ For an overview of the EoA and its role in the Concept Decision review process, see James "Raleigh" Durham, "Concept Decision Implementation," briefing to MORS Workshop on Capabilities Based-Planning, April 2006. Available online at: http://www.mors.org/meetings/cbp_II/briefs/durham.pdf

²⁰ Aldridge Study, p. 2-11.

²¹ CJCSI 3170.01E, p. A-8.

-
- ²² DoDD 8260.1, Sec. 3.1 (p. 1).
- ²³ DoDD 8260.1, Sec. 4.1 (p. 2).
- ²⁴ Briefing from ODASD (Resources and Plans), “Analytic Agenda,” March 25, 2003, slide 6.
- ²⁵ The official guidance on scenario selection is as follows: “The Under Secretary of Defense for Policy, in coordination with the Heads of the DoD Components, shall . . . Develop and establish priorities among scenarios for use by the DoD Components in conducting strategic analyses.” (DoDD 8260.1, Sec. 5.1, 5.1.1)
- ²⁶ “The Under Secretary of Defense for Policy (USD(P)), in coordination with the Heads of the DoD Components, shall . . . Develop and/or update DoD scenarios for strategic analyses at least every 2 years.” (DoDI 8260.2, Sec. 5.2, 5.2.1)
- ²⁷ Briefing from ODASD (Resources and Plans), “Transforming How We Plan: Capabilities-Based Planning and the New Approach to Defense Planning Scenarios,” November 14, 2002, slide 3.
- ²⁸ “The Chairman of the Joint Chiefs of Staff, in coordination with the Heads of the DoD Components, shall develop baselines for use in strategic analyses of current forces, based upon scenario priorities identified by the Under Secretary of Defense for Policy.” (DoDD 8260.1, 5.2)
- ²⁹ General Donn A. Starry, Commander’s Note #3, Operational Concepts and Doctrine, February 20, 1979.
- ³⁰ Quadrennial Defense Review Report, September 30, 2001, pp. 29, 32.
- ³¹ Defense Planning Guidance Fiscal Years 2004-2009 (U), May 2002, pp. 6, 49-50, 53-54.
- ³² Transformation Planning Guidance, April 2004, pp. 8, 15-16.
- ³³ Joint Operations Concepts Paper, November 2003, p. 3.
- ³⁴ Major Combat Operations Joint Operating Concept, September 2004, p. v; Stability Operations Joint Operating Concept, September 2004, p. v.
- ³⁵ The National Military Strategy of the United States: A Strategy for Today; A Vision for Tomorrow, 2004, p. 3.
- ³⁶ CJCSI 3010.02B, Joint Operations Concepts (JOpsC) Development Process, January 27, 2006, p. B-1.
- ³⁷ Capstone Concept for Joint Operations, Version 2.0, August 2005, p. vii.
- ³⁸ The National Defense Strategy of the United States of America, March 2005, p. 2.
- ³⁹ CJCSI 3010.02B, p. A-2; Briefing, “J-7 Transformation and Concepts,” as of July 13, 2006, accessed at the Future Joint Warfare website, <http://www.dtic.mil/futurejointwarfare/>
- ⁴⁰ CJCSI 3010.02B, pp A-2, A-3, E-4 and E-5; CJCSI 3137.01C, The Functional Capabilities Board Process, November 12, 2004, pp. A-2 and C-2.
- ⁴¹ CJCSI 3010.02B, pp A-2 and A-3.
- ⁴² CJCSI 3010.02B, p. A-5.
- ⁴³ CJCSM 3170.01B, Operation of the Joint Capabilities Integration and Development System, May 11, 2005, p. A-1.
- ⁴⁴ JROCM 062-06, cited in “JCIDS Overview” briefing, Joint Staff (J-8) Capabilities and Acquisition Division, July 7, 2006, slide #27.
- ⁴⁵ CJCSM 3170.01B, pp. A-1 and GL-16.
- ⁴⁶ Joint Pub 1-02, DoD Dictionary of Military and Associated Terms, as amended through April 14, 2006.
- ⁴⁷ Joint Pub 5-0, Doctrine for Planning Joint Operations, April 13, 1995, p. III-4.
- ⁴⁸ CJCSI 3010.02B, p. A-5.
- ⁴⁹ CJCSI 3170.01E, p. A-3.
- ⁵⁰ CJCSM 3170.01B, p. A-1.
- ⁵¹ CJCSI 3170.01E, p. A-4.
- ⁵² CJCSM 3170.01B, p. A-2.
- ⁵³ CJCSM 3170-01B, p. A-2; CJCSI 3170.01E, p. A-5.
- ⁵⁴ CJCSM 3170-01B, p. A-3; CJCSI 3170.01E, p. A-4.
- ⁵⁵ “White Paper on Conducting a Capabilities-Based Assessment (CBA) Under the Joint Capabilities Integration and Development System (JCIDS),” JCS J-8/Force Application Assessment Division, January 2006, p. 8.
- ⁵⁶ CJCSI 3170.01E, p. A-5.
- ⁵⁷ CJCSI 3010.02B, pp. B-5, B-6.
- ⁵⁸ Functional Concept for Battlespace Awareness, December 31, 2003.
- ⁵⁹ CJCSI 3010.02B, p. B-E-1.
- ⁶⁰ Quadrennial Defense Review Report, February 6, 2006, pp. 70-71.

⁶¹ The complete final report of the DAPA Project can be found at the web site

<http://www.acq.osd.mil/dapaproject/>.

⁶² QDR 2006 Report, p. 68.

⁶³ CJCSM 3170-01B, p. GL-16.

⁶⁴ The programs in the system of systems supporting a given joint capability area are regarded as core when their primary justification is their contribution to the capability area. The other system of systems programs, that have missions in support of other capability areas, are regarded as ancillary programs. The options in this paper are intended to provide some degree of centralized management authority over the acquisition of the core programs, as well as a systems engineering process to develop and control formal interfaces between all programs (core and ancillary) in the system of systems.



This page intentionally blank.

Chapter 5: A Potential Integrated Capabilities Development Planning Process Flow

This chapter presents one potential integrated process that reflects some of the key principles and process options outlined in Chapter 4. (All of the specific options presented in previous chapters, many of which are referenced in this chapter, are listed in Appendix I.) The process depicted here is not the only feasible path for implementing the principles presented in this report, nor does it provide an exhaustive list of every relevant process component, input, or output. Rather, it summarizes the potential interaction of the most important components, inputs, and outputs in an integrated capabilities development planning process.

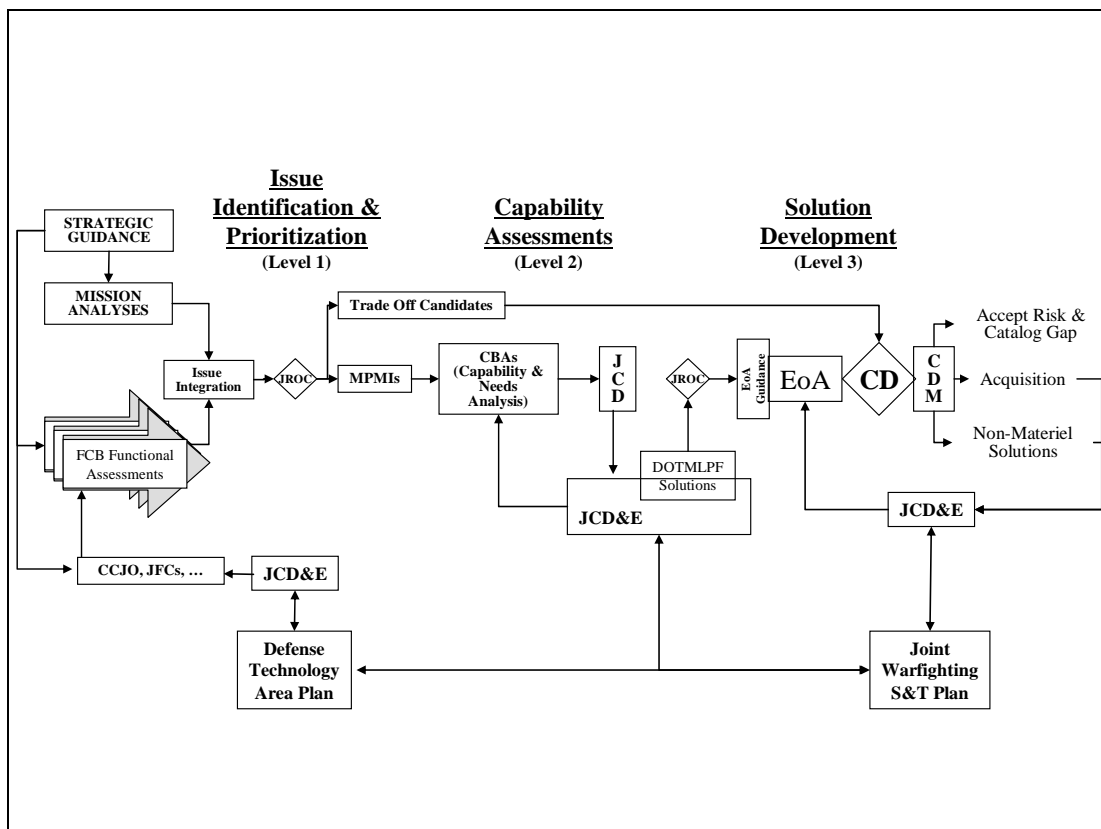

Figure 5.1: Summary of Potential Integrated Process Flow for Capabilities Development Planning

Figure 5.1 depicts this integrated capabilities development planning process from the articulation of strategy to the allocation of resources. The boldfaced headings at the top of the figure associate the process elements with the three levels of analysis and planning introduced in Chapter 4. These are the activities that together could constitute an ongoing, repeatable “battle-rhythm” for DoD planning and analytic staffs to support the key decision points outlined in previous chapters. The figures throughout the remainder of this chapter provide more detailed depictions of the process flow in Figure 5.1.

The steps associated with level-1 “Issue Identification & Prioritization” are shown in Figure 5.2. Analytic outputs from throughout the Department provide the key inputs for issue prioritization, and are shown in Figure 5.2 in a few different forms: COCOM and CSA “Mission Analyses,” Services’ “Force Development Analyses,” and “FCB Functional Assessments.” The first two of these describe activities that already exist in the Department. The last, however, “FCB Functional Assessments,” does not currently exist as envisioned here, and merits further explanation.

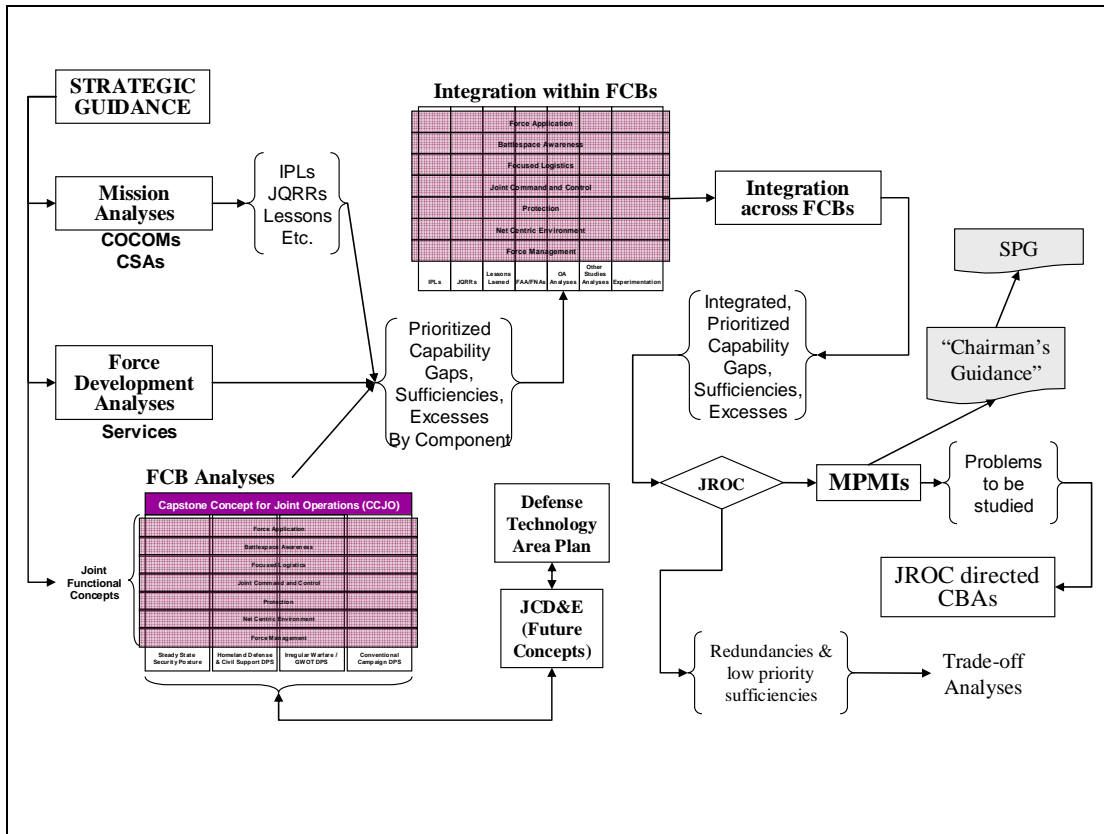

Figure 5.2: Detailed Potential Process Flow (Level 1 – Issue Identification & Prioritization)

The FCB Functional Assessments shown in Figure 5.2 are the instantiation of Option 4-A, which proposes the creation of regular JFC-wide gap and excess analyses by each of the FCBs. To reiterate the rationale for this process, the FCBs have a unique charter to assess all capabilities within the functional areas assigned to them by the JROC, across the full range of military operations. Establishing a regular assessment process, then, would simply implement that existing charter more fully and fulfill the guidance in CJCSI 3170 regarding the role of the FCBs in conducting holistic analysis.

The icon for this activity is shown in more detail in Figure 5.3. Matrices such as this one, showing the interaction of functional capability views with mission views, are a mainstay of defense analytic frameworks. Other prominent examples can be found in the Joint Warfighting Capabilities Assessment (JWCA) process of the Joint Staff's previous requirements generation system and the recommendations of the 2004 Aldridge Study. Any number of representations of functional and mission views is feasible, but one of the

key points of Figure 5.3 is that the Department already has well-established frameworks in place for representing these views. The JFCs and their associated FCBs provide the functional views, and the DPS and MSFD products of the Analytic Agenda provide detailed representation of missions for the future force. Moreover, the force planning construct established by the 2006 QDR and SPG, and soon to be further specified by the SSSP DPS, provide more detailed guidance on how future mission sets should be prioritized and combined for the purposes of force planning.

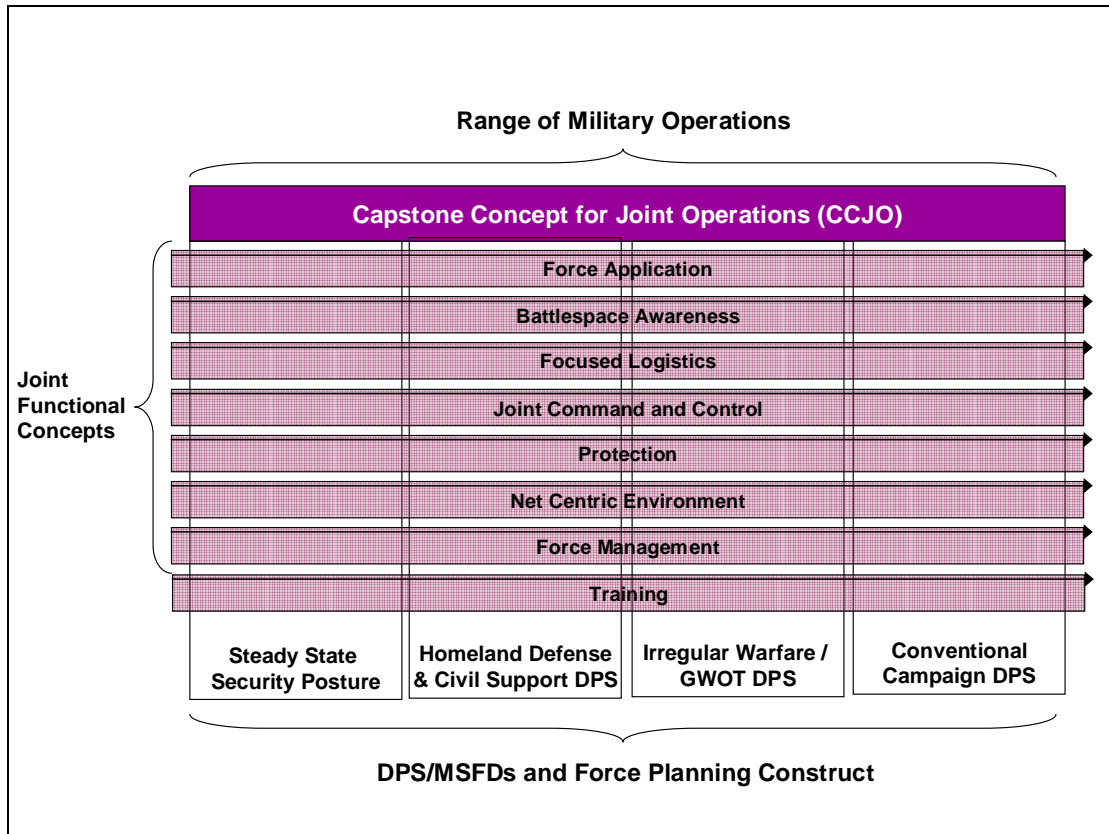

Figure 5.3: Level-1 FCB Functional Assessment

Not shown explicitly in Figures 5.2 or 5.3 are major joint strategic analyses such as the OA study series, though these should also be important inputs to joint issue prioritization. OA'05 and OA'06 studies, for example, took significant strides forward in attempting to integrate multiple DPS/MSFD products and align them with extant force planning constructs in the manner suggested here. Options 4-B, 4-C and 4-D address considerations regarding these studies, their potential overlap with the FCB Functional Assessment shown here, and issues related to OSD/Joint Staff division of labor.

A final point with regard to Figure 5.3 concerns the role of joint concepts. Figure 5.2 shows "JCD&E (Future Concepts)" providing input to the FCB Functional Assessments. One of these inputs would clearly be the Capstone Concept for Joint Operations (CCJO), which, as suggested in Figure 5.3, sets the broad context for analyzing how the future force will prosecute future missions. The JFCs serve to define the boundaries and key tasks associated with each functional area. Another potential concept

input here would be the Joint Operating Concepts (JOCs). However, as noted in Chapter 4, JOCs developed to date have been very broad and general, and therefore difficult to incorporate as bases for mission analyses. The assumption made here is that if JOCs have any significant role to play, that would be primarily in informing the development of CONOPS within the DPSs and MSFDs. Option 4-W provides some further discussion of the role for JOCs. Also, the interaction shown in Figure 5.2 between future concepts and the DTAP reflects the discussions relating to Option 4-Y, which suggests the need for greater interaction between concept developers and the S&T community.

The output of all of these level-1 analyses produces the “Prioritized Capability Gaps, Sufficiencies, Excesses By Component” shown in Figure 5.2. The next step is to integrate these various inputs, a process that is shown here in two sub-steps: integration within FCBs, and integration across FCBs. The first of these is shown in more detail in Figure 5.4. The basic framework for integration within FCBs is the same as that for the FCB Functional Assessments, but the set of mission views incorporated in the vertical axes now spans multiple time frames and includes a more diverse variety of sources for inputs on issue prioritization. In this step, the FCBs would continue to be responsible for prioritizing within their assigned functional areas.

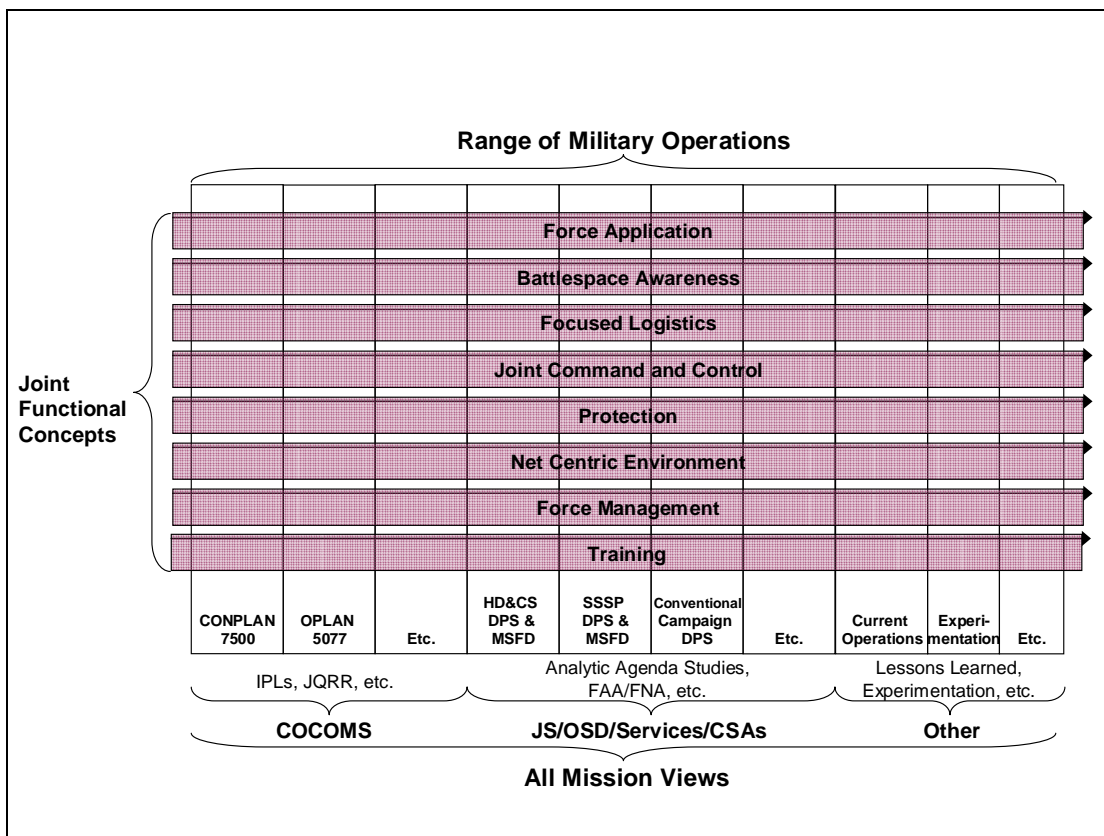

Figure 5.4: Level-1 FCB Issue Integration

The second sub-step requires a prioritization of issues across the FCBs, and therefore must be managed at a level above the FCBs. All of the preceding analyses to this point should provide Joint Capabilities Board (JCB) or JROC-level decision-makers ample

basis for making these choices, at least to the extent that the choices will be made on analytical grounds. In the final steps shown in Figure 5.2, the JROC decision point following cross-FCB integration would result in a list of the Chairman's prioritized issues (MPMI) as well as some identified "redundancies & low priority sufficiencies." The MPMI provide a basis for both the Chairman's input to the Secretary on strategic guidance and the prioritization of more detailed joint analytic attention in level-2 and level-3 activities; that is, it focuses efforts on the key "problems to be studied."

The "redundancies and low priority sufficiencies" are also critical outputs of the various level-1 analyses and issue prioritization process. When resource allocation decisions are made in the budget cycle, new investments must be paid for somehow. Given the realities of politics and organizational behavior, identifying and deciding on resource trade-offs will never be easy or straightforward. But this only enhances the impetus for making the process for doing so as rigorous and transparent as possible. This need is addressed in Option 4-L. While the budget cycle demands a regular (annual or biennial) integration of trade-off decisions, it is important to note that insights about low-priority capabilities and potential trades may emerge at any level or point in the capabilities development planning processes.

The main elements of level-2 "capability assessments" are shown in Figure 5.5. The centerpiece of these activities would be JROC-directed analyses that are analogous to the FAA and FNA steps of Capability Based Assessments (CBAs). As noted in Option 4-G, the terminology of FAA and FNA is misleading as currently used, since what is typically analyzed in a CBA is a mission area such as Undersea Warfare or Forcible Entry rather than a functional area. Figure 5.5 replaces the terms FAA and FNA with "Capability Issue Analysis" and "Capability Needs Analysis," respectively.

The goal of these analyses would be to greatly refine the Department's understanding of the prioritized gaps identified by the various level-1 analyses. Capability Issue Analysis would define the conditions, standards, attributes, and prioritized tasks required for a given capability, and Capability Needs Analysis would compare programmed resources with those attributes to generate a specific capability gap. In terms of JCIDS, the output of these steps would be a JCD. In more general terms, the output would be a detailed definition of a high-priority "problem to be solved."

As noted, in principle, these steps do not differ significantly from the existing processes for conducting CBAs. However, the steps shown here do contain a few important elements that depart from current practice.

- First, initiation of CBAs is driven by capability issues identified by the JROC as high-priority issues, not by component priorities or programs in search of justification. It is critical to note here that component program priorities are not excluded from joint examination in this process. To the contrary, they represent some of the most important inputs to the process, but only at the level-3 solution development stage, not at the level-2 capability assessment stage. This will be addressed in more detail below.
- Second, the prioritized conditions, standards, etc. established by the Capability Issue Analysis should be based on analysis of specific, JROC-directed scenarios. These might be near-term plans and CONOPS or mid or long-range

scenarios from the Analytic Agenda. This issue is also addressed in Option 4-H.

- While some capability gaps may call for materiel solutions or changes in posture, others may call for the development of a new concept. This presents an opportunity to link concept development and experimentation efforts directly into the capabilities development planning process. This could provide a new role for JICs. As shown in Figure 5.5, the development and experimentation related to such concepts could feed both new gap mitigation approaches and refinements to the detailed Capability Needs Analyses.¹

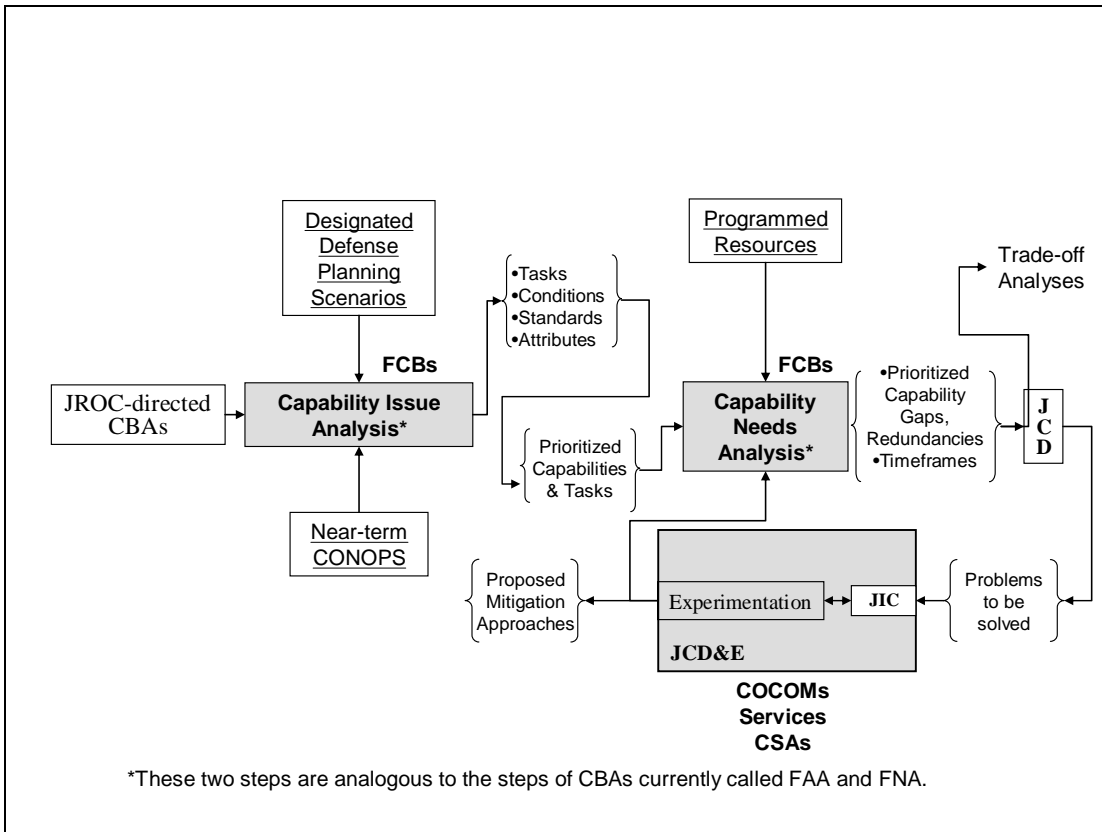

Figure 5.5: Detailed Potential Process Flow (Level 2 – Capability Assessment)

Capability excesses or redundancies, and lower priority capabilities that are sufficient and are identified in the capability assessment process provide additional detail to the priorities identified in level 1 for analyzing trades-offs.

Alternative DOTMLPF solutions and gap mitigation approaches constitute the main output of level-2 Capability Assessments and one of the main inputs for level-3 Solution Development. These process elements are shown in Figure 5.6. As depicted here, level 3 processes largely conform to the recently proposed process for Concept Decision, as shown in Figure 1.2 and discussed throughout this report. Generally, as suggested in Option 4-K, the time of the JROC and the Concept Decision review board continue to be focused by the prioritization mechanism in earlier steps. That said, a few additional elements shown here are worth highlighting.

The focus of level-2 activities on the Chairman’s identified MPMI (and other high-priority issues identified by the SecDef) does not exclude other issues and program initiatives from assessment in the capabilities development process presented here. Those initiatives enter the process at level-3 in the form of proposed solutions. And, clearly, the scope of issues requiring the attention of the JROC and the Concept Decision review board will include not only issues from MPMI, but also any ACAT I programs, below-threshold programs designated as of special DAB interest by the USD(AT&L), and other programs designated as JROC Interest.

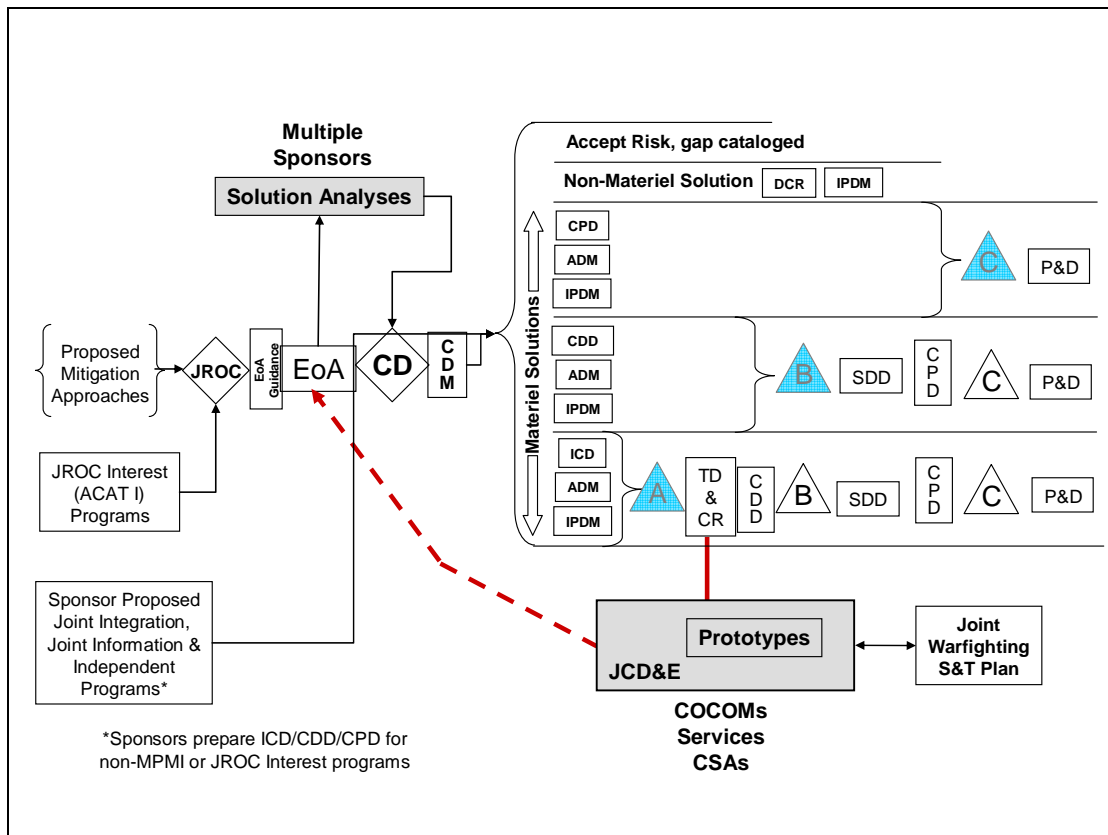

Figure 5.6: Detailed Potential Process Flow (Level 3 – Solutions Development)

This means that the Services would still submit ICDs (formerly mission needs statements, MNS) and CDDs (formerly operational requirements documents (ORDs)) as JCIDS proposals. These proposals would be based on Services’ own force development processes for identifying capability gaps and proposing programs.

All ACAT I program proposals, DAB interest items, and any other proposals not specifically addressing MPMI that the JCIDS Gatekeeper designates as JROC Interest would be submitted to the JROC as Concept Decision candidates. The number of proposals that the proposed Concept Decision process can handle in a given time interval has not been established. Whether it can accommodate all ACAT I programs and JROC interest proposals remains an open question.

In any case, proposals that are neither ACAT I, DAB interest, nor related to MPMI would be designated JROC Interest only by exception, based upon the Gatekeeper’s

judgment. This should reduce the number of JROC Interest JCDs, allowing JCIDS staffing to spend more time on level-1 analysis of priorities and staffing those priorities.

Another important feature of level-3 processes is that, to the extent possible, multiple sponsors would offer competing solutions for the “problems to be solved” identified by earlier steps. This is also addressed in Option 4-I.

Finally, Figure 5.6 shows another specific point where joint concept and development and experimentation can link directly into an integrated capabilities development planning process. In this case, JCD&E would serve as an important element of the concept refinement and technology development steps involved in acquisition Milestone A. This is also addressed in Option 4-J. And, just as future concepts like the CCJO and JFCs can benefit from enhanced interaction with the developers of the Joint Technology Area Plan, JCD&E activities at level 3 can benefit from enhanced interaction with the developers of the Joint Warfighting S&T Plan.

To summarize, the various process steps outlined here represent one integrated option for implementing many of the principles and options offered in this report. Undoubtedly, putting some of these steps into action would present challenges, on both analytic and organizational fronts. Chapter 6 addresses some of those potential challenges. At the same time, the integrated process offered here consists mostly of re-ordering or re-tasking of existing structures and activities rather than creation of new processes. This is by design. Whichever scheme is ultimately employed to improve the integration of capabilities development planning processes, it must be sensitive both to the need for better support to decision makers and to the feasibility of the organizational change that it demands.

End Notes

¹ Indeed, Figure 5.5 depicts a process that was used as part of the Joint Undersea Superiority CBA. Blue and Gold teams generated different concepts for achieving undersea superiority, then a variety of gaming, constructive simulation, and fleet exercises were used to refine the concept for a JIC.

Chapter 6: Conclusion – The Road Ahead

In recent years, DoD has taken many positive steps toward implementing the vision of rational, agile, joint planning that has been advanced under the banner of “capabilities-based planning.” In spite of this progress, however, considerable work remains to be done to improve the integration of the Department’s planning processes.

This report has attempted to identify the most important challenges in integrating those planning processes that are focused on defining, designing, and developing capabilities for the future joint force. It has also presented a variety of options for addressing those challenges. The general themes reflected in these options can be summarized as follows:

- Decision support processes should be designed and scheduled to inform the development of strategic guidance, not only react to it. In particular, the Chairman would greatly benefit from a more formal mechanism for generating and delivering integrated advice to the Secretary on the Strategic Planning Guidance document.
- A formal mechanism within the regular budget cycle for consideration of major capability trade-offs is an absolute necessity to rationally link strategic guidance to programmatic guidance.
- Greater joint analytic and management attention should be given to holistic, strategic-level assessments of the entire force against the entire set of missions required of the force; FCBs and COCOMs are natural candidates for conducting such assessments.
- These holistic assessments should be used to inform an issue prioritization process that would identify DoD’s highest-priority issues for further analytic and management attention.
- Detailed joint analysis and decision-making on capability needs and solution alternatives (such as JCIDS CBAs and the new Concept Decision reviews) should be focused on the identified highest-priority issues.
- JCD&E efforts should be balanced across future strategic-level discovery and concept development, support for capability gap analysis, and support for solutions development by co-evolution of DOTMLPF.
- Interaction between JCD&E and S&T communities should be enhanced.
- The quality of solutions to capability gaps would benefit from more competition among multiple sponsors and multiple alternative solutions.
- In order to speed the delivery of capabilities to the joint warfighter, schedule risk should be given greater weight in program decisions (“time-defined acquisition”).
- Assignment of programs to capability categories and “portfolios” should be tailored to specific needs and contexts.
- Definitions of near-, mid-, and far-term timeframes should be standardized across processes.

A guiding principle of this study was that significant improvements could be realized largely within the bounds of the main planning process already in place in DoD. These themes reflect that principle in that they generally do not require radical departures from existing organizational structures and authorities. Nevertheless, some of these themes point toward changes whose implementation would require some significant modifications in the way that existing organizations operate. Table 6.1 presents a brief overview of some of the potential implementation challenges associated with these themes.

Theme	Implied Changes	Challenges	Affected Organizations	Affected Guidance
Chairman’s guidance for SPG	<ul style="list-style-type: none"> Revival of JPD <i>AND/OR</i> <ul style="list-style-type: none"> Alignment of NMS, CRA, ARCCR 	<ul style="list-style-type: none"> May require modification of current statutory deadlines 	<ul style="list-style-type: none"> J-5 J-8 	<ul style="list-style-type: none"> CJCSI 3100 CJCSI 8510 Title 10 (if desired)
Trade-off analyses	<ul style="list-style-type: none"> New process 	<ul style="list-style-type: none"> Engaging senior leaders early in capability trade-off decisions Increasing or re-allocating analytic resources for supporting new process 	<ul style="list-style-type: none"> Joint Staff OSD (Policy) PA&E AT&L 	<ul style="list-style-type: none"> CJCSI 3137 CJCSI/M 3170 CJCSI 8510
FCB-directed level-1 analyses	<ul style="list-style-type: none"> Reprioritize or increase FCB workload 	<ul style="list-style-type: none"> Rules for agreeing on priorities Rules for accounting for capabilities (e.g. program element vs. unit type.) Aligning objectives with OA studies 	<ul style="list-style-type: none"> FCBs J-8 PA&E 	<ul style="list-style-type: none"> CJCSI/M 3170 CJCSI 3137
COCOM mission analyses	<ul style="list-style-type: none"> Holistic COCOM mission analyses (LPTR-like) 	<ul style="list-style-type: none"> Incentives for COCOMs to perform holistic analyses Agreeing upon methodology and data structure to support standardized inputs 	<ul style="list-style-type: none"> COCOMs J-8 J-5 OSD (Policy) 	<ul style="list-style-type: none"> CJCSI 8501 CJCSI 3113 CJCSI 3241 CJCSI 3500 CJCSM 3122 JP 5-0
Issue Prioritization (MPMI)	<ul style="list-style-type: none"> Change in FCB workload JCIDS/JROC focus on MPMI 	<ul style="list-style-type: none"> Methodology and tools to support prioritization process within and across FCBs 	<ul style="list-style-type: none"> FCBs J-8 JROC 	<ul style="list-style-type: none"> CJCSI 3137 CJCSI/M 3170

Table 6.1: Potential Implementation Challenges

Theme	Implied Changes	Challenges	Affected Organizations	Affected Guidance
Focus CBAs and Concept Decision on highest joint priorities	<ul style="list-style-type: none"> • JROC agendas • Fully implementing proposed Concept Decision process 	<ul style="list-style-type: none"> • Balancing focus with need to address competing issues and ACAT I/IA programs 	<ul style="list-style-type: none"> • FCBs • JROC • J-8 • PA&E • AT&L 	<ul style="list-style-type: none"> • CJCSI 3010 • CJCSI/M 3170 • CJCSI 3180 • CJCSM 3137
Balance JCD&E	<ul style="list-style-type: none"> • Balanced program among new concepts, problems to be solved and solutions • Improved linkage to JCIDS, Acquisition 	<ul style="list-style-type: none"> • Interpretation of role of Lead/ Executive Agent • Decentralized execution • Routine experimentation at COCOMs 	<ul style="list-style-type: none"> • JFCOM • J-7 • COCOMs 	<ul style="list-style-type: none"> • CJCSI 3010 • CJCSI/M 3170 • CJCSI 3180
S&T input into JCD&E	<ul style="list-style-type: none"> • Explicitly consider technological possibilities in developing concepts 	<ul style="list-style-type: none"> • Possible increase in responsibility / workload of S&T personnel 	<ul style="list-style-type: none"> • AT&L • J-7 • JFCOM 	<ul style="list-style-type: none"> • CJCSI 3010 • CJCSI 3180
Competing sponsor approaches to solutions analysis	<ul style="list-style-type: none"> • Implement Concept Decision process for MPMI 	<ul style="list-style-type: none"> • Integrating competing sponsor analyses 	<ul style="list-style-type: none"> • AT&L • PA&E • JROC • J-8 	<ul style="list-style-type: none"> • CJCSI/M 3170 • CJCSI 3180 • DoD 5000
Time-defined acquisition	<ul style="list-style-type: none"> • Implementing balanced JCD&E and evolutionary acquisition 	<ul style="list-style-type: none"> • Maintaining funding for capability-based evolutionary acquisition programs 	<ul style="list-style-type: none"> • J-7 • AT&L • JFCOM/COCOMs 	<ul style="list-style-type: none"> • CJCSI 3010 • CJCSI 3180 • DoD 5000
Portfolios tailored to process needs	<ul style="list-style-type: none"> • Implementing portfolios on multiple levels 	<ul style="list-style-type: none"> • Methods for conducting multi-attribute trades • Mapping databases 	<ul style="list-style-type: none"> • JROC • J-8 • AT&L • PA&E 	<ul style="list-style-type: none"> • CJCSI 3137 • CJCSI 3170 • DoD 5000
Business rules for timeframes and force apportionment	<ul style="list-style-type: none"> • Standardize definitions of timeframes across processes • Define force apportionment assumptions for analytical purposes 	<ul style="list-style-type: none"> • Agreement on purposes and analytical constructs • Agreement on basis for planning and authorities over assigned forces 	<ul style="list-style-type: none"> • JROC • Joint Staff • PA&E • Policy • AT&L 	<ul style="list-style-type: none"> • CJCSI 3100 • CJCSI 3010 • CJCSI 3137 • CJCSI 3170 • CJCSI 3202 • CJCSI 8501 • GFMG • DoD 5000

Table 6.1 (cont'd): Potential Implementation Challenges

Next Steps for Capabilities-Based Planning

Given the implementation challenges listed above, it seems clear that many aspects of capabilities-based planning remain ripe for further research and analysis. Among these aspects, three related priorities stand out:

- Developing **analytic methods and tools** for ensuring feasibility and credibility of level-1 analyses
- Tailoring capability **taxonomies and supporting data** structures to decision support needs
- Creating a **common management framework** for linking Force Employment Planning and Capabilities Development Planning

Analytic Methods and Tools

Applying greater emphasis in joint analysis to the holistic assessments described here as level-1 analyses would entail significant change for the defense analytic community. First, this type of analysis deliberately trades some depth for breadth. Second, it requires consideration of a diverse set of phenomena whose measurements are not obviously comparable. The preponderance of existing methods and tools in the defense analytic community are oriented toward data-intensive modeling of complex but relatively narrow physical phenomena. Many of these tools retain their relevance, of course, but they are generally not well-suited to level-1-type applications.

The challenge, then, is to ensure that analysts are equipped with the methods and tools that allow level-1 analysis to be sufficiently broad, sufficiently quick, capable of accommodating variability, and yet rigorous enough to be useful for supporting decision making. Some may argue that rigor is incompatible with breadth and speed, and certainly there is a tension between these competing objectives. Nevertheless, the dangers of misplaced precision and only “looking under the lamppost” for strategic insights are at least as great as the dangers of misunderstanding important issues for want of great detail.

Promising efforts to strengthen this part of the defense analytic tool kit are underway,¹ and support for such efforts should be an important priority for future research agendas.

Taxonomies and Data

One of the central conceptual challenges in capabilities-based planning is creating a reliable template for relating DOTMLPF inputs to mission-oriented outputs or “effects.” Input-output relationships in military operations are highly complex, highly context-dependent, and most military resources (people, equipment, systems, etc.) are capable of multiple functions that create different kinds of effects. This complexity makes construction of stable capability taxonomies inherently difficult. At the heart of this challenge is yet another dilemma in capabilities-based planning: capability taxonomies must be adaptable enough to reflect all of the complexity and context-dependency noted above. But those taxonomies must also be stable enough to support a common data structure that enables organizations throughout the Department to conduct their own

analysis and manage their own programs in ways that are transparent and understandable to senior decision makers.

It remains to be seen whether a standardized capability taxonomy can serve all the needs of the myriad stakeholders in defense planning. More likely, different types of taxonomies will need to exist in order to tailor these categorization schemes to different types of decisions. For example, a functionally-based taxonomy such as the current Major Force Programs is probably necessary to group resources for budgeting purposes. On the other hand, a mission-oriented or effects-based taxonomy may be necessary to aggregate operational metrics into a strategic assessment framework.

Joint Capability Areas (JCAs) represent the current state of the art in DoD for capability taxonomy development. This study did not attempt to assess the JCAs or the various activities surrounding their development. It is important to note, nevertheless, that an important contribution of the JCAs to date is that they have focused the Department on the need to move toward a common capabilities language and a system of data structures that support that language.

Common Management Framework

Significant improvements in DoD planning can be realized with a focus only on the processes designed to build the future force. This has been the main emphasis of this report. Ultimately, however, an ideal framework for DoD management would guide not only those capabilities development processes, but also those focused on allocating and employing the current force. The long-term goal for such a framework should be for the processes that support Contingency Planning Guidance development, Adaptive Planning, Global Force Management, training, and readiness reporting (among others) to share a compatible set of mission and capability taxonomies, metrics, risk assessment methods and data systems with capabilities development planning processes.

Finally, in addition to these priorities for further research, near term efforts to implement any of the options presented in this report should be closely coordinated with other efforts in the Department that are seeking to improve various aspects of the same planning processes. Prominent among these are the Institutional Reform and Governance initiative launched by the 2006 QDR, ongoing work in the Joint Staff J-5 to revise the directive for the Joint Strategic Planning System, and the JCA development activities mentioned above. Unity of effort throughout the Department is not only a main objective of capabilities-based planning, it is also a necessary ingredient for its success.

End Notes

¹ See for example Michael Fischerkeller, “Linking Plans to Resources (LPTR) Process,” March 15, 2006. Briefing available at http://www.dtic.mil/futurejointwarfare/cap_areas.htm; Institute for Defense Analyses, “Summary of the Strategic Risk Assessment Methodology (RAM) developed for use in Department of Defense strategic planning,” unpublished working paper, March 31, 2006; Paul Dreyer and Paul Davis, A Portfolio Analysis Tool for Missile Defense (Santa Monica, CA: RAND, 2005); Richard Hillestad and Paul Davis, Resource Allocation for the new Defense Strategy: The DynaRank Decision-Support System (Santa Monica, CA: RAND, 1998), Thomas L. Allen, et al, Analysis-Domain Modeling and Simulation Master Plan, Draft Paper, Institute for Defense Analyses, August 2006; other references available at the site for the February 2006 MORS Workshop on Analysis for Non-Traditional Security Challenges, <http://www.mors.org/meetings/ants/pres.htm>

Appendix A: Planning, Programming, Budgeting, and Execution (PPBE)

Background & History

The President is required to submit a budget to the Congress not later than the first Monday in February for the upcoming fiscal year. The entire schedule of the PPBE system is focused on meeting that legal deadline. PPBE is the name for the two-track DoD resource allocation system that has operated in two different forms since 1961. The first form is the most famous. It was installed by Secretary of Defense Robert McNamara and was known as PPBS (Planning, Programming, and Budgeting System). It was a highly centralized system that was fundamentally changed in 1969 by Secretary of Defense Melvin Laird. This second system is essentially the modern PPBS, which consists of a program and a budget developed by the Military Departments and the Defense Agencies. The program and budget are evaluated by the Joint Staff and OSD for their relevance to strategy, policy, and guidance. Those evaluations lead to decisions that create a budget for submission to Congress not later than the first Monday in February. This appendix presents a brief overview of that process.

Introduction to Terminology & Timing

The budget is the financial language of Congress that specifies the purpose, time and amount for spending appropriated funds. It has a legal status that guides the execution of appropriated funds. The program is a special display of the budget in terms of military capabilities and support activities. It tries to help the overall Department make its financial decisions on the basis of military capabilities (e.g. strategic forces, general purpose forces, mobility forces, etc.) instead of on the Congressional budget categories (e.g. procurement, personnel, etc.). Each component's program submission is identified as a Program Objective Memorandum (POM). The POMs are associated with the Future Year Defense Program (FYDP) database constructed from OSD Program Elements (PEs). The budget submission is referred to as the Budget Estimate Submission (BES). It is built around Congressional budget categories. The POM and BES are now submitted to OSD at the same time and are referred to as the POM/BES. Since 2003, the Department has reemphasized a two-year cycle for POM/BES preparation. The first year produces a two-year budget and a six-year FYDP, although Congress makes appropriations only one year at a time. The goal of the biennial budget is to submit the second budget year to the Congress with minimal changes.

PPBE Phases

Planning Guidance

Law, strategy and policy constitute standing guidance for development of the POM/BES. This includes any specific language included by the Congress in the prior years' budget or QDR-established policy. A program or budget must comply with all these forms of guidance. When a POM/BES submission does not comply, it is subject to change during the program or budget review. The specific annual guidance for POM/BES

development is currently issued in three documents. The first and most general guidance is the Strategic Planning Guidance (SPG), which focuses on setting strategic priorities. The second, and more specific, is the Joint Programming Guidance (JPG). A third planning document is the Fiscal Guidance, which identifies the maximum dollars of Total Obligational Authority (TOA) that may be contained in the POM/BES submitted by each component.¹ The issuance of the last of these guidance documents can be seen as the end of the PPBE planning phase.

Preparing a POM/BES requires an extensive set of activities within the Military Departments and Defense Agencies. The components must receive timely guidance to shape their submissions. The budget calendar makes this difficult. Guidance is difficult to establish until the previous year's budget is submitted in January or early February. The publication goal for the SPG is December, but both SPGs issued to date have not appeared until March. Additionally, for guidance to be most effective, it should direct specific results that will be reflected in the data submitted by the components. Guidance that is developed without an ability to measure its impact is often wasted. Finally, in the second year of the budget cycle, the PPBE process may omit developing some or all of the specific guidance for that year. In that case, the prior year's guidance remains in effect.

POM / BES Preparation

The POM and the BES were largely separate submissions over much of the history of PPBS. In the Military Services this has generally led to preparation of a POM and a BES by separate organizations. The BES was typically prepared by the Comptroller staff within the Secretariats of the Military Departments. The POM was prepared by a staff element working for the Service Chief. Each component submits its POM using OSD PEs and the BES using Congressional budget categories. These sometimes cannot be related at their lowest level of detail. Each Service develops its submission using specialized internal data which is sometimes different than the POM/BES data. The combined POM/BES submission has blurred these organizational boundaries and improved data compatibility, but problems remain.

Program / Budget Review

When the POM/BES is submitted, usually around the beginning of August, separate program and budget reviews begin to evaluate the submissions. These evaluations are respectively conducted by OSD(PA&E) and OSD(Comptroller). The evaluations compare the submissions with all guidance (statute, strategy, policy, and annual guidance). If there are deviations, the specific issues are developed for detailed review. Alternative decisions are developed for final decisions by the Secretary or Deputy Secretary of Defense in the next phase. In addition, there may be selected evaluations in areas directed by senior leadership. These could include areas such as ship-building or depot maintenance. The specific schedules, organization, and process schedule are tailored from year to year according to administrative memorandums issued prior to POM/BES submission.

POM/BES Decisions (PDM / PBDs)

Two different decision documents are used to direct changes to the POM/BES. The first is the Program Decision Memorandum (PDM), which reflects the issues and

alternatives considered during the program review. The second is a series of Program Budget Decisions (PBDs), which reflect the results of the budget review. The PDM contains detailed instructions to specific components directing them to make specified changes to the POM/BES. The number of PDMs for a review cycle can vary. There may be one for each Service, or two broader memos issued at separate times during or after the program reviews. There are approximately 50-100 separate PBDs each year. These decisions receive a final round of coordination prior to the decision. For PBDs, this final round of coordination is very short: approximately 24-48 hours. Input to these final decisions is required to be timely in order to meet the schedule for budget submissions to the Congress.

End Notes

¹ The Fiscal Guidance also contains additional technical and administrative guidance for preparing the POM/BES. Guidance of this type describes information such as department-wide inflation rates, information content and format, and administrative schedules. Examples of this kind of guidance are budget call memorandums issued by Comptroller organizations and the Programming Data Requirements (PDR) memo issues by OSD(PA&E).



This page intentionally blank.

Appendix B. Strategic and Planning Guidance

Top-down direction drives capabilities-based planning (CBP). This report distinguishes between “strategic guidance” and “planning guidance” in part because some strategic guidance is of little practical value to planners, and in part to avoid confusion since the name “Strategic Planning Guidance” applies to one formal document issued by the Secretary of Defense as part of the PPBE process.

At the top of the top-down guidance channel are national strategy documents – dubbed “touchstone documents” in this report because in their present form as unclassified, public documents, they convey broad context that informs subordinate documents, but they do not provide sufficient detail to serve as a basis for choosing among alternative military capability options or for assessing the resources needed to execute those options. Below the “touchstone” level are two categories of strategic and planning guidance: the first, force employment planning guidance, establishes what military forces are expected to do and provides the basis for mission analysis to identify the capabilities needed to accomplish assigned missions and tasks. The second category, capabilities development planning guidance, establishes priorities and allocates resources to the development and acquisition of capabilities. This appendix addresses each of these levels and categories in turn.

Touchstone Strategy Documents

Touchstone documents are the National Security Strategy (NSS) signed by the President, the National Defense Strategy (NDS) signed by the Secretary of Defense, and the National Military Strategy (NMS) signed by the Chairman of the Joint Chiefs of Staff.

NSS. Congress requires the President to submit a comprehensive report setting forth the national security strategy of the United States and including a comprehensive description and discussion of (1) the worldwide interests, goals, and objectives that are vital to national security; (2) the foreign policy, worldwide commitments, and national defense capabilities necessary to deter aggression and implement the strategy; (3) the proposed short-term and long-term uses of the political, economic, military, and other elements of national power to protect or promote national interests and achieve national security goals and objectives; and (4) the adequacy of the capabilities of the United States to carry out the national security strategy, including an evaluation of the balance among the capabilities of all elements of national power. The first such report is due from a new administration 150 days after the President takes office; subsequent reports are due annually on the same date as the President’s budget for the next fiscal year. The law says each such NSS shall be transmitted in both classified and unclassified form, but all NSS documents since 1991 have been unclassified documents for public consumption rather than detailed guidance for planners.¹

NDS. Congress requires every four years a “quadrennial defense review” (QDR) to delineate a national defense strategy consistent with the most recent NSS prescribed by the President; to define a defense program and identify both the budget plan required to provide sufficient resources to execute the full range of missions called for in that strategy at a low-to-moderate level of risk and any additional resources (beyond those programmed

in the current future-years defense program (FYDP)) required to achieve a low-to-moderate level of risk.² QDRs conducted in 1997 and 2001 each produced a national defense strategy, published as part of the QDR report. For the most recent QDR, a stand-alone NDS document was produced in 2005, and the stated purpose of the QDR was to operationalize that strategy.³

NMS. The Chairman is directed by Congress to submit a report to the House and Senate Armed Services Committees by 15 February of every even-numbered year, delineating a national military strategy consistent with the most recent NSS prescribed by the President and the most recent QDR conducted by the Secretary of Defense. The report in even-numbered years is to be accompanied by an assessment of the strategic and military risks associated with executing the missions called for in the strategy. In odd-numbered years, the Chairman submits a separate risk assessment to the Secretary, who forwards it to Congress as part of the President's Budget submission.⁴

Force Employment Planning Guidance

Force employment planning guidance is important to CBP because missions assigned to existing forces are critical drivers of capability needs. A number of formal documents provide such guidance to combatant commanders and, through them, to subordinate joint force commanders. The President assigns broad, enduring missions to combatant commands in the Unified Command Plan (UCP). More detailed and specific missions are assigned in the Contingency Planning Guidance (CPG) and Security Cooperation Guidance (SCG). The CPG, signed by the Secretary and approved by the President, describes specific missions for which plans are to be developed. The CPG is augmented by Strategic Guidance Statements (SGSs), more detailed expressions of guidance developed by OSD (Policy) for approval and issuance by the Secretary. The SCG, which is written in OSD and signed and approved by the Secretary, provides the foundation for all DoD interactions with foreign governments and organizations.

The CPG and SCG guide development of the Joint Strategic Capabilities Plan (JSCP), the means by which the Chairman assigns planning tasks to the combatant commanders, directing them to prepare deliberate plans, in specified degrees of detail, for missions assigned by the UCP, CPG/SGSs, and SCG.

These documents, which together assign missions to joint force commanders, are described in detail below, together with the Global Force Management Guidance (GFMG), which prescribes the forces to be used in force employment planning, and determines which forces are actually available at the time of execution.

UCP. Congress requires the President, with the advice and assistance of the Chairman and through the Secretary, to “establish combatant commands to perform military missions.”⁵ To ensure these remain current, Congress requires the Chairman to review at least once every two years the “missions, responsibilities (including geographic boundaries), and force structure of each combatant command; and recommend to the President, through the Secretary, any changes to such missions, responsibilities, and force structures as may be necessary.”⁶ The UCP establishes combatant commands to accomplish broad geographic or functional (worldwide) missions.

The current (May 2006) UCP assigns the following general responsibilities to combatant commanders:

- Deterring attacks against the United States, its territories, possessions, and bases, and employing appropriate force should deterrence fail.
- Carrying out assigned missions and tasks and planning for and executing military operations, as directed, in support of strategic guidance.
- Assigning tasks to, and directing coordination among, the combatant command's subordinate commands to ensure unified action in the accomplishment of assigned missions.
- Maintaining the security of and carrying out force protection responsibilities for the command, including assigned or attached commands, forces, and assets.
- Certifying the readiness of assigned headquarters staffs designated to perform as joint task force (JTF) or functional component headquarters staff.
- Providing, as directed, trained and ready joint forces to another combatant command.
- Planning, conducting, and assessing security cooperation activities pursuant to strategic guidance. Functional combatant commanders will coordinate their activities to ensure that security cooperation activities support geographic combatant commanders' security cooperation strategies.⁷

The UCP defines the geographic areas of responsibility of regional combatant commands – Central Command, European Command, Northern Command, Pacific Command, and Southern Command – listing by name the countries for which each is responsible and delineating by latitude and longitude the ocean boundaries between them. It also describes in narrative form the specific functions assigned to the functional combatant commands: Joint Forces Command, Special Operations Command, Strategic Command, and Transportation Command.

CPG. DoD defines a contingency as “an emergency involving military forces caused by natural disasters, terrorists, subversives, or by required military operations.”⁸ A foreseeable contingency, such as defense of an ally from aggression or the evacuation of noncombatants from a threatened area, requires a contingency plan, defined as “a plan for major contingencies that can reasonably be anticipated in the principal geographic sub-areas of the command.”⁹

Congress requires the Secretary to provide the Chairman written policy guidance for the preparation and review of contingency plans. Such guidance – provided every two years or more frequently if needed – includes specific force levels and supporting resource levels projected to be available during the time such plans are to be effective.¹⁰

The CPG, prepared by OSD (Policy), is the vehicle by which the Secretary provides the congressionally mandated policy guidance to the Chairman (and combatant commanders) for preparing and reviewing contingency plans. CPG 2005 is a 60-page Top Secret document that provides guidelines, priorities, and assumptions for trans-regional and regional planning. It specifies key planning factors and other planning requirements;

identifies specific contingencies for which plans are to be developed; assigns to each plan one of four planning levels that specifies the minimum amount of detail required; prescribes which plans require the Secretary's approval; and establishes timelines for completing planning actions.

CPG 2005 establishes classified responsiveness goals and directs combatant commanders to identify impediments to those goals and the capabilities required to overcome them in their Integrated Priority Lists (IPLs), thus clearly linking capability needs identified during contingency planning to the resource allocation process.

CPG 2005 was approved by the President in September 2005 and is based on forces projected to be available as of 30 September 2006.

The CPG makes reference to Joint Operating Concepts (JOCs), calling them descriptions of how joint force commanders will operate against a range of potential adversaries' capabilities in the mid- and far-term. No mention is made of Defense Planning Scenarios. Also unmentioned in the CPG are Joint Capability Areas: forces remain the coin of the realm in contingency planning.¹¹

SCG. The SCG is the Secretary's guidance on the near-term use of resources for security cooperation, which the guidance defines as "the means by which the Department of Defense encourages and enables countries and organizations to work with us to achieve strategic objectives."¹² The SCG provides overall security cooperation themes along with guidance for a series of defined regions, which are different from the geographic areas of responsibility delineated in the UCP. For each region, the SCG provides objectives, partnerships, and key tools to be emphasized.

JSCP. Having mandated written policy guidance from the Secretary to the Chairman for the preparation and review of contingency plans, Congress assigned to the Chairman the function of providing for the preparation and review of contingency plans "which conform to policy guidance from the President and the Secretary of Defense."¹³ The Chairman meets this statutory requirement by publishing the JSCP.

The JSCP amplifies guidance from the SCG and CPG and assigns specific planning tasks to combatant commanders. In the past, the JSCP provided each combatant commander a list of forces, called apportioned forces, to assume would be available at the time of plan execution. Apportionments in the JSCP were based on military capabilities resulting from completed program and budget actions.¹⁴ Today, the apportionment tables that used to be part of the JSCP are published as part of another document, the GFMG, discussed below.

The JSCP is a Top Secret document, published as a single volume. Supplemental instructions provide more detailed planning guidance in selected functional areas.

The current JSCP is dated January 2005. It was actually published, in the absence of a new CPG, as Change 1 to JSCP 2002. JSCP 2006, based on the September 2005 CPG, is expected to be signed by the Chairman in early September 2006. Upon approval of JSCP 2006, a new CPG will be staffed in parallel with a new JSCP, with both targeted for publication in Fall 2007.

The force employment planning cycle is intended to begin with publication of a new CPG and JSCP every other year. The Adaptive Planning initiative being pursued by

OSD and the Joint Staff seeks to reduce plan development to six months or less in response to a new SGS, CPG, or allocation of forces. Once approved by the Secretary, the Chairman or the combatant commander concerned, deliberate plans remain “on the shelf” until cancelled or superseded. They provide a basis for execution if the contingency ever comes to pass.¹⁵

Global Force Management Guidance. Historically, forces have been assigned to combatant commands for purposes of training and to carry out peacetime mission activities, apportioned to combatant commands for purposes of deliberate planning, and allocated to a combatant command at the time of mission execution. The NDS published in March 2005 announced a departure from historic practices, as follows:

Our military needs to be managed in a way that will allow us to deploy a greater percentage of our force when and where it is needed, anywhere in the world. Thus, the Department is transitioning to a global force management process. This will allow us to *source* our force needs from a global, rather than regional, perspective and to surge capabilities when needed into crisis theaters from disparate locations worldwide. Our global presence will be managed dynamically, ensuring that our joint capabilities are employed to the greatest effect.

Under this concept, Combatant Commanders no longer “own” forces in their theaters. Forces are allocated to them as needed – sourced from anywhere in the world.¹⁶

To operationalize this part of the strategy, the Secretary issued Global Force Management Guidance in May 2005. The declared purpose was to integrate complementary assignment, apportionment, and allocation processes into a single process. Stated goals were to:

- Account for forces and capabilities committed to ongoing operations and constantly changing unit availability
- Identify the most appropriate and responsive force or capability that best meets the combatant command requirement
- Identify risk associated with sourcing recommendations
- Improve ability to win overlapping conflicts
- Improve responsiveness to unforeseen contingencies
- Provide predictability for rotational force requirements¹⁷

Determining Capability Needs Based on Force Employment Guidance

Determining capability needs starts with the mission, function, or task a particular force element is supposed to perform, under what conditions, to what standard. Joint doctrine describes one way in which missions are analyzed to identify the tasks that must be accomplished to achieve mission success. The Joint Training Master Plan (JTMP) describes another, and JCIDS directives describe a third. How these different mission analyses relate to one another is unclear, and the effect Global Force Management has on each is also unclear.

Joint Doctrine. Joint Pub 5-0, *Doctrine for Planning Joint Operations*, describes how the JSCP tasks combatant commanders to prepare joint operation plans using forces and

resources apportioned for deliberate planning. The phase of deliberate planning called “concept development” is accomplished by the supported commander responsible for developing the plan. The first step is mission analysis, in which the assigned task is analyzed, a mission statement is deduced, subordinate tasks are derived, and planning guidance is prepared and issued to the staff and subordinate and supporting commands.

The supported commander continuously identifies limiting factors and capabilities shortfalls as the plan is developed. Where possible, the commander resolves the shortfalls through planning adjustments and coordination with subordinate and supporting commanders. If shortfalls cannot be reconciled and the resources apportioned in the JSCP are inadequate to perform the assigned task, the supported commander reports these limiting factors and his assessment of the associated risk to the Chairman.

In the plan review phase of deliberate planning, unresolved shortfalls in force and resource capabilities are identified. Plans that contain critical shortfalls beyond the supported commander’s ability to resolve may be approved with the shortfalls identified; in such cases the supported commander is supposed to be provided with guidance regarding specific actions planned or programmed to redress the shortfalls.¹⁸

The current draft JSCP implies that combatant commands are not constrained to only their apportioned forces for purposes of contingency planning; instead, they can include forces apportioned to other “bins” as they develop their plans, provided they highlight their having done so during in-process reviews. How this more flexible system for force apportionment will affect the identification of shortfalls or excesses remains unclear.

The Chairman’s Instruction governing review of operation plans (OPLANs) does not explicitly address what to do about shortfalls identified by the supported commander, actions planned or programmed to redress them, or any cross-reference to the supported commander’s IPL. It does refer to an older set of published procedures that included a check by the Joint Staff J-8 to ensure shortfalls identified in plans were reflected on the combatant commander’s IPL, but the procedures were cancelled in May 2005 because the document had “served the purpose for which it was issued.”¹⁹ The current CPG puts the onus on combatant commanders to identify impediments and the capabilities required to overcome them in their IPLs.

Joint Training. CJCSI 3500.01C, *Joint Training Policy and Guidance for the Armed Forces of the United States*, describes how combatant commanders translate guidance into theater-specific strategies, missions, and plans. Through analysis of these missions and plans, each command develops a list of specified and implied tasks, which are translated into a common reference language using the Universal Joint Task List (UJTL) and called mission tasks. Further analysis by the COCOM commander and staff identifies the tasks that are, based on criteria established by the commander, essential to mission success. The UJTL tasks identified as mission essential are termed joint mission-essential tasks (JMETs). Required capabilities identified during mission analyses are based on the commander’s intent and joint doctrine, and are documented in the command’s JMET list, or JMETL. The JMETL identifies the command’s mission capability requirements and forms the basis for joint training requirements. The Defense Readiness Reporting System (DRRS) uses JMETLs as a vehicle for assessing the readiness of all DoD organizations at

all operational levels to conduct the missions they are assigned. These tasks should accurately reflect the capabilities required of all organizations.²⁰

Joint Capabilities Integration and Development System. The JCIDS operations manual describes a third way in which missions are analyzed to identify capability needs. (Also see Appendix D.) The first step in JCIDS analysis is a Functional Area Analysis (FAA), which identifies the operational tasks, conditions, and standards needed to achieve the desired outcomes for the military objectives. The FAA uses, as input, the national strategies, the Family of Joint Future Concepts, CONOPS, joint tasks, the capabilities list (e.g., the UJTL), and the anticipated range of broad capabilities that adversaries might employ and other sources. The output of the FAA is the list of capabilities and their associated tasks and attributes developed to the level required for analysis in the follow-on Functional Needs Analysis (FNA).

According to the Chairman's Manual, the FNA assesses the ability of current and programmed joint capabilities to accomplish the tasks, under the full range of operating conditions, to the designated standards, that the FAA identified. The FNA produces a list of capability gaps that require solutions, and indicates the timeframe in which those solutions are needed. This analysis describes the capability gap, overlap or problem in operational or broad effects-based terms and will include consideration of gaps or problems identified in combatant commander issues and IPLs.²¹

The two mission analyses conducted by combatant commanders – one to identify stated and implied tasks for deliberate planning and the other to derive mission-essential tasks for joint training purposes – both address current capabilities. Global Force Management presents a challenge in this regard. A combatant commander may know what forces he has apportioned for deliberate planning, but little reason to be confident those forces will be available for allocation at the time of OPLAN execution. Analyzing missions to determine shortfalls may be problematic if planners do not know what forces to expect at the time of execution.

Development of a Joint Training Plan may also be problematic under Global Force Management. Analyzing assigned missions to identify mission-essential tasks for the JMETL is no different, but determining which forces need to be trained to accomplish those tasks, and then making sure they are trained, is a questionable undertaking.

Title 10 says that a combatant commander is “directly responsible to the Secretary for the preparedness of the command to carry out missions assigned to the command.”²² However, the combatant commander may have little control over what forces he has to train or what forces will be allocated to him at the time of execution.

Capabilities Development Planning Guidance

While closely related to force employment planning, capabilities development planning is distinguished by its focus on design of the future joint force rather than the employment of the current joint force. Accordingly, capabilities development planning activities must address future missions, capabilities, and concepts in addition to current ones.

Capabilities Development Planning in the Cold War. The National Security Act of 1947 directed the Joint Chiefs of Staff “to prepare strategic plans and to provide for the strategic

direction of the military forces” – responsibilities later assigned exclusively to the Chairman. In mid-1952, a JCS directive called for a mid-range strategic plan as the first step in the Department’s budget cycle.

The mid-range strategic plans prepared by the JCS during the Cold War repeatedly ran into issues that prevented their having the intended influence. The most prominent recurring issues from Cold War strategic planning by the JCS are summarized below, drawn primarily from Walter S. Poole, The Evolution of the Joint Strategic Planning System, 1947-1989, Joint Chiefs of Staff Special Historical Study, Historical Division, Joint Secretariat, Joint Staff.

- Differing conceptions of war. In the 1950s, joint planning was frustrated by differing conceptions of war among the Services. Air Force planners envisioned a short war in which nuclear exchanges would prove decisive, fought by forces in being, with strategic air power dominating. Army, Navy, and Marine Corps planners projected instead a massive buildup over many months, similar to World War II. Disputes over the capabilities needed continued to plague the JCS, with their recommendations often reflecting “splits” rather than consensus.
- Unconstrained ends versus constrained means. Throughout the Cold War, the force levels recommended by the JCS typically cost more than the incumbent administration was willing to fund, while those that the Secretary or the Chairman favored frequently proved too low to meet the “pure” military requirements. Two distinct force recommendations emerged over time: the “required” or planning force and the “expected” or program force.
- Shifting planning horizons. As first conceived, the Joint Strategic Objectives Plan (JSOP) was to address requirements through the first four years of a general war assumed to begin on 1 July of the third year after the plan was approved. The planning horizon was adjusted several times thereafter, sometimes at JCS direction and sometimes to match OSD methodology. Mid-term planning was adjusted in 1989 to cover the same six-year period as the FYDP. Similar shifts affected long-range planning. In 1952, the Joint Long-Range Strategic Estimate (JLRSE) covered the five-year period beginning five years after its date of issue, forecasting probable areas of conflict, outlining the type of war expected, and describing the basic strategic concept. The JLRSE was replaced by the Joint Long Range Strategic Study (JLRSS), which reviewed the world situation 8-12 years in the future. The JLRSS was replaced by the Joint Long-Range Strategic Appraisal (JLRSA) to consolidate intelligence estimates, strategic forecasts, broad force structuring implications, and probable issues in a single document. The JLRSA was in turn replaced in 1989 by a long-range planning annex in the Joint Strategic Planning Document (JSPD), which was later replaced by the National Military Strategy Document (NMSD). In 1997, the NMSD was eliminated, and with it the long-range planning annex.
- Combatant commander versus Service “requirements.” For most of the Cold War, the Services dominated strategic planning. They, not the combatant commanders, determined what forces were needed to accomplish the strategic objectives of the mid-range plan. A 1985 Senate Armed Services Committee staff study found the

geographic separation of the combatant commanders made them dependent on the JCS to represent their views, and that the JCS were ineffective in doing so. Goldwater-Nichols legislation made the Chairman the spokesman for the combatant commanders on the operational requirements of their commands, and empowered them to participate directly in strategic planning and resource allocation.²³

- Disconnects in methodology. The force planning documents produced by the Chairman are related to and seek to influence the resource allocation processes of DoD, but the civilian leadership of OSD prescribes those processes, not the Chairman. Historically, JCS advice often lagged or proved incompatible with the planning phases and constructs preferred by the Secretary.
- Guidance overtaken by events. The complex interaction between force employment planning and the capabilities development planning of the PPBE process requires disciplined schedules and close coordination between large bureaucracies. Sudden upheavals in the strategic landscape, such as the start of a war or the end of one, tend to derail the bureaucratic processes and raise the level at which issues are explored and decisions are made, bypassing participants in the “normal” strategic planning process.
- Schedule compression. The Department’s intertwined processes feed the President’s Budget, which is due to Congress in February of each year. Each planning cycle is the subject of negotiation between OSD and the Joint Staff that results in an agreed schedule for the publication and review of major documents. Slippages at the front end of the process typically do not cause the whole schedule to slip; instead they cause already tight timelines to be compressed.

Capabilities Development Planning After Goldwater-Nichols. The Goldwater-Nichols Department of Defense Reorganization Act of 1986 made the Chairman responsible for strategic planning, in consultation with other JCS members and the combatant commanders. To keep pace with a rapidly changing strategic landscape, succeeding Chairmen repeatedly revised the Joint Strategic Planning System (JSPS) – the formal means by which, historically, the Chairman carried out the strategic planning and policy responsibilities assigned to him by law. This section addresses the changes from 1989 to 1999, the reasons behind them, and the extent to which they did or did not produce the desired outcome. This section is drawn primarily from Air Force Colonel Richard M. Meinhart, Chairmen Joint Chiefs of Staff’s Leadership Using the Joint Strategic Planning System in the 1990s: Recommendations for Strategic Leaders, Strategic Studies Institute, US Army War College, June 2003.

1989-1991: First post-Goldwater-Nichols revision to strategic planning instruction. In 1989 the Joint Strategic Planning Document’s (JSPD) Supporting Analysis was split into two separate documents. First, the “Planning Guidance” would set forth JCS positions on national military strategy and objectives, along with an Illustrative Planning Scenario to help develop mid-term force requirements. Then a “Planning Force” paper would describe the force levels needed to execute national military strategy with a “reasonable assurance of success.” The combatant commanders were now to participate at an early stage in developing the Planning Force document. They would supply their unconstrained

estimates of forces required to pursue national security objectives with a “virtual” assurance of success. These requirements would be presented in tabular form as the “CINCs’ Minimum Risk Force.”²⁴

The 1989 process also directed the Joint Staff to do an end-to-end evaluation of the products created by the JSPS and seek opportunities for further improvement. The result was a complete revision of the process in January 1990, which added front-end Chairman’s guidance and eliminated or combined many other documents. The strategic planning cycle was to begin with a Joint Strategy Review (JSR) for “gathering information, raising issues, and facilitating the integration of strategy, operational planning and program assessments.” The JSR would inform the Chairman’s Guidance document, which was to be published in alternating years to provide initial guidance for developing the National Military Strategy Document (NMSD). Two other formal documents – the JSCP and the Chairman’s Program Assessment (CPA) – followed later in the cycle.

This revision combined ten separate formal documents into the four identified above, all deliberately constrained in length. It required an assessment of the security environment, the JSR, to identify changes that directly affected the NMSD, rather than allowing other documents to be developed without first gaining consensus on the security environment. Most importantly, it was designed to make strategic planning responsive to the “top down” direction in the 6-10 page Chairman’s Guidance document.

The NMSD, which replaced the JSPD, was to provide the Chairman’s “recommended national military strategy and fiscally constrained force structure required to support the attainment of national security objectives during the defense planning period covered by the next Defense Planning Guidance.” This document, which CJCS General Colin Powell limited to 100 pages, included an NMS (which was to be formally approved by the President); recommended national military objectives; updated intelligence assessments; and provided military force options along with risk assessments. Annexes addressed intelligence; nuclear; command, control, and communications systems; research and development; mapping, charting and geodesy; manpower and personnel; and long-range planning guidance. This NMSD was intended to serve as the core in executing the Chairman’s strategic planning and direction responsibilities under Goldwater-Nichols.

The JSCP, now limited to 200 pages without annexes, continued to task the combatant commanders to develop global and regional contingency plans and apportioned forces to execute them. The JSCP served to fulfill the Chairman’s contingency planning responsibilities under Goldwater-Nichols.

Finally, the CPA, limited to 175 pages, was to reflect the Chairman’s review of Service POMs, assess the risks associated with the current force structure compared to the requirements of the combatant commanders, and offer alternatives.

Unfortunately, this strategic planning process was never implemented. Even this streamlined planning system – with carefully delineated responsibilities and somewhat rigid time schedules – could not keep up with the rapidly changing security environment. Rather than the formal JSR intended to result in Chairman’s Guidance, General Powell achieved a general consensus on the world environment at a 1990 combatant commanders conference. Then, after consulting with the other members of the JCS, he summarized this

consensus in a message that sufficed as formal Chairman's Guidance. General Powell also replaced the extensive classified NMSD with a short unclassified NMS in 1992.

1992-1995: Process revised to reflect the way things had been done since 1990. The most significant change, promulgated in 1993, was replacing the NMSD with an unclassified, generalized NMS. The Services, who had been left out of the process that produced the "Base Force" NMS in 1992, resisted the Joint Staff's efforts to do away with the formal system, insisting on regularly published strategic planning documents to ensure their influence over the process. The 1993 revision established a classified Joint Planning Document (JPD) to provide resource advice to the Secretary at the front end of the PPBS cycle; specified that the JSCP would be revised only when needed but reviewed at least biennially; and clarified that the Chairman's Guidance could be published through either a formal endorsement of the JSR or anytime the strategic environment so demanded.

1996-1997: Major changes incorporated. The next major process revision, begun in 1996, recognized several significant changes that had taken place, most importantly an expanded JROC and the newly established Joint Warfighting Capabilities Assessment (JWCA) process. It also formally introduced the new Chairman's Program Recommendation (CPR) document that had been added to influence more directly defense resource planning, in addition to the resource advice provided by the JPD and CPA. The aim was to fully synchronize these three resource documents – JPD, CPR, and CPA – and the expanded work of the JROC and the JWCA, which began in 1994, with the PPBS. As always, the JSCP was to task combatant commanders to prepare contingency plans, but a new requirement to submit theater engagement plans was added.

The 1997 revision retained the Chairman's Guidance, not as a separate document but as overarching strategic direction from the Chairman to the Joint Staff. It described a Joint Net Assessment process that integrated other work of the Joint Staff, Services, and combatant commanders, rather than producing a separate document. Finally, the Joint Vision document provided a conceptual template for future capabilities.

The JSPS was last revised in September 1999. The change expanded guidance on combatant commanders' theater engagement plans and further defined the relationship between the strategic planning system and the JROC and JWCA.

The Current Joint Strategic Planning System. CJCSI 3100.01A is dated September 1999, and the online version at the Joint Electronic Library says the directive is current as of 12 September 2003. But the Instruction has not been revised since long before the advent of capabilities-based planning. The directive says the JSPS forms the basis for interaction with DoD planning and budgeting systems by proposing military strategy, forces, and capabilities necessary to achieve national security objectives in a resource-limited environment. Key statutory responsibilities of the Chairman are discussed below in terms of how they are addressed in the 1999 JSPS directive.

Strategic Direction. The Goldwater-Nichols Act directed the Chairman to assist the President and the Secretary of Defense in providing strategic direction to the armed forces. As of 1999, the Chairman's mechanisms for providing advice regarding strategic direction were the Chairman's Guidance, Joint Vision Document, and NMS.

Chairman's Guidance. The Chairman's Guidance was intended to provide a common set of assumptions, priorities, intent, and critical planning factors required to develop strategies and plans. It could be promulgated as a separate document but could also be an integral part of the overall strategy development process.

Joint Vision. The Joint Vision document resulted from a recommendation made by the congressionally mandated Commission on Roles and Missions in 1995:

Operation DESERT STORM demonstrated that the military capabilities developed separately by each of the Services are individually superb. But they do not work well *together*. We believe this is because, in the absence of a unifying vision to guide their efforts, each Service develops capabilities and trains its forces according to its own vision of how its forces should contribute to joint warfighting.

We find a pressing need for a central vision to harmonize the Services' own views. In addition to the general aim of providing an overarching guide for developing joint warfighting requirements, a unified vision will . . . provide a framework for the development of common operational and organizational concepts . . . and a common base for assessments of current and future joint capabilities.²⁵

The first such Chairman's vision, Joint Vision 2010, appeared in 1996 and focused on the military capabilities needed 15 years into the future. This unclassified, 36-page document identified four broad operational concepts – Dominant Maneuver, Precision Engagement, Full-Dimensional Protection, and Focused Logistics – to provide a common direction for developing joint capabilities. A revision in 2000, Joint Vision 2020, kept the same four operational concepts but also emphasized joint command and control, decision superiority, and interagency operations.

National Military Strategy. At the Cold War's end, the formal document by which the Chairman advised the President and Secretary of Defense on the strategic direction of the Armed Forces was the classified National Military Strategy Document. CJCS Admiral William Crowe published the last NMSD in 1989, covering the period 1992 to 1997. Chapters addressed national military strategy, an appraisal of US defense policy, national military objectives, an intelligence appraisal, fiscally constrained force levels, net assessment options, and risk evaluation. Seven classified annexes covered functional subjects. The NMSD was accompanied by a shorter, classified NMS – essentially a summary of the NMSD. Both documents were forwarded to the Secretary for review, and the classified NMS was sent to the President for approval.

General Powell replaced the NMSD and classified NMS with a 27-page unclassified NMS that had no stated time period. The US military strategy of the Cold War, based on containing a global adversary and deterring global war, was replaced by one that focused primarily on deterring and fighting regional wars. Neither this NMS nor the two that followed (in 1995 and 1997) were formally sent to the President for approval.

Following the attacks of 11 September 2001 that began the Global War on Terrorism, the Chairman initiated a JSR to determine how strategy might have to change to deal with adversaries less susceptible to conventional deterrence. The resulting NMS 2004 was derived from the President's 2002 NSS and shaped by lessons learned in Operations ENDURING FREEDOM and IRAQI FREEDOM. The 2004 document was drafted in three parts – an unclassified main body that followed in the tradition of Generals Powell and

Shalikashvili and two classified annexes: the 2004 Chairman's assessment of risk to the NMS, and regional assessments. The unclassified NMS document was released to the public in March 2005, concurrent with the release of the stand-alone NDS.

Strategic Planning and Contingency Planning and Preparedness. Title 10 assigns to the Chairman two distinct functions regarding planning:

- Section 153(a)(2) charges him with “preparing strategic plans, including plans which conform with resource levels projected by the Secretary of Defense to be available for the period of time for which the plans are to be effective.”
- Section 153(a)(3) makes him responsible for “providing for the preparation and review of contingency plans which conform to policy guidance from the President and the Secretary of Defense.”

The law explicitly calls not just for “planning,” but for the actual preparation of plans. The Joint Strategic Objectives Plan first prepared by the JCS in the 1950s was such a plan, separate and distinct from the JSCP – the short-range plan intended to guide the disposition, employment, and support of existing forces.²⁶ The JSCP today continues to provide guidance to the combatant commands, Service Chiefs, and Defense agencies to accomplish tasks and missions based on near-term military capabilities, and implements deliberate planning guidance reflected in the CPG.²⁷

The 1999 JSPS instruction conflates the two distinct Title 10 planning functions into one. It discusses the JSCP under the heading “Strategic Plans,” implicitly declaring either the JSCP itself, or the plans produced in response to it, or both, to be strategic plans.²⁸ But a 1995 Army Strategic Studies Institute report by Douglas C. Lovelace and Thomas-Durell Young found that eliminating the NMSD and abandoning the Base Case Global Family of Operation Plans, which in their view had collectively served as a strategic plan, left the Chairman without such a plan, and that nothing had taken its place.²⁹

Lovelace and Young argued that the JSCP failed to satisfy the Title 10 description of a strategic plan, namely “a plan that specifies, in military terms, the national strategic objectives for the FYDP period and describes a strategy that rationalizes the resources expected to be available during the FYDP with the strategic objectives described in the plan.”³⁰ They found the JSCP to be structured primarily to cause combatant commanders to prepare contingency plans and that the JSCP did not meet the statutory requirement for a strategic plan. Lovelace and Young recommended that the Chairman develop a National Military Strategic Plan as his military advice to the President and the Secretary (and as the basis for other documents in the JSPS).³¹

In recent months, the Department of Defense published a “National Military Strategic Plan for the War on Terrorism” and other national military strategic plans are in the works, such as one on cyber assurance. These plans are focused on narrow mission sets, and while collectively they might some day add up to a plan of the type Lovelace and Young envisioned, individually they do not.

Programming Advice. Title 10 assigns the following specific functions to the Chairman under the general heading of providing advice on requirements, programs, and budgets:

- Advising the Secretary on the priorities of requirements identified by the combatant commands.
- Advising the Secretary on the extent to which the program recommendations and budget proposals of the military departments and other DoD components conform with the priorities established in strategic plans and the priorities established for the requirements of the combatant commands.
- Submitting to the Secretary alternative program recommendations and budget proposals, within projected resource levels and guidance provided by the Secretary, in order to achieve greater conformance with the priorities referred to above.
- Recommending to the Secretary a budget proposal for activities of each combatant command.
- Advising the Secretary on the extent to which the major programs and policies of the armed forces in the area of manpower conform with strategic plans.
- Assessing military requirements for defense acquisition programs.

The 1999 strategic planning instruction identifies the JPD, CPR, and CPA as the primary vehicles by which the Chairman would provide planning and programmatic advice to the Secretary.

The Joint Planning Document, which replaced the NMSD with all its annexes (including the long-range planning document) in 1993, was introduced to articulate the Chairman's strategy-based planning, broad programming direction, and priorities while taking into account the views of the Services and combatant commands. The JPD was to be the earliest formal planning and programming advice from the Chairman to the Secretary, intended to influence the drafting of the DPG.

The JPD initially comprised separate volumes: (1) Intelligence; (2) Nuclear; (3) Command, Control, Communications, and Computer Systems; (4) Mapping, Charting and Geodesy; (5) Manpower and Personnel; (6) Logistics; and (7) Future Capabilities. A lead Joint Staff directorate or Combat Support Agency developed each volume in coordination with the Services and combatant commanders; there was very little integration among the volumes. In 1997 the JPD went from seven separate volumes to one document with a cover letter and several chapters, representing comprehensive and coordinated advice on Chairman-approved topics.

The previously cited study by Colonel Richard M. Meinhart assessed the effectiveness of the JPD in influencing the DPG. Individuals who drafted the DPG told Meinhart they had not used the JPD as a guide, and the Joint Staff told him eliminating the JPD had been considered during the 1997 JSPS revision. The JPD did, however, have some less direct influence. Others who worked in the DoD resource arena reported to Meinhart that just producing the JPD had educated people who later made decisions on Defense and Service programs.³²

The JPD was to be submitted approximately six months before the scheduled publication of the DPG. Since 2000, however, the schedule has been altered, the DPG replaced by the SPG and JPG, and the JPD rendered moot. As a result, the Chairman currently has no formal mechanism to provide comprehensive, strategy-based

programmatic advice and to influence capabilities development, or to inform and guide the Joint Staff officers working those processes.

The Chairman's Program Recommendation was first submitted in 1995, but became a formal part of the JSPS only in 1997. Its goal was to influence the DPG by providing the Secretary with the Chairman's priority recommendations for the upcoming program. Today the DPG has been split into two documents, the SPG and JPG. The CPR is intended to influence only the JPG or early PDMs; as noted above, there is no formal document from the Chairman intended or timed to influence the SPG.³³

The Chairman's Program Assessment was introduced in 1990, replacing the Joint Program Assessment Memorandum that first appeared in 1978. Its purpose was, and is, to influence the program and budget review process by providing the Chairman's assessment of the POMs and recommendations for alternative funding. POMs as modified by PDMs are the baseline for the budget estimate submission. The CPA thus provides the Chairman a formal means to influence the Defense portion of the President's budget.

The CPA was conceived to be a biennial document of no more than 175 pages. As discussed earlier, however, the battle rhythm laid out in the 1990 JSPS never materialized. The formal JSR, intended to start the process and result in the Chairman's Guidance, was replaced by a combatant commanders' conference and a message from the Chairman summarizing the consensus achieved there. The voluminous classified NMSD and shorter classified NMS were replaced by General Powell's unclassified "Base Force" NMS. And the CPA, far from 175 pages, became a short, personal memorandum from the Chairman to the Secretary. In 1993 the JSPS was revised to make the CPA a one- or two-page memorandum, with enclosures to further explain the Chairman's views or identify program alternatives.

Goldwater-Nichols gave the Chairman authority to submit alternative program recommendations and budget proposals, but Chairmen prior to 1994 simply acknowledged or endorsed the Services' programs. While an elaborate process was created to produce a Chairman's assessment, Colonel Meinhart's review of that process found what it lacked was some sort of senior review body to meet and deliberate on contentious issues.³⁴ That gap was soon filled by the JROC.

Under Vice Chairman Admiral Bill Owens, the JROC in April 1994 went from validating military requirements and acquisition programs to providing programmatic advice on joint warfighting issues. Ten JWCA teams, each under a Joint Staff director, were established in 1994 to examine requirements and programs horizontally and jointly. With members from the Joint Staff, Services, OSD, combatant commands, and Defense agencies, the JWCA teams developed close links with other DoD resource processes and boards. In addition, the JROC made periodic "road trips" to visit the combatant commanders, brief them on current warfighting issues, and gain their perspectives and needed buy-in on proposed recommendations. The JWCA teams explored issues identified by the Chairman, combatant commands, and Services. Thus backed by rigorous analysis, the JROC members would gain face-to-face input from the combatant commanders, then deliberate among themselves and provide recommendations to the Chairman. The Chairman ultimately would decide what to include in his program recommendations and assessments.

With Admiral Owens as the driving force, the first CPA developed through this process in October 1994 challenged some programs submitted by the Services, called for about \$8 billion in additional funding over the entire Defense program, and recommended shifts in \$4 billion more. While affecting only a small percentage of the Defense budget, it served notice that the Chairman would no longer simply endorse Service programs.

With the advent of JCIDS, JWCA's were replaced by Functional Capability Boards (FCBs). FCB responsibilities include both JCIDS and non-JCIDS activities.

Strategic Assessments. The 1999 strategic planning instruction describes several assessments that were intended to support development of the Chairman's advice and assistance to the President and Secretary of Defense. These include assessments of:

- The ability of the NMS to achieve national security objectives.
- The ability of the strategic and theater plans to accomplish the NMS.
- The capabilities of the armed forces to accomplish the tasks and requirements of the strategic plans.
- The capabilities of US and allied forces in light of the capabilities of potential adversaries.

Assessment processes prescribed by the JSPS are the Joint Strategy Review and the Joint Net Assessment (JNA).

The Joint Strategy Review is described as a continuous process that periodically results in a product, sometimes a formal JSR report and sometimes other documents, such as a Joint Vision or NMS. For example, JSR 1997 resulted in a new NMS; JSR 1998 generated an annual report on the future security environment; and JSR 1999 was a more narrowly cast study of "asymmetric warfare" and its implications for military strategy. JSR 2000-2001 was used to help frame the "must address issues" the Chairman used as metrics for developing his assessment of QDR 2001 (published as Chapter VII of the QDR Report). In 2002, the Chairman directed a JSR focused on developing the new NMS – a process that continued through 2003 and 2004, and resulted in the new NMS 2004, signed by the Chairman and forwarded to the Secretary in May 2004 and released to the public in March 2005. JSR 2003 responded to OSD's new risk management framework, which manages elements of risk but has no up-front assessment process to lead it. CJCS General Hugh Shelton saw the need for such a risk assessment process and directed the J-5 to develop a methodology combining qualitative and quantitative analyses and able to produce risk mitigation and management options. The risk assessment process developed in JSR 2003 generated the annual risk assessment report to Congress that was appended to NMS 2004.³⁵

The Joint Net Assessment process is described in the 1999 CJCSI 3100.01 as the mechanism to assess force strengths and deficiencies in the context of the US ability to meet national security objectives. Strengths and deficiencies are assessed in terms of their effect on strategic plans. The instruction goes on to say that

The JNA process is a responsive system that collects and synthesizes data from ongoing assessment processes, war games, simulations, and studies to support strategy formulation and plan development. Current and future capabilities are

assessed based on projected and prioritized future national military objectives out to the end of the FYDP. The JNA process uses the concept of a risk evaluation force, which is a force structure built on CINC and Service recommendations and designed to have a reasonable assurance of success in accomplishing the full range of military operations that support NMS objectives.³⁶

The “risk evaluation force” described in this passage is similar to the “Required Force,” “Planning Force,” or “Minimum Risk Force” of earlier generations. However, in recent years such a force has not been built or used. The closest the Joint Staff came was in 2000-2001 when alternative force structures were built for analysis but never published.³⁷

JSPS-PPBS Interaction, circa 1999. Two Chairman’s instructions, both issued in 1999, describe the JSPS (CJCSI 3100.01A) and the Chairman’s, combatant commanders’, and Joint Staff’s participation in the PPBS (CJCSI 8501.01). Figure B.1 shows how the two processes were intended to work together to produce the FYDP – the official DoD program document. This simplified chart in effect describes the strategic planning battle rhythm as it was designed in 1999. The chart and the discussion that follows provide the baseline for understanding the changes that have come since 2000.

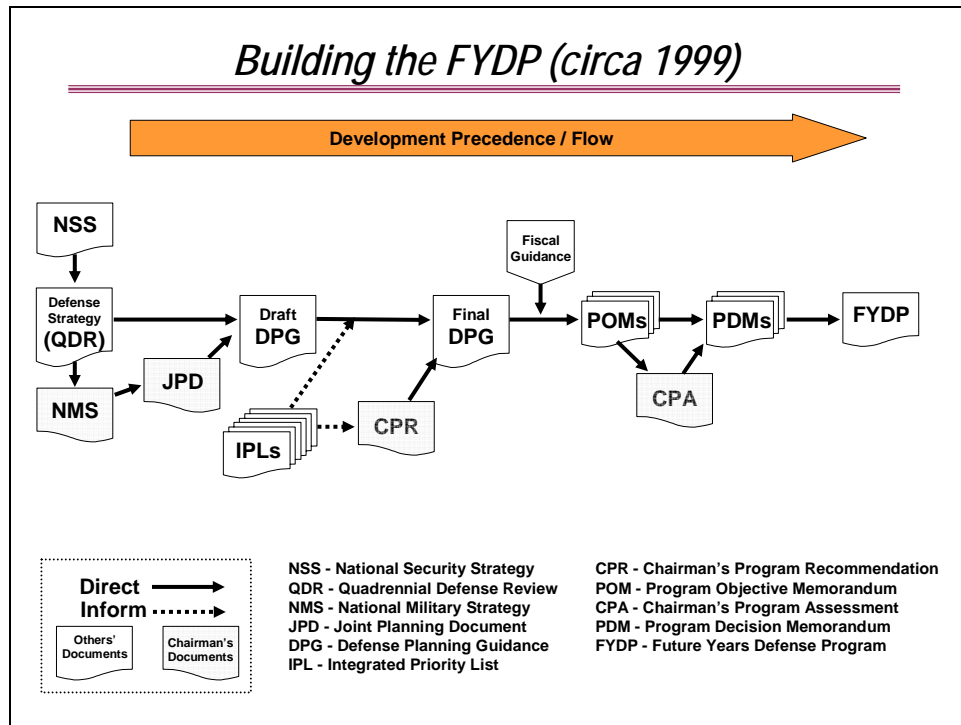

Figure B.1: Strategic Planning Documents Precedence and Flow (1999)

Under the 1999 directives, strategic planning to produce military capabilities began with the NSS, the President’s document under Title 10, Section 404a. An NSS report is due to Congress not later than 150 days after a new President takes office, or roughly 20 June of the year following a Presidential election. Subsequent reports are to be delivered to Congress together with the President’s Budget, not later than the first Monday in February of each year. The current NSS is dated March 2006.

The QDR is conducted during the year following a Presidential election year. Title 10, Section 118 requires that it delineate a national defense strategy consistent with the most recent NSS prescribed by the President, and define the defense program required to execute successfully the full range of missions called for in that national defense strategy. The first two QDR Reports were due to Congress by the end of the fiscal years in which they were conducted. The due-date was later changed to the first Monday in February of the year after the review is conducted, which made the report of the QDR conducted in 2005 due 6 February 2006.

When JSPS was last revised in 1999, there was no formal requirement for an NMS. CJCSI 3100.01A says only that the NMS serves as the Chairman's advice to the President and Secretary on how to employ the military in support of national security objectives, that it traditionally looks five to seven years in the future, that it is published as needed, and that historically it has been revised every three to five years. Congress since established in Title 10 a requirement for the Chairman to submit a report delineating the national military strategy in February of each even-numbered year.

The JPD is described in the 1999 instructions as representing the earliest formal, authoritative planning and broad programmatic advice from the Chairman to the Secretary. The JPD was to be submitted early enough in the annual cycle to influence development of the initial draft DPG.

The draft DPG was prepared by the Under Secretary of Defense for Program Analysis and Evaluation (PA&E) and was circulated for comment to the Chairman, the combatant commanders, the Service Chiefs, and the OSD staff.

The 1999 directives state that at a time and in a manner specified by OSD, the combatant commanders would each submit an Integrated Priority List, intended to identify priority needs across Service and functional lines and to identify suggested programs and cost estimates, within realistic fiscal constraints, needed to solve the problem areas. The J-8 would then analyze the IPLs to inform the Chairman about each combatant commander's most important concerns and common concerns shared across commands.

On or about 1 March, the CPR was to provide the Chairman's personal programming and budgeting recommendations, focused on enhancing joint readiness and warfighting requirements, to the Secretary.

The Secretary would consider the CPR in finalizing the programming guidance to be provided to the DoD components in the final DPG, usually published on or about 31 March.

The Deputy Secretary of Defense would issue Fiscal Guidance to components to specify their budget "top lines" as they prepared their program proposals.

The Military Departments, USSOCOM, the Defense agencies, and the Joint Staff would develop their proposed programs based on the guidance provided in the DPG and Fiscal Guidance. These programs, expressed in each component's POM, would reflect systematic analysis of missions and objectives, methods to accomplish them, and the allocation of resources (within each component's top line) to achieve them.

The CPA would provide the Chairman's personal assessment of the conformance of Service and agency POMs to the priorities established in the DPG and combatant

commander IPLs. The CPA was submitted to influence the final decisions of the Secretary on issues raised during the program review.

Following a staff review of the POMs, issues would be developed in detail and presented for discussion to the appropriate advisory body (in 1999, this was the Defense Resources Board, chaired by the Deputy Secretary of Defense, with Under Secretaries, selected Assistant Secretaries, the Secretaries of the Military Departments, and the Vice Chairman of the Joint Chiefs of Staff as members).

After all discussion had taken place, the Deputy Secretary would consult with the Secretary, and final decisions would be documented in a Program Decision Memorandum (PDM) to the DoD components. PDMs are authoritative documents that approve POMs as modified by decisions during the program review process.

The approved POMs would then be used to update the FYDP, the official document and database that summarize forces and resources associated with the programs approved by the Secretary. Though still subject to change as a result of decisions made above DoD level, for purposes of this study, the FYDP is the ultimate strategic planning document in the capabilities realm. If the forces and resources that together constitute a needed capability are not reflected in the FYDP, the capability does not exist, and will not exist until such time as they do make it into the FYDP, are developed, and fielded.

The JSPS-PPBS interaction of 1999 constituted a planning and programming battle rhythm based on a one-year cycle. OSD and the Joint Staff developed the actual timing of the output documents each year to ensure the CPR and CPA were completed in time to influence the DPG and PDM, respectively.

Developments Since 2000. President Bush arrived in office with a clear intention to transform the armed forces. In a September 1999 campaign speech at the Citadel in Charleston, South Carolina, then-Candidate Bush declared that

As President, I will begin an immediate, comprehensive review of our military – the structure of its forces, the state of its strategy, the priorities of its procurement – conducted by a leadership team under the Secretary of Defense. I will give the Secretary a broad mandate – to challenge the status quo and envision a new architecture of American defense for decades to come.³⁸

In that speech, President Bush said we would modernize some existing weapons and equipment, necessary for current tasks, but “our relative peace allows us to do this selectively.”

That “relative peace” was shattered on 11 September 2001, when terrorist attacked on the World Trade Center. The comprehensive review the President promised at the Citadel – the Quadrennial Defense Review 2001 – was nearing completion on 9/11, and when the report came out three weeks later it set in motion changes in several of the sub-process that together constitute CPB.

The QDR introduced a new Defense strategy and a new force-sizing construct; began a reorientation of the US military global posture; established a new Office of Force Transformation to evaluate the transformation efforts of the Services and recommend steps to integrate ongoing transformation activities; and outlined a new risk management framework intended to influence the way military forces are sized, shaped, postured, committed,

and managed. Last, and far from least, the QDR announced that DoD would explore options to fully redesign the way it plans, programs, and budgets. The Secretary's foreword to the QDR report declared that a central objective was to shift defense planning from the "threat-based" model of the past to a "capabilities-based" model for the future.³⁹

In response to the QDR direction to redesign the way the Department plans, programs, and budgets, the DPG directed a study of DoD decision-making processes that culminated in approval of Management Initiative Decision (MID) 913 in May 2003. MID-913 directed implementation of a two-year Planning, Programming, Budgeting, and Execution process to replace the PPBS that had served as the Department's central strategic planning, program development, and resource determination process since the 1960s. MID-913 declared that:

The Department's processes for strategic planning, identification of needs for military capabilities, systems development and acquisition, and program and budget development are not well integrated. The strategic planning process does not explicitly drive the identification of needs for military capabilities and acquisition processes. In addition, the program and budget development processes, while imposing fiscal discipline, often have failed to integrate strategic decisions into a coherent defense program.

A major goal of the Department is to strategically link any major decision – for acquisition, force structure, operational concepts, and infrastructure, for example – both to the DPG and to program and budget development.

The QDR will continue to serve as the Department's major statement of defense strategy and business policy. It will continue to be the single, hierarchical link throughout DoD that integrates and influences all internal decision processes.⁴⁰

The PPBE process of MID-913 retained as its central guidance document the DPG, with "on-year" and "off-year" variants. An off-year DPG would be issued at the discretion of the Secretary, and would not introduce major changes to the defense program, except as specifically directed by the Secretary or Deputy Secretary. However, MID-913 anticipated that a small number of programming changes would be required to reflect real-world challenges and the continuing need to align the defense program with defense strategy. A principal purpose of any off-year DPG would be to provide guidance on planning and analysis required to identify major program choices for the next on-year's planning guidance.⁴¹

MID-913 by itself did not necessarily require a major revision of the Chairman's strategic and planning guidance documents. As long as the DPG remained central, the JPD could continue to inform and influence the initial draft, the CPR could continue to influence the final DPG, and the CPA could continue to influence the Secretary's final decisions in the PDM. However, even while MID-913 was being developed, a major study was underway that resulted in the DPG's being replaced by two new OSD-prepared documents, each with a distinct purpose and each appearing to be amenable to well-timed input from the Chairman.

In March 2003, Secretary Rumsfeld chartered the Joint Defense Capabilities Study to examine how DoD develops, resources, and provides joint capabilities. The study was chaired by former Under Secretary of Defense for Acquisition, Technology, and Logistics Pete Aldridge; hence, it is widely known as the "Aldridge Study" and the process it

recommends as the “Aldridge Process.” The study team was tasked to examine and improve DoD processes for determining needs, creating solutions, making decisions, and providing capabilities to support joint warfighting needs. With regard to strategy, the study report found that:

- Defense strategy is not articulated in a concise form that provides integrated department-wide objectives, priorities, and roles as a framework for planning joint capabilities development. It is conveyed in numerous documents, many of which are outdated or contradictory.
- Much of the material in the current strategy documents originates in working groups and committees. This bottom-up process frequently results in a signature-ready document, but does not support early senior leadership involvement to shape strategic guidance up-front.⁴²

The study found that problems arising from this lack of a single, well-articulated defense strategy are exacerbated by guidance that is neither prioritized nor fiscally constrained. Because the Services receive guidance to do more than they can resource, they are forced to make their own tradeoffs to comply with fiscal constraints. Service needs routinely compete with joint needs, with tough choices required to create a fiscally responsible program. Service decisions made in their own best interests are then second-guessed by the combatant commands, the Joint Staff, and OSD, and often are overturned during program review. Consequently, the Services have little incentive to fund joint needs before program review.

The Aldridge Study argued that because combatant commanders are responsible for the accomplishment of missions, they are best suited to determine if the right capabilities are being delivered and should be the ones driving the strategy and feasibility assessments. Consequently, the Aldridge Study gives combatant commanders a larger role in shaping defense strategy. To enable combatant commanders to air their views on the near- and long-term challenges they face and shape the strategy to meet them, their staffs would need to shoulder increased responsibility for identifying and analyzing issues and coordinating with the Joint Staff.

The Aldridge Study recommended replacing the DPG with two new documents, the Strategic Planning Guidance (SPG) and Joint Programming Guidance (JPG).

The SPG would be a single, unified, fiscally-informed document that would:

- Establish strategic objectives and priorities
- Identify fiscal and other planning constraints
- Articulate priorities and risk tolerance
- Establish joint capability objectives
- Identify strategic concepts for planning future enterprise functions
- Identify future joint operational and organizing concepts

The intent of the SPG would be to begin the Department’s planning process by providing strategic direction rather than end the process, as the DPG had done, with specific programmatic guidance.⁴³

The second document replacing the DPG would be the JPG, envisioned as “a fiscally constrained business plan that addresses the totality of the defense budget.” The JPG would comply with the SPG, provide directive guidance on selected joint capability issues, and identify programmatic areas delegated to the DoD components.

Connecting the SPG and JPG would be a proposed Enhanced Planning Process (EPP) that would link strategy to program development by assessing current capabilities, analyzing gaps and excesses, and recommending alternatives for the Secretary’s decisions – decisions the Aldridge Study said would be captured in a “rolling capabilities plan” – not a published document but a repository of decisions made throughout the year and formally disseminated for action through the annual JPG. Thus while it might appear that the EPP is a short spasm of intense activity that takes place between the SPG and JPG, in fact the EPP was meant to represent a continuous, year-around process that is quite different from past practices. Where the previous system for deciding what capabilities would be produced featured periodic, discrete inputs from the Chairman to the Secretary (the CPR to influence the draft DPG and the CPA to influence the PDMs), the enhanced process proposed by the Aldridge Study would be one of continuous OSD-Joint Staff engagement.

Secretary Rumsfeld accepted the Aldridge Study’s process recommendations in October 2003, with a memorandum announcing the initiation of the Joint Capabilities Development Process. The memorandum established the following schedule:

1. In December the Secretary would issue a single, fiscally informed SPG, which would replace the policy/strategy sections of the DPG and might include some programmatic guidance on a few issues of paramount importance.
2. By Spring 2004, a collaborative, joint, enhanced planning process would formulate and assess major issues and present them for the Secretary’s decision.
3. In Spring 2004 the Secretary would issue fiscally constrained JPG that would record the decisions reached in the EPP phase. The JPG would replace the programmatic elements of the DPG and would include a demonstration that the programmatic guidance provided in the SPG and JPG is fiscally executable in its entirety.⁴⁴

Delays in implementation resulted in the first SPG being issued in March and the first JPG in June 2005.

Focus on the FYDP.

One of the chief objectives of Pentagon strategic planning is a coherent defense program that recognizes needs for military capabilities and develops and acquires solutions to those needs. Recognizing a capability need is only a first step in capabilities-based planning; getting a solution into the FYDP and fielded is the goal. Simply stated, if a program is not in the FYDP, it is not a “real” capability, or even on its way to becoming one. Many would argue that a program alone is not a capability, because it must be joined with doctrine, organization, training, etc. before a real capability can be said to exist. However, any of those elements of a capability that require resources must have those resources approved in the FYDP before they can be realized, so even non-materiel solutions leading to new capabilities cannot be considered real until the resources to enable them are provided in the FYDP.

Future Years Defense Program (FYDP)

- The FYDP officially summarizes resources associated, by fiscal year, with DoD programs, as approved by the Secretary or Deputy Secretary of Defense.
- The FYDP contains prior year (PY), current year (CY), two budget years (BY1 and BY2) through BY2 + 4 years (BY2 + 7 years for forces) [DoD 7045.7-H, FYDP Structure]
- By this definition, the FYDP for the FY 2008 budget year, due with the President's Budget by the first Monday in February 2007, would record resource totals for:
 - The Past Year, FY 2006
 - The Current (or Execution) Year, FY 2007
 - The Budget Years, FY 2008 and 2009
 - Four Years beyond the Budget Years, 2010 through 2013

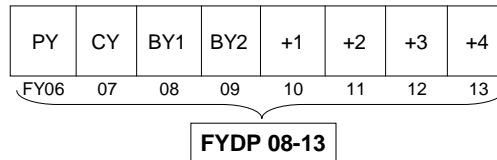

Figure B.2: Future Years Defense Program

The FYDP is the official document that summarizes forces and resources associated with the programs approved by the Secretary of Defense, covering an eight year period. Figure B.2 illustrates the FYDP associated with the FY 2008 budget, to be submitted to Congress with the President's Budget in early February 2007.

Figure B.1 described how the JSPS and PPBS interacted in 1999 to produce the FYDP on an annual basis. In addition to the switch from annual to biennial programming, other changes since 1999 have altered the sequence and flow of strategic planning. JCIDS changed the way needs are identified and solutions are developed. The Aldridge Study changed the way planning is conducted, in particular by changing the role of OSD from discrete, periodic inputs to continuous involvement in the EPP. Figure B.3 shows that while the processes are different in many respects, their overall intent is the same: to integrate strategic decisions into a coherent defense program, the FYDP.

Today as in 1999, Title 10 requires the Secretary, with advice and assistance of the Chairman, to provide written policy guidance for preparation and review of program and budget proposals. The guidance includes national security objectives and policies; the priorities of military missions; and the resource levels projected to be available.

In 1999 the DPG was issued in draft form early in the planning phase to provide broad strategic guidance, frame issues, and guide analysis. The DPG was issued in final form at the end of March to begin the programming phase. Fiscal Guidance was added separately, at the beginning of the programming phase.

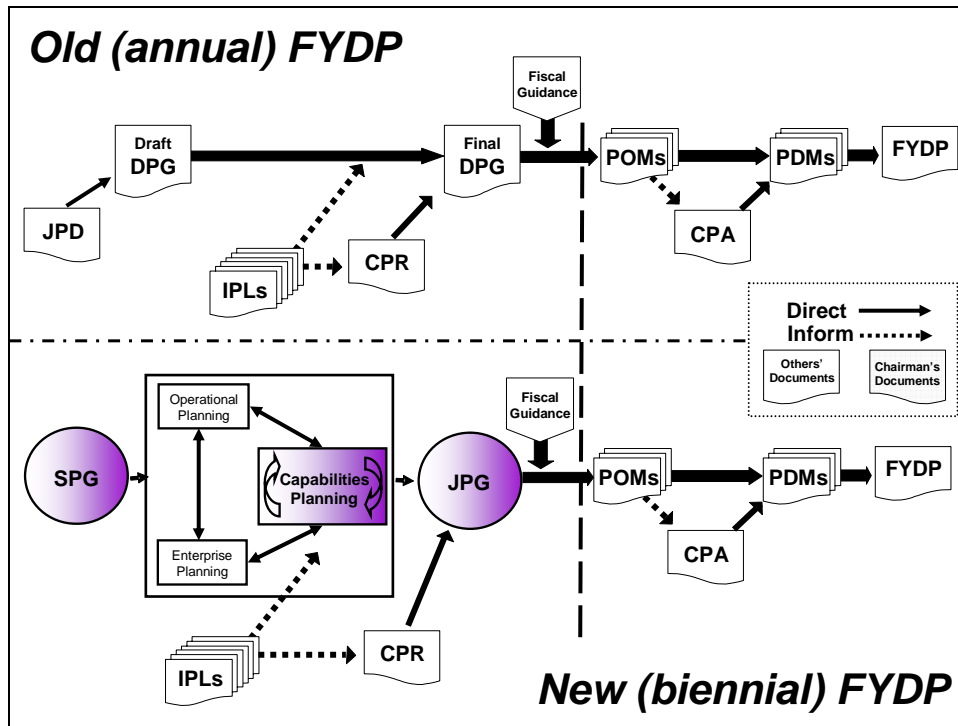

Figure B.3: FYDP Production, 1999 versus 2006

If a capability is not “real” until it is in the FYDP, then influencing the FYDP is the name of the game. Gaps identified in the near term can be solved in some cases by supplemental appropriations or shifting funds in the current year. Beyond the current year, gaps can be filled by taking money away from a program already in the FYDP – seldom an easy task – or by staking an early claim to the next two program years, for which guidance has not yet been issued. The decision points for those next two program years are the SPG and JPG, and those two guidance documents should drive DoD’s strategic battle rhythm, as shown in Figure B.4.

There are additional differences, but also similarities, in the 1999 interaction between JSPS and PPBS and the process that seems to be evolving:

- Combatant command IPLs are common to both 1999 and current processes, although what they are expected to cover has changed considerably and continues to evolve. Today the IPL is supposed to be a succinct statement of key capability gaps that could hinder the performance of assigned missions, prioritized by the combatant commander across Service and functional lines, and fiscally constrained.
- In 1999, the CPR was a formal document intended to influence the final DPG. Today, the CPR is submitted in parallel with preparation of the JPG and articulates the programs the Chairman deems critical for the Secretary to consider when identifying DoD priorities and performance goals in the JPG.

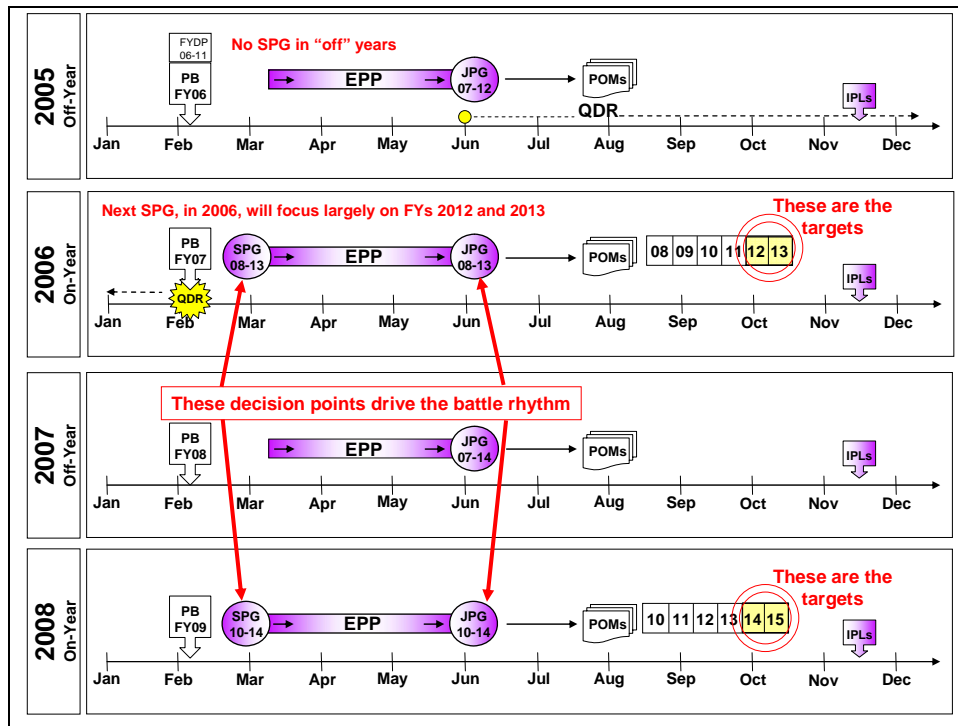

Figure B.4: The SPG and JPG Drive the FYDP, and the FYDP is the Target for the Acquisition of New Capabilities

- Today as in 1999, today the Military Departments, USSOCOM, OSD, the Joint Staff, and the Defense agencies develop their POMs based on the guidance provided (the DPG and Fiscal Guidance in 1999; the SPG, JPG, and Fiscal Guidance today). Each combatant command provides its warfighting requirements to its Service components or designated responsible commands for incorporation in the POMs.
- Today, as in 1999, the CPA is submitted to the Secretary after POMs are delivered to OSD. The CPA is designed to influence the program review process and the Secretary’s decisions, recorded in PDMs.⁴⁵

End Notes

¹ Title 50 United States Code, Section 404a.

² Title 10 United States Code, Section 118.

³ Guidance and Terms of Reference for the 2005 Quadrennial Defense Review (U), March 2005, p. 1.

⁴ Title 10 United States Code, Section 153(b) and (d).

⁵ Title 10 United States Code, Section 161(a).

⁶ Title 10 United States Code, Section 161(b).

⁷ Unified Command Plan, May 5, 2006, pp. 3-4.

⁸ Joint Pub 1-02, DoD Dictionary of Military and Associated Terms.

⁹ Joint Pub 1-02, DoD Dictionary of Military and Associated Terms.

¹⁰ Title 10 United States Code, Section 113(g)(2).

¹¹ Contingency Planning Guidance, 2005 (U)

¹² Security Cooperation Guidance, November 27, 2005, with Change 1 dated 1 June 2006.

-
- ¹³ Title 10 United States Code, Section 153(3).
- ¹⁴ CJCSI 3110.01E, Joint Strategic Capabilities Plan FY 2002(U), October 1, 2001.
- ¹⁵ Joint Pub 5-0, Doctrine for Planning Joint Operations, April 13, 1995, pp. 1-10 to 1-12.
- ¹⁶ The National Defense Strategy of the United States of America, March 2005, p. 20 (italics in original).
- ¹⁷ Global Force Management Guidance FY 2005 (U), May 4, 2005, p. I-1.
- ¹⁸ Joint Pub 5-0, pp. III-3 thru III-8.
- ¹⁹ Review of operation plans is now covered by CJCSI 3141.01B, Responsibilities for the Management and Review of Operations Plans, September 10, 2004. CJCSM 3141.01A, Procedures for the Review of Operation Plans, September 15, 1998, was cancelled by CJCS Notice 3141.01A, May 5, 2005, which said the procedures document had “served the purpose for which it was issued.”
- ²⁰ CJCSI 3500.01C, Joint Training Policy and Guidance for the Armed Forces of the United States, March 15, 2006, pp. B-1 to B-3. The Universal Joint Task List is maintained in the CJCSM 3500.04 series.
- ²¹ CJCSM 3170.01B, Operation of the Joint Capabilities Integration and Development System, May 11, 2005, pp. A-1 to A-3.
- ²² Ibid.
- ²³ Title 10 United States Code, section 155(c) and 163(b)(2); Vance Gordon, Dave McNicol and Bryan Jack, Revolution, Counter-Revolution, and Evolution: A Brief History of the PPBS, unpublished manuscript.
- ²⁴ Walter S. Poole, The Evolution of the Joint Strategic Planning System, 1947-1989, Joint Chiefs of Staff Special Historical Study, Historical Division, Joint Secretariat, Joint Staff, September 1989. p. 21
- ²⁵ Directions for Defense, Report of the Commission on Roles and Missions of the Armed Forces, 24 May 1995, pp. 2-2 and 2-3.
- ²⁶ Walter S. Poole, The Evolution of the Joint Strategic Planning System, 1947-1989, Joint Chiefs of Staff Special Historical Study, Historical Division, Joint Secretariat, Joint Staff, September 1989, p. 2.
- ²⁷ CJCSI 3110.01E.
- ²⁸ CJCSI 3100.01A, Joint Strategic Planning System, September 1, 1999, p. C-1.
- ²⁹ Douglas C. Lovelace, Jr. and Thomas-Durell Young, U.S. Department of Defense Strategic Planning: The Missing Nexus, Strategic Studies Institute, US Army War College, September 1, 1995, pp. iii and 13.
- ³⁰ Ibid., p. 4.
- ³¹ Ibid., pp. 16-17 and 31-32.
- ³² Colonel Richard M. Meinhart, Chairmen Joint Chiefs of Staff’s Leadership Using the Joint Strategic Planning System in the 1990s: Recommendations for Strategic Leaders, Strategic Studies Institute, US Army War College, June 2003, pp. 31-32.
- ³³ CJCSI 3137.01C, The Functional Capabilities Board Process, November 12, 2004, pp. D-1 - D-3.
- ³⁴ Meinhart, p. 33 and footnote 92.
- ³⁵ E-mail from Mark Haselton, former action officer in J-5 Strategy Division, October 29, 2004.
- ³⁶ CJCSI 3100.01A, p. E-5.
- ³⁷ E-mail from Mark Haselton, former action officer in J-5 Strategy Division, October 29, 2004.
- ³⁸ Public statement of Governor George W. Bush, given at the Citadel September 23, 1999, accessed October 16, 2004 at <http://www.vote-smart.org/>
- ³⁹ Quadrennial Defense Review Report, 30 September 2001.
- ⁴⁰ Management Initiative Decision 913, Implementation of a 2-Year Planning, Programming, Budgeting, and Execution Process, May 22, 2003, pp. 2, 4.
- ⁴¹ Ibid., p. 5.
- ⁴² The Honorable E.S. Aldridge, Jr., et al, Joint Defense Capabilities Study: Improving DoD Strategic Planning, Resourcing and Execution to Satisfy Joint Capabilities, Final Report, January 2004, p. 2-3.
- ⁴³ Ibid., pp. 2-9, 2-10.
- ⁴⁴ Memorandum from Secretary of Defense Donald Rumsfeld, “Initiation of a Joint Capabilities Development Process,” October 31, 2003.
- ⁴⁵ CJCSI 8501.01A, Chairman of the Joint Chiefs of Staff, Combatant Commanders, and Joint Staff Participation in the Planning, Programming, Budgeting, and Execution System, December 3, 2004, pp. B-3 and GL-2.

Appendix C. Analytic Agenda

Purpose of the Analytic Agenda¹

The Analytic Agenda is a set of activities designed to accomplish the following four objectives:

- Articulate, through scenarios, the Secretary's guidance to the Department about the missions, environments, and threats for which the future force should be prepared;
- Apply joint concepts to future missions depicted in planning scenarios;
- Produce standardized, accessible, transparent data and common assumptions for Department-wide use in analysis
- Design and conduct major joint analyses to support decisions on force structure, investments, and capability trade-offs.

At the time of this writing, OSD(Policy) has launched an effort to modify the process by which Defense Planning Scenarios and other Analytic Agenda products are produced. Since the nature and outcomes of those modifications have not fully emerged, this section focuses on the conduct of Analytic Agenda activities up to mid 2006.

Major Process Element Descriptions

Defense Planning Scenarios

The Defense Planning Scenarios (DPSs) are part of the Secretary's guidance to the Department on capabilities development planning and programming. Each DPS depicts a specific hypothetical operational challenge that might be faced by the future force. Together, all DPSs are meant to address a full range of major military operations.

DPSs are produced for two future timeframes, nominally the "mid-term" (FYDP +1) and the "long-range" (FYDP +11). In this way, the Analytic Agenda provides guidance and data for analyses supporting decisions that affect plans and programs that span both of these timeframes.

One DPS is unique and merits special description. The Steady State Security Posture (SSSP), formerly called the Baseline Security Posture (BSP), depicts overall global force posture rather than a single hypothetical challenge. In addition to projected overseas basing of forces, the SSSP depicts a number of representative lesser contingencies (e.g. humanitarian assistance, foreign internal defense, etc.) and ongoing operations (e.g. homeland defense surveillance, exercises, etc.). The purpose of the SSSP is to provide an estimate for the steady state demand on forces and to establish a starting point for the movement of forces in analyses of other scenarios.

The major steps of DPS development are as follows:

- Scenario selection
- Drafting of scenario framework, assumptions, variables
- Drafting of threat description and adversary CONOPS

- Drafting of Blue CONOPS
- Integration and coordination of complete scenario draft

OSD(Policy) is responsible for the overall design and production of DPSs, though other organizations play significant roles in their development, as described below.

*Scenario Selection.*² OSD(Policy) determines how many DPSs will be created, which scenarios will be created, and in which order they will be created. This determination is made based on a variety of factors, including the interest of senior leadership, coverage of a full range of military missions, and input from DoD components. In principle, the scenario set list and products are intended to be revalidated and/or updated at least every two years.³

*Drafting of Scenario Framework, Assumptions, Variables.*⁴ DPS development begins with the drafting of a basic scenario framework, including a narrative description of the “road-to-war,” statements of the major strategic and operational objectives of the major players, as well as descriptions of key assumptions and variables regarding such factors as warning time, allied support, and adversary use of WMD. OSD(Policy) leads this effort which could take anywhere from a few weeks to a few months to complete for a given scenario.

Drafting of Threat Description and Adversary CONOPS. See section below on data inputs to the Analytic Agenda.

Drafting of Blue CONOPS. See section below on Joint Concepts input to the Analytic Agenda.

Integration and Coordination of Complete Scenario Drafts. All scenario elements are combined, and then the draft document is circulated for two rounds of coordination to all relevant Components. Each round of coordination is followed by a comment resolution process and the final comment resolution process is followed by the publication of the final, approved DPS. OSD(Policy) leads this part of the process, which typically lasts approximately 3-4 months for a given scenario.

Multi-Service Force Deployment. Multi-Service Force Deployment (MSFD) documents are expanded versions of DPSs, and provide all of the scenario detail necessary for building databases for campaign-level analysis. MSFD development is conducted in close coordination with DPS development; the two processes are closely sequenced, development teams are shared, and OSD(Policy) oversees MSFD compliance with DPS guidance. MSFD content elements and process steps generally mirror DPS content elements and process steps described above, but at a greater level of detail. One crucial activity is unique to the MSFD development process: allocation of forces to scenarios. DPSs do not contain force allocations.

The Joint Staff J-8 leads development and production of the MSFD, which takes approximately six months for a single scenario. Usually, the first three months of MSFD development overlap with the second half of DPS development for the same scenario. The allocation of forces to MSFDs is also led by Joint Staff J-8, based on input from relevant Components and OSD.

Analytic Baselines. An analytic baseline is “a package comprising a scenario, concept of operations, and integrated data used by the DoD Components as a foundation for strategic

analyses. Examples of analytical baselines include scenarios and supporting data used for computer-assisted war games and theater campaign simulations.”⁵ Analytic baselines are generated in part by joint analyses, and also provide data for use in further analyses.

There are two varieties of analytic baselines: current year (CYAB); and future year (FYAB). CYABs are generated based on analysis of existing operational plans and current forces. FYABs are generated based on analysis of mid-term or long-range MSFDs and estimated programmed forces for those timeframes. The Joint Staff J-8 conducts or oversees production of CYABs,⁶ and OSD(PA&E) produces FYABs.⁷

Studies. In addition to the creation of scenarios and data to support analysis, the Analytic Agenda also serves as a venue for the design and conduct of selected joint analyses. The focus of these analyses is providing support to decisions on major joint issues, such as force structure, investments, and capability trade-offs.

The main Analytic Agenda study vehicle is the Operational Availability (OA) series, tasked by OSD(Policy) and conducted by the Joint Staff. These studies have also served to generate Future Year Analytic Baselines. Other major joint studies conducted under the auspices of the Analytic Agenda include the Mobility Capabilities Study (MCS) and the Joint Air Dominance Study (JAD). These studies may vary in duration from a few months to more than a year, though OA studies have been conducted annually since their inception in 2002.⁸

Oversight. The senior representatives with decision authority over Analytic Agenda management are PDUSD (Policy), D,PA&E, and D,J-8. Additionally, the Joint Analytic Data Management Steering Committee (JADMSC) is an advisory body that supports Analytic Agenda management and oversight.⁹ All Analytic Agenda products and data are controlled and disseminated by OSD(PA&E)’s Joint Data Support (JDS) office.¹⁰

Analytic Agenda Linkages With Other Planning Processes

Strategic Guidance – Analytic Agenda. Selection of content and assumptions for scenarios to be generated under the Analytic Agenda is guided by strategic and operational issues and priorities identified in official strategic planning documents, including the NSS, QDR, and NDS, but particularly the SPG. For current year analyses, the strategic guidance is derived from the CPG and associated Strategic Guidance Statements (SGSs). Scenario products and data produced under the Analytic Agenda should provide full coverage of all of the above issues and priorities.

OSD(Policy) is responsible for ensuring conformance of the Analytic Agenda scenario set with strategic guidance, and it shares responsibility with OSD(PA&E) and the Joint Staff J-8 in ensuring conformance of study design for joint analyses with priorities identified in strategic guidance.

Additionally, the results of joint analyses conducted under the Analytic Agenda should inform future rounds of strategic planning activities.

Joint Concepts – Analytic Agenda. The family of joint concepts (JOpsC), including the CCJO, JOCs, JICs, and JFCs, forms the basis for development of DPS and MSFD Blue CONOPS. Accordingly, the development processes for both DPSs and MSFDs feature a

standing working group for generating Blue CONOPS, chaired by the Joint Staff J-7 and composed of all relevant components and subject matter experts.

While joint concepts are meant to form the basis for development of DPS and MSFD Blue CONOPS, service concepts also inform that development. The venue for incorporating service concepts is the same as that for incorporating joint concepts: the CONOPS development working group for DPSs and MSFDs.

Data Inputs – Analytic Agenda. DoD Components support the development of Analytic Agenda products through provision of key data during the DPS, MSFD, and Analytic Baseline development processes. The Services, Combatant Commands, Joint Staff and JFCOM provide data on U.S. forces.¹¹ DIA represents the intelligence community in the process and provides intelligence projections and threat assessments for adversary capabilities and CONOPS.¹²

Planning and Programming Analysis - Analytic Agenda. Analytic Agenda scenarios and data are intended to provide the basis for analyses throughout the Department, especially in such venues as JCIDS CBAs. Component analyses conducted to support programming decisions are expected to use Analytic Agenda scenario and data products as a “starting point.”¹³

Also, the results of joint analyses conducted under the Analytic Agenda should inform future planning and priorities for concept development and experimentation. In particular, useful lessons for future concept development and experimentation may be derived from the application of joint concepts to CONOPS development for specific DPSs and MSFDs, the evaluations of those CONOPS conducted in studies, and alternative concepts developed throughout these processes.

Scenario products addressing the “long-term” future provide guidance to the Science and Technology planning community.

End Notes

¹ The most current official description on the purpose of the Analytic Agenda is: “Institute a comprehensive and systematic process to provide data for strategic analyses, using approved scenarios and ensuring that data are available, easily accessible, integrated, pedigreed, sufficiently detailed, and synchronized with Planning, Programming, and Budgeting System cycles.” (DoDD 8260.1, Data Collection, Development, and Management in Support of Strategic Analysis, December 6, 2002, 4.1)

² “The Under Secretary of Defense for Policy, in coordination with the Heads of the DoD Components, shall . . . Develop and establish priorities among scenarios for use by the DoD Components in conducting strategic analyses.” (DoDD 8260.1, 5.1, 5.1.1)

³ “The Under Secretary of Defense for Policy (USD(P)), in coordination with the Heads of the DoD Components, shall . . . Develop and/or update DoD scenarios for strategic analyses at least every 2 years.” (DoDI 8260.2, Implementation of Data Collection, Development, and Management in Support of Strategic Analyses, January 21, 2003, 5.2, 5.2.1)

⁴ “The Under Secretary of Defense for Policy, in coordination with the Heads of the DoD Components, shall . . . Issue scenario planning factors (e.g., warning time, concurrency, assumed postures of engagement) for use in strategic analyses.” (DoDD 8260.1, 5.1, 5.1.2)

⁵ (DoDD 8260.1, 3.1)

⁶ “The Chairman of the Joint Chiefs of Staff, in coordination with the Heads of the DoD Components, shall develop baselines for use in strategic analyses of current forces, based upon scenario priorities identified by the Under Secretary of Defense for Policy.” (DoDD 8260.1, 5.2)

⁷ “The Director of Program Analysis and Evaluation, in coordination with the Heads of the DoD Components, shall . . . Develop baselines for use in strategic analyses of future forces, based upon scenario priorities identified by the Under Secretary of Defense for Policy.” (DoDD 8260.1, 5.3, 5.3.1)

⁸ OA studies are generally titled by the year beyond the year of the study execution, e.g. OA '03 was conducted in 2002, etc.

⁹ “The Director of Program Analysis and Evaluation (D, PA&E), in coordination with the Heads of the DoD Components, shall . . . Establish, chair, and provide administrative support to the JADMSC. . . With the Chairman of the Joint Chiefs of Staff, prepare annually an integrated multiyear program for developing analytical baselines for use in strategic analyses, based upon scenario priorities identified by the Under Secretary of Defense for Policy (USD(P)).” (DoDI 8260.2, 5.1, 5.1.2, 5.1.3)

¹⁰ “The DoD Components shall review the JDS data repository holdings for which they are responsible, and update the data and metadata when events warrant such changes. Assessment and revision of data are particularly important upon receipt of a revised threat assessment (normally every 24 months but, in some cases, more frequently).” (DoDI 8260.2, 6.3.6.2)

¹¹ “The Heads of the DoD Components shall . . . Implement procedures to generate data for development of analytical baselines . . . Provide the Component-specific data, based on content identified by the Director of Program Analysis and Evaluation, necessary to develop the analytical baselines . . . Participate in the development of the analytical baselines, ensuring data are applied in the correct context to support each baseline developed.” (DoDD 8260.1, 5.4)

¹² “The Director of the Defense Intelligence Agency . . . in coordination with the Heads of the DoD Components, shall provide timely, integrated, and validated non-U.S. data to support the development of baselines for strategic analyses.” (DoDD 8260.1, 5.5)

¹³ “Components are expected to use [future year analytical baselines] as the starting point for analyses supporting planning, programming, and acquisition efforts.” (D,PA&E Memorandum to DoD components, September 27, 2005)



This page intentionally blank.

Appendix D: The Functional Capability Board Process and the Joint Capabilities Integration and Development System (JCIDS)

The Functional Capability Board Process includes, but goes beyond JCIDS. It is the decision support process which enables the Chairman of the Joint Chiefs of Staff, assisted by the Joint Requirements Oversight Council (JROC), to fulfill the responsibilities under Title 10, United States Code, sections 113(g)(1), 153, and 163. The Chairman:

- a. Advises the Secretary of Defense (SecDef) on the priorities of capabilities identified by combatant commands.
- b. Advises the SecDef on the extent to which program recommendations and budget proposals of the Military Departments and other components of the Department of Defense (DOD) conform with the priorities established in strategic plans and combatant command-prioritized capability needs.
- c. Submits to the SecDef alternative program recommendations and budget proposals, within projected resource levels and guidance provided by the SecDef, in order to achieve greater conformance with these priorities.
- d. Advises the SecDef on the extent to which the major programs and policies of the Armed Forces conform to strategic plans.
- e. Assesses military capability needs for defense acquisition programs.¹

Title 10, USC, section 181, directs the Secretary of Defense to establish the Joint Requirements Oversight Council (JROC). In addition to other matters assigned to it by the President, Secretary of Defense or Chairman, the JROC:

- a. Assists the Chairman in identifying and assessing the priority of joint military capability needs (including existing systems and equipment) to meet national military and defense strategies.
- b. Assists the Chairman in considering alternatives to any acquisition program that has been identified to meet military capability needs by evaluating the cost, schedule and performance criteria of the program and of identified alternatives.
- c. Assists the Chairman in assigning joint priority among existing and future programs meeting valid capability needs, and ensures that the assignment of such priorities conforms to, and reflects, resource levels projected by the SecDef.
- d. Assists the Chairman in fulfilling functions identified in title 10 sections 153 and 163, to include formulation of programmatic and budgetary advice to the SecDef.²

“The FCBs (via the Joint Capability Board – JCB) provide analytic support for JROC discussions and decisions on capability needs, joint concepts, and programmatic issues.”³ JCIDS is informed by, but does not specifically address issues involving joint concepts.

JCIDS

The Joint Capabilities Integration and Development System (JCIDS) replaced the Requirements Generation System in June 2003. CJCSI 3170.01 series instructions established JCIDS and CJCSM 3170.01 set forth guidelines and procedures for its

operation. The governing instruction for JCIDS was revised three times in its first three years of implementation, and a fourth revision is currently being staffed. The May 2005 issuances of the JCIDS Instruction and Manual describe JCIDS as a “top-down capabilities identification methodology,” in which the JOpsC family of joint future concepts is used to underpin investment decisions leading to the development of new capabilities beyond the FYDP.

In its intended implementation, JCIDS consists principally of Capability-Based Assessments (CBAs) resulting in a set of capability documents that support acquisition activities. This appendix focuses upon CBAs and the information that JCIDS must provide to allow the Chairman to submit “to the Secretary alternative program recommendations and budget proposals, within projected resource levels and guidance provided by the Secretary, in order to achieve greater conformance with priorities”⁴ “established in strategic plans and with the priorities established for the requirements of the specified and unified commands.”⁵ The documents used in acquisition processes and to support the related Chairman’s and JROC Title 10 responsibilities include Initial Capabilities Documents (ICDs) [formerly Mission Needs Statements – MNS], Capability Development Documents (CDDs) [formerly Operational Requirements Documents – ORDs], and Capability Production Documents (CPDs). Appendix F contains additional description of the role of JCIDS documents in acquisition processes.

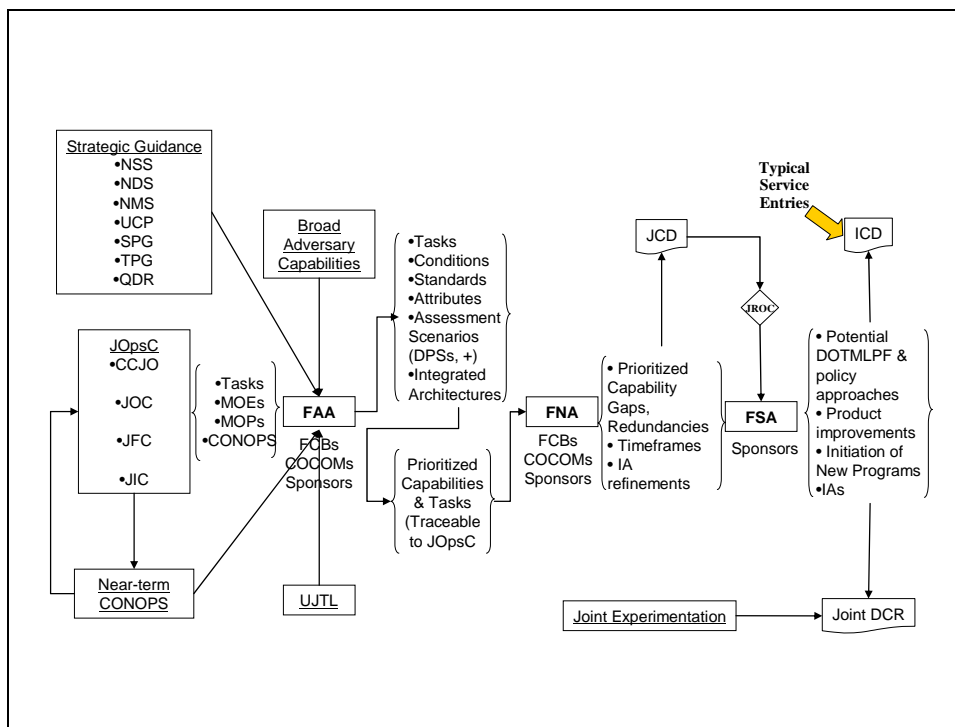

Figure D.1: JCIDS Capability-Based Assessment Process

Figure D.1 depicts the JCIDS CBA process as described in CJCSI 3170.01E. This process is built around what are called Functional Area Analyses (FAA), Functional Needs Analyses (FNA), and Functional Solution Analyses (FSA). The FAA and FNA portions of CBAs are to be performed by FCBs, combatant commands (COCOMs), and sponsors.⁶ A

“sponsor” is a term of art in JCIDS, described as, “the DOD component or other organization responsible for all common documentation, periodic reporting and funding actions required to support the JCIDS process and acquisition activities.”⁷ Only those organizations that have acquisition authority can perform the functions required of a sponsor, which means that the Services and Combat Support Agencies serve as sponsors, with some exceptions – principally for non-material solutions.

Functional Area Analysis. Inputs to the FAA include: strategic guidance, joint concepts (in the form of both the family of future joint concepts and near-term CONOPS derived from “strategic concepts” in COCOM plans, Service and Agency concepts, and any others that the analytical team chooses to consider), broad adversary capabilities from intelligence projections,⁸ and tasks from the Universal Joint Task List (UJTL) related to the “function” under analysis. As described, the family of future joint concepts is intended to provide the tasks to be performed, measures of effectiveness (MOEs), measures of performance (MOPs), and CONOPS to be used in the FAA. Though not described in JCIDS instructions, the DoD Analytic Agenda is intended “to develop, in a joint, transparent, collaborative manner, appropriate, up-to-date, traceable, and integrated baselines [packages consisting of a scenario, concepts of operation, and integrated data] suitable for strategic analyses,”⁹ which should be considered in initiating a CBA. (Also see Appendix C.)

The outputs of the FAA are described as the operational tasks, conditions and standards needed to achieve military objectives, and attributes required of the capability. The FAA identifies the scenarios against which the capabilities and attributes will be assessed. Scenario sources include, but are not limited to, the Defense Planning Scenarios (DPSs) published by the Office of the Secretary of Defense (OSD). The FAA produces a prioritized list of capabilities and tasks necessary to achieve the military objectives. The capabilities and their attributes should be traceable to the JOpsC family of joint future concepts and any other supporting information used to develop the capabilities. These capabilities form the basis for integrated architectures and will be reviewed in the follow-on FNA.

Functional Needs Analysis. The FNA assesses the ability of the current and programmed warfighting systems to deliver the capabilities the FAA identified under the full range of operating conditions and to the designated measures of effectiveness. Using the capabilities and tasks identified in the FAA as primary input, the FNA produces a list of capability gaps that require solutions and indicates the time frame in which those solutions are needed. It may also identify redundancies in capabilities that reflect inefficiencies. The FNA also should provide the relative priority of the gaps identified. The FNA serves to further define and refine the integrated architectures. The FNA must assess the entire range of DOTMLPF and policy, as an inherent part of defining capability needs.

The results of an FNA are documented in a Joint Capabilities Document (JCD). The JROC validates JCDs and tasks sponsors with performing follow-on FSAs and the development ICDs when appropriate. Multiple ICDs or joint DOTMLPF Change Recommendations (DCRs), for solutions that do not require significant technology development or new material, may result from one JCD. In addition to high-priority capability gaps, JCDs are supposed to identify areas where risks may be taken.

Functional Solutions Analysis. The FSA is an operationally based assessment of all potential DOTMLPF and policy approaches to solving (or mitigating) one or more of the capability gaps identified in the JCD. On the basis of the capability needs, potential approaches are identified, including (in order of priority) integrated DOTMLPF and policy changes that leverage existing materiel capabilities; product improvements to existing materiel or facilities; adoption of interagency or foreign materiel solutions; and initiation of new materiel programs. The completed FSA documents the capability gaps and alternative approaches and includes more detailed integrated architectures linking the approaches to existing systems. Identified capability needs or redundancies (excess to the need) establish the basis for developing non-materiel and/or materiel approaches as documented in an ICD and/or joint DCR.¹⁰

The accompanying Chairman's Manual elaborates on the above, and adds some important new provisions, as follows:

The first step in the JCIDS analysis begins when the combatant command, FCB or sponsor leads performance of an FAA [previously, only a sponsor could lead an FAA]. The FAA can be self-initiated by a sponsor or combatant command based upon an approved concept of operations (CONOPS). The FAA may also be initiated at JROC direction based upon the family of joint future concepts. . .

. . . The combatant command, FCB or sponsor performs the FNA following the FAA [previously, only a sponsor could lead an FNA]. While it may be led by a sponsor, the FNA should always be a joint collaborative effort to include the combatant commands, FCBs and other Services and agencies, as appropriate, to ensure a joint analysis of capabilities and determination of gaps. The FNA assesses the ability of the current and programmed joint capabilities to accomplish the tasks, under the full range of operating conditions and to the designated standards that the FAA identified and serves to further define and refine the integrated architectures. . .

. . . The sponsor leads the FSA with support from the combatant commands and oversight by the FCBs. Applicable integrated architectures shall be considered in the development of the FSA. FSA outputs will identify potential approaches to resolve identified capability gaps. . . . The approaches identified should include the broadest possible range of joint and independent possibilities for solving the capability gap.¹¹

Functional Capabilities Boards (FCBs)

The FCB Process was established by a Chairman's Instruction issued in November 2004. This directive states that (1) FCBs are established according to functional areas; (2) the JROC determines which FCBs will be established, disbanded or combined; (3) the JROC determines which specific area(s) are assigned to each FCB and the lead organization(s) responsible for sponsoring the FCB; and (4) the Vice Director, J-8 approves FCB portfolios inside each functional area.

The mission of FCBs includes providing assessments and recommendations that enhance capabilities integration; examining joint priorities among existing and future programs; assessing program alternatives; and minimizing duplication of effort throughout the Services. Each FCB evaluates issues that impact its functional area and provides

subject matter expertise and input to the JROC and JCB for JCIDS and non-JCIDS activities.

FCBs develop and maintain the Joint Functional Concepts (JFCs) and assist in the development of attributes, assumptions, measures of effectiveness and standards that support JCIDS. FCBs continually assess their JFCs and relationships with other concepts. FCBs ensure that proposed capability approaches are examined for their potential to improve joint operations. Sponsors must complete JCIDS analysis (FAA/FNA/FSA) before forwarding proposals for review.

Challenges in implementing JCIDS

Implementing major changes in well-developed processes brings challenges, and JCIDS has had its share. The principal difficulty has been in attempting to transition from programs as the basis for senior decisions to capabilities which are implemented in the form of programs.

The stated logic is that concepts drive the assessment of capabilities, and portfolios of programs provide those capabilities. In fact, as shown in Figure D.1, the Services, with their individual capability development planning processes, predominately enter the system with “JCIDS proposals” in the form of ICDs (formerly MNS).¹² In the past, most MNS were written to provide the background to initiate a procurement program that the Services had in mind. This remains the driver of JCIDS today, overwhelming the FCBs and the Services in conducting processes that do not affect the generation of programs. Without prioritization, the Service program proposals generate far more items for staffing than the JROC has time on its agenda to address. The staff work with no decision has resulted in frustration both on the FCBs and with those trying to move their proposals through a process that does not have the capacity to deal with them.

In theory, CBAs are conducted on validated concepts. In practice, CBAs have resulted from:

- Operational shortcomings
- Perceived future needs
- Unified looks at mission areas (undersea superiority, forced entry operations, etc.)
- Joint examination of an operational concept provided by a particular community (Service)
- Broad examination of a functional area (joint distribution – a subset of joint logistics)¹³

Even the broadest of functional area examinations has yet to cover the full portfolio of capabilities, tasks, and programs associated with an FCB. In practice, alternative concepts for conducting operations are a way to provide an enhanced capability to mitigate a gap, thus more of an output of a cyclical process with feedback, rather than a starting point.

CJCSI 3137.01C directs the FCBs to “Develop and maintain portfolios to assist in managing capability issues and documents.”¹⁴ Identifying what constitutes an FCB

portfolio, how these portfolios relate to efforts to map programs to capabilities, methods for prioritizing capabilities, identifying trade offs to support allocating resources to emerging priorities, and then managing the fielding of systems that both work in the context of “families of systems” or “systems of systems” and are delivered on a schedule that provides the requisite end-to-end capability, are all works in progress.¹⁵

Another major challenge has been in the selection of a sponsor who could or would examine a broad spectrum of possible solutions, uninfluenced by Service or Agency particular responsibilities and regard for its priority programs. The direction to produce elements such as integrated architectures has vacillated in different versions of the instruction.

In short, the JCIDS and FCB directives have been aspirational and very difficult to implement as they attempt to preserve all detailed program planning in the context of broad capability assessment. The directives call for far more than FCBs, staffed principally by officers and civilians as a collateral duty, can perform, and far more than the JROC can address. As the staff of the JROC, the Vice-Chairman, and the Chairman for responsibilities beyond the JROC, the principal purpose of FCBs should be conducting the staffing on issues for decisions that the JROC, Vice-Chairman, and Chairman must make. Increasingly efforts are aimed at not performing details of the JCIDS process just to perform the process, but only when it affects a decision and an outcome.

End Notes

¹ CJCSI 3137.01C, The Functional Capabilities Board Process, November 12, 2004, p. 1.

² Ibid, p. A-1.

³ Ibid, p. B-1

⁴ Title 10, United States Code, section 153a(4)(C)

⁵ Title 10, United States Code, section 153a(4)(B)

⁶ “Within the JCIDS process, the sponsor is expected to:

a. Lead the JCIDS analyses (including the FAA, FNA and FSA) required when developing the ICD, while engaging and collaborating with appropriate organizations. The sponsor should work closely with the appropriate FCBs during the analysis process to ensure the analysis is truly joint.

b. Perform FSAs and develop ICDs as directed by the JROC for capability gaps identified in JCDs.

c. Provide support to combatant commands, CSAs and FCBs in developing JCDs.

d. Make affordability determinations in the evaluation of various approaches to delivering capabilities to the warfighter.

e. Develop JCIDS documentation as specified in this instruction and present this documentation for review through the KM/DS tool.

f. Resolve issues that arise during the staffing, certification and validation processes. All comments will be adjudicated prior to JCB and JROC briefings. Unresolved critical comments will be briefed to the JCB or JROC for decision.

g. When the system contributes to FoS or SoS capabilities, coordinate with sponsors of the related joint DCRs, CDDs and CPDs to synchronize development and delivery of the systems and required overarching DOTMLPF and policy changes.

h. Present briefings to decision bodies, as required.

i. Validate Joint Integration documents after receiving required certifications and validate all Independent designated documents.

j. Coordinate/collaborate with non-DOD agencies and departments on the development of interagency capabilities.

k. Develop a CDD, CPD or joint DCR, as appropriate, to support the acquisition or fielding of a capability demonstrated through an ACTD or ATD.

l. When the sponsor disagrees with the assigned JPD, appeal to the FCB or the Gatekeeper by providing a memorandum with justification for changing the JPD.

m. If a munition is not IM-compliant, the sponsor will request the JROC to approve a waiver of the IM requirements.” CJCSI 3170.01E, Joint Capabilities Integration and Development System, May 11, 2005, pp. B-3&4.

⁷ Ibid, p. A-6

⁸ Broad capabilities are considered to distinguish between “capability” and “threat”-based planning. The intent is to consider a sufficient set of potential adversaries, not to ignore specific threats on which we have good intelligence. This has been one point of confusion in implementing CBP.

⁹ DoDD 8620.1, 2002, p. 3.

¹⁰ CJCSI 3170.01E, pp. A-3 through A-5.

¹¹ CJCSM 3170.01B, pp. A-1 through A-4.

¹² Individual Service capability development planning processes include:

a. Army: Army Force Development Process

b. Air Force: Capabilities Review and Risk Assessment

c. Navy: Navy Capabilities Development Process

d. Marine Corps: Expeditionary Force Development Process

Diagrams of each show ICDs as the output of the processes.

¹³ “White Paper on Conducting Capability-Based Assessment (CBA) Under the Joint Capabilities Integration and Development System (JCIDS),” JCS J-8/Force Application Assessment Division, January 2006.

¹⁴ CJCSI 3137.01C, p. B-4.

¹⁵ USD(AT&L)’s Matrix Mapping Tool, D,PA&E’s Data Warehouse, the Joint Staff’s PROSITE tool, and the Linking Plans to Resources Methodology developed at USPACOM, all developed independently in recognition of a need to link capability assessments to resource allocation, offer partial solutions.



This page intentionally blank.

Appendix E. Joint Concept Development

Introduction

A concept is described by the Chairman of the Joint Chiefs of Staff as a notion or statement of an idea – an expression of how something might be done. How something *might* be done is what drives capabilities-based planning:

A capabilities-based model – one that focuses more on how an adversary **might fight** rather than specifically whom the adversary might be or where a war might occur – broadens the strategic perspective. It requires identifying the capabilities that US forces will need to defeat adversaries who will rely on surprise, deception, and asymmetric warfare to achieve their objectives. Moving to a capabilities-based force also requires the United States to focus on emerging opportunities that certain capabilities . . . **can confer** on the US military over time.

Secretary Donald H. Rumsfeld
Quadrennial Defense Review Report 2001¹
(Emphasis added.)

This appendix examines the role played by concepts in capabilities-based planning. It traces the top-down guidance that has shaped both the concept development process and the way concepts are used in capabilities-based assessments and offers commentary on the extent to which the guidance has or has not been followed.

Strategic Guidance for Developing and Using Future Joint Concepts

Quadrennial Defense Review 2001 (QDR-01) announced the shift to a "capabilities-based" model and called for a transformation of US forces based on operational concepts and capabilities. The QDR established four "pillars of transformation" – one of which was "experimenting with new approaches to warfare, operational concepts and capabilities, and organizational constructs . . . through wargaming, simulations, and field exercises focused on emerging challenges and opportunities." To foster innovation and experimentation, QDR-01 directed the establishment a new Office of Force Transformation (OFT), to report directly to the Secretary and Deputy Secretary of Defense.²

Defense Planning Guidance for Fiscal Years 2004-2009 (DPG-04) tasked the Under Secretary of Defense for Policy, in collaboration with the Joint Staff, Services, JFCOM, and OFT, to prepare Transformation Planning Guidance for the Secretary's approval.³

Transformation Planning Guidance (TPG), issued by Secretary Rumsfeld in April 2003, described a strategy for implementing transformation. Central to the strategy was balancing the requirements of current operations against investments in capabilities needed to support future operating concepts. This part of the strategy had two elements:

- Reform of the requirements system to better identify and assess specific options for mitigating future risks, to be accomplished by investing in transformational capabilities based on joint operating concepts.

- A transformed analytic capability that accounts for greater uncertainty in threats and capabilities and is capable of comparing risks across time and between multiple theater-level operations.

Declaring that “the key to the Department’s transformation strategy is future joint operating concepts,” the TPG made the Chairman responsible for producing and validating authoritative joint concepts in three timeframes, as specified below:

- Near-term (2-3 years out) Joint Operations: Combatant commander war plans, operational and training lessons learned, and joint doctrine, all designed to achieve new strategy goals and updated in accordance with the Contingency Planning Guidance (CPG), would promote transformation through enhanced jointness and planning modifications. Combatant commanders would devise war plans taking into account mid-term joint operating concepts, lessons learned from ongoing operations, joint training and exercises, advanced concept technology demonstrations (ACTDs) and experiments. Current war plans and joint doctrine would be the authoritative baseline against which joint training and experimental results would be measured to assess their transformational value.
- Mid-term (just beyond the FYDP) Joint Concepts: Future joint concepts would depict how the joint force of the future is to fight, addressing specific military operations across the range of military operations.
 - The Chairman, in coordination with Commander, JFCOM, was tasked to develop one overarching joint concept and oversee development of subordinate joint operating concepts (JOCs) addressing four specified operations: (1) homeland security, (2) stability operations, (3) strategic deterrence, and (4) major combat operations. JOCs would evolve to reflect insights gained from experimentation, and transformation roadmaps would identify the capabilities needed to implement the JOCs and the preferred means of obtaining those capabilities. The TPG said the Department would measure progress toward building these capabilities in the program/budget review.
 - Integrated architectures would describe in greater detail the relationships between tasks and activities that generate effects on enemy forces, identifying where operations intersect and overlap and providing details on interoperability requirements. The architectures were to include not just materiel solutions but also doctrine, organization, and training needs. Using these architectures, the JROC would be responsible for prioritization of capabilities based on their contribution to realization of the JOCs.
- Far-term (15-20 years out) Joint Vision: The Joint Vision document (JV 2020, published in June 2000) was to be modified and used as a long-range articulation of joint operations, providing a broad statement of desired future concepts and capabilities required for future operations. The Joint Vision also would provide the context for future joint and Service concept development and experimentation.⁴

Two months after guidance from the Secretary defined mid-term concepts as “just beyond the FYDP” and defined the Chairman’s Joint Vision document as the long-range (15-20 years out) articulation of joint operations, new directives from the Chairman pushed

joint concepts 15-20 years out, leaving an apparent void “just beyond the FYDP.” The first JOpsC, approved by the Secretary in November 2003, described “how the Joint Force intends to operate within the next 15 to 20 years.” The four JOCs tasked by the TPG, published between February and September 2004, were “focused on the time horizon just beyond the FYDP, roughly 2015.” FYDP 2006-2011 was developed in 2004 and its corresponding budget submitted to Congress in February 2005. FYDP 2008-2013 and its budget will be submitted in February 2007. While claiming to be focused “just beyond the FYDP,” the first round of JOCs in reality were set two FYDPs into the future.

JCIDS and Joint Concepts

The initial set of directives governing JCIDS (CJCSI 3170.01C and CJCSM 3170.01, both issued in June 2003) together described how future joint concepts would be used to determine future capability needs. The directives identified three types of future concepts, defined as follows:

Joint Operations Concepts (JOpsC) – A concept that describes how the Joint Force intends to operate 15 to 20 years from now. It provides the operational context for transformation of the Armed Forces of the United States by linking strategic guidance with the integrated application of Joint Force capabilities.

Joint Operating Concept (JOC) – An articulation of how a future joint force commander will plan, prepare, deploy, employ, and sustain a joint force against potential adversaries’ capabilities or crisis situations specified within the range of military operations. JOCs guide the development of Joint Functional Concepts to provide joint capabilities. They articulate the measurable detail needed to conduct experimentation and allow decision makers to compare alternatives.

Joint Functional Concept (JFC) – An articulation of how a future joint force commander will integrate a set of related military tasks to obtain capabilities required across a broad range of military operations. Although broadly described within the JOpsC, they derive specific context from the JOCs and promote common attributes in sufficient detail to conduct experimentation and measure effectiveness.⁵

JOCs and JFCs, together with national strategy documents, integrated architectures and the Universal Joint Task List (UJTL), would serve as input to a Functional Area Analysis (FAA), the purpose of which was to identify the operational tasks, conditions, and standards needed to achieve military objectives. These tasks would be reviewed in the follow-on Functional Needs Analysis (FNA), an assessment of the ability of the current and programmed force to accomplish the tasks the FAA identified, under the full range of operating conditions and to the designated standards. Using the tasks identified in the FAA as primary input, the FNA would produce a list of capability gaps or shortcomings that require solutions, and would indicate the time frame in which those solutions would be needed.⁶

JCIDS was intended to implement, *inter alia*, the “Prioritization of joint warfighting capability gaps based on future joint concepts to help focus the efforts of solution developers.”⁷ However, two additional terms defined in the JCIDS directives reveal why the promised “prioritization of joint warfighting capability gaps” never materialized:

functional area – A broad scope of related joint warfighting skills and attributes that may span the range of military operations. Specific skill groupings that make up the functional areas are approved by the JROC.

sponsor – The DoD component responsible for all common documentation, periodic reporting, and funding actions required to support the capabilities development and acquisition process for a specific capability proposal.⁸

JCIDS directives originally specified that both the FAA and FNA would be led by a sponsor, by definition a DoD component able to support acquisition. This ruled out combatant commands, because except for USSOCOM (and to a limited extent USJFCOM), no combatant command has acquisition authority or funding.

The definition of “sponsor” also tied JCIDS analyses to specific capability proposals. Rather than identifying capability needs by “functional area” as the term Functional Area Analysis would imply, sponsors were to initiate a narrowly scoped analysis to support a specific capability proposal – without a complete, holistic assessment that would indicate where it ranked in priority compared to other needs.

In March 2004 the JCIDS directives were revised. A Functional Area Analysis led by a sponsor remained the first step in a JCIDS analysis, but the list of inputs to the FAA was expanded to include JOCs, JFCs, and the new Joint Integrating Concept, defined as follows:

Joint Integrating Concept (JIC) – A JIC describes how a joint force commander integrates functional means to achieve operational ends. It includes a list of essential battlespace effect (including essential supporting tasks, measures of effectiveness, and measures of performance) and a CONOPS for integrating these effects together to achieve the desired endstate.⁹

Strategic Planning Guidance for Fiscal Year 2006-2011 (SPG-06), also issued in March 2004, included the following guidance on developing joint concepts:

- The key to developing a wider range of future capabilities and identifying shortfalls is strategy-driven joint *operating*, *integrating*, and *functional* concepts. These concepts depict how future forces will conduct operations and identify and prioritize the capabilities needed to execute the operations.
- The overarching Joint Operating Concepts (JOpsC) is supported by four cornerstone JOCs. Each requires different sets of supporting integrating concepts. These integrating concepts are the building blocks of future joint warfighting concepts and describe how specific operations will be conducted.
- The Chairman will develop a prioritized list of integrating concepts required to support the JOCs; designate them as either “born joint” or “Service led” (where a single Service has primary responsibility); and assign them to the Services and combatant commands for development. The following integrating concepts shall be included in the list and developed prior to the next QDR: (1) forcible entry operations, (2) urban operations, (3) information operations, (4) sea-basing operations, and (5) global strike operations.
- The Chairman will present to the Secretary a plan for revisions to future joint concepts, identifying the essential criteria of a joint concept and proposing a

method for ensuring they have enough specificity to allow logical linkages to joint integrated architectures.¹⁰

The National Military Strategy of the United States, signed by the Chairman in May 2004, included a footnote that said “The NMS integrates the document formerly known as “Joint Vision.”¹¹ Neither JV 2010 nor JV 2020 has ever been officially superseded or canceled, but the role of the Joint Vision document envisioned in the TPG – as “a long-range articulation of joint operations, providing a broad statement of desired future concepts and capabilities required for future operations” – was effectively ended. Without a joint vision to guide capabilities development in the far term, joint concepts had to be pushed farther into the future.

The *Joint Concept Development and Revision Plan (JCDRP)* was prepared by the Joint Staff in response to the SPG-06 tasking in the last bullet above. The Chairman endorsed the plan and forwarded it for the Secretary’s approval on 30 July 2004, but the document apparently never made it to the Secretary. The Joint Staff elected to act as if it had been approved, and began drafting a new Chairman’s Instruction to implement the plan. At least five drafts were circulated for comment, and the question of time frames – how far to peer into the future – was not settled right away.

The JCRDP defined the JOpsC, JOCs, JFCs, and JICs as descriptions of joint warfare 10-20 years in the future, as did an April 2005 draft of the Chairman’s Instruction.¹²

A June 2005 draft took a more expansive view, explaining that:

Joint Concepts can be written for any timeframe (near/mid/far-term). For the purpose of this instruction, there is a differentiation based on the time frame the concepts are written. Joint Future Concepts are not to be confused with Concept of Operations (CONOPS) designed to address near term issues. CONOPS are ideas that address near-term issues within the FYDP. Near-term CONOPS allow the joint community to adjust or divest current capabilities by providing the operational context needed to solve current problems. For the purpose of this instruction, Figure A-1 [reproduced in Figure E.1, below] differentiates timeframes for near, mid and far term concepts in the context of enemy and friendly capabilities.

	Within the FYDP	Beyond FYDP-14 yrs	15-20 years
Concepts	Near-term CONOPS	Mid-term Future Concepts	Far-term Future Concepts
Enemy Capabilities	Known	Known to Postulated	Postulated
Blue Capabilities	Adjust Current Capabilities/Divest Old Capabilities	Adjust Current/ POM New / Divest Old Capabilities	New Capability Development

Figure E.1

Near term CONOPS are developed outside the purview of this instruction but have direct influence on mid and far term Joint Future Concepts through their development and identification of Future Joint Force needs beyond the near term.¹³

It was noted above that combatant commanders were expected to devise their war plans based on joint doctrine while at the same time taking into account the mid-term joint operating concepts. The above passage indicates the relationship was meant to be iterative: joint operating concepts influence near-term CONOPS and near-term CONOPS influence mid- and far-term joint concepts.

The text just above the figure suggested that near-term CONOPS allow the joint community to adjust or divest current capabilities by providing the operational context needed to solve current problems. Future joint concepts and the future CONOPS included as part of each Defense Planning Scenario should do no less. In addition to these changes, the 1 June draft renamed what had been the Joint Operations Concepts (JOpsC) as the Capstone Concept for Joint Operations (CCJO) and applied the term JOpsC to describe the family of joint concepts.

The 1 August 2005 draft described the JOpsC family as concepts that “look from beyond the FYDP out to 20 years.”¹⁴ The final version approved in January 2006 established the time frame of the JOpsC family as covering “a period beyond the Future Years Defense Program, 8-20 years into the future.”¹⁵

The approved version also described the relationship of the JOpsC family of joint concepts to JCIDS, and how Concepts of Operations (CONOPS) and Defense Planning Scenarios (DPSs) are used to determine capability needs, as follows:

- a. Military capabilities derived from JOpsC family development *may be* entered into the JCIDS analysis process to determine gaps, redundancies, and potential DOTMLPF and policy solutions [italics added].
- b. As defined in Joint Publication 1-02, CONOPS is a verbal or graphic statement, in broad outline, of a commander’s assumptions or intent in regard to an operation or series of operations. The CONOPS is frequently embodied in campaign plans and operation plans; in the latter case, particularly when the plans cover a series of connected operations to be carried out simultaneously or in succession. The CONOPS is designed to give an overall picture of the operation. It is included primarily for additional clarity of purpose.

(1) For JOpsC family development, CONOPS are used to provide the overall understanding of an operation and the broad flow of tasks assigned to subordinate and/or supporting entities. It presents a joint force commander’s plan that synchronizes military capabilities to accomplish the mission for a specific scenario 8-20 years into the future. CONOPS focus on describing the streams of activities and how the joint force commander might organize and employ forces to accomplish those activities. CONOPS used in the JOpsC family development process are based on DPS or illustrative vignettes:

- (a) Defense Planning Scenarios. DPSs, written 8-20 years into the future, are used in CBA. These scenarios have classified CONOPS that provide a high level of specificity and defined parameters to aid in robust analysis of capabilities and a comparison of alternate solutions.
- (b) Illustrative Vignettes. When used in JOpsC, illustrative vignettes provide operational context to describe how a joint force commander

might organize and employ forces 8-20 years into the future. These vignettes are used to clarify and increase understanding of the concepts.

(2) As they relate to JCIDS, CONOPS have a different use. CONOPS, as described in CJCSI 3170 JCIDS series are written to describe how a joint force commander may organize and employ forces in the near term (now through 7 years into the future) in order to solve a current or emerging military problem. These CONOPS provide the operational context needed to examine and validate current capabilities and may be used to examine new and/or proposed capabilities required to solve a current or emerging problem. These CONOPS and the appropriate assessment results are coordinated with the appropriate Functional Capabilities Board (FCB) and its capabilities are submitted to Joint Staff/J-8 as potential joint capabilities documents (JCDs).¹⁶

Joint Operations Concepts Development Process

CJCSI 3010.02B was approved by the Chairman in January 2006. Figure E.2 is a schematic that illustrates the concept development process described in this instruction. Strategic guidance, documents describing the postulated operational environment, and the results of joint experimentation feed into the development of the family of operational concepts. Lessons derived from operations and exercises inform JOCs, JFCs, and JICs. The JOCs and JFCs, in turn, inform the development of DPSs, which provide assumptions used in the formulation of JICs. The JICs then provide the tasks, conditions, and standards and vignettes to inform CBAs, which also use DPSs. The CBAs then lead to Joint Capability Documents (JCDs) and Initial Capability Documents – which are also informed by the family of joint concepts – leading to investment decisions (through the Concept Decision process).

Reviewing the graphical depiction of the process raises the question of whether JICs, as described, are functionally redundant with DPSs. The principal purpose of both is to provide sufficient context to identify tasks, conditions, and standards. A set of DPSs provides more complete context than a vignette in a JIC for conducting CBAs. This leads to the option, discussed in Chapter 4, of recasting the role of JICs to make them concepts for mitigating specific capability shortfalls (solving problems to be solved) or to take advantage to technological opportunities, which employ experimentation to be explored as part of the capability assessment process and refined during the concept refinement process before acquisition milestones A.

The absence of a defined science and technology input to the process is apparent in the diagram.

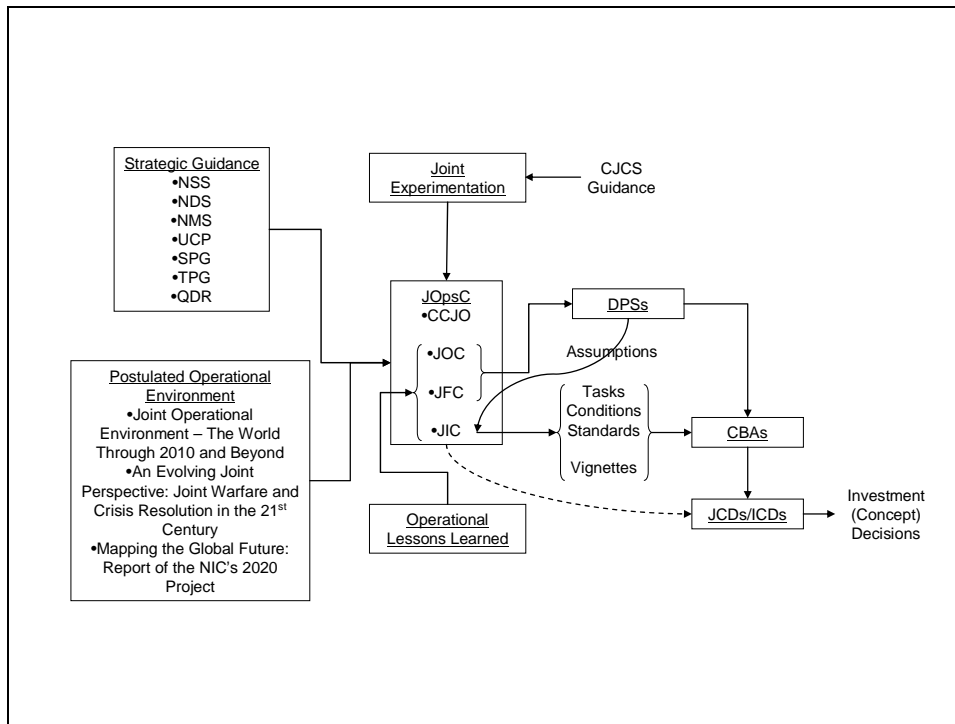

Figure E.2: Joint Operations Concept Development Process

End Notes

¹ Quadrennial Defense Review Report, September 30, 2001, p. 14.

² *Ibid.*, pp. 29, 32.

³ Defense Planning Guidance Fiscal Years 2004-2009 (U), May 2002, pp. 6, 49-50, 53-54.

⁴ Transformation Planning Guidance, April 2004, pp. 8, 15-16.

⁵ CJCSI 3170.01C, Joint Capabilities Integration and Development System, June 24, 2003, pp. GL-7 and GL-8.

⁶ CJCSM 3170.01, Operation of the Joint Capabilities Integration and Development System, June 24, 2003, p. A-2.

⁷ CJCSI 3170.01C, p. A-2.

⁸ CJCSI 3170.01C, pp. GL-6 and GL-10.

⁹ CJCSI 3170.01D, Joint Capabilities Integration and Development System, March 12, 2004, p. GL-8.

¹⁰ Strategic Planning Guidance for Fiscal Years 2006-2011, March 2004, pp. 24-25.

¹¹ The National Military Strategy of the United States of America: A Strategy for Today; A Vision for Tomorrow, May 2004, p. 3.

¹² Joint Concept Development and Revision Plan, July 2004, pp. 5-6; Draft CJCSI 3010.02B, Joint Future Concepts Employment Plan, April 1, 2005, pp. A-4 and A-5.

¹³ Draft CJCSI 3010.02B, Joint Future Concepts Process, dated June 1, 2005, pp. A-2 and A-3.

¹⁴ Draft CJCSI 3010.02B, Joint Operations Concepts (JOpsC) Program, dated August 1, 2005, p. A-1.

¹⁵ CJCSI 3010.02B, Joint Operations Concepts Development Process (JOpsC-DP), January 27, 2006, p. A-1.

¹⁶ CJCSI 3010.02B, January 27, 2006, pp. A-5 and A-6.

Appendix F. Acquisition

Introduction

This appendix provides a discussion of the defense acquisition process and its connections to other elements of Capabilities-Based Planning (CBP). The first section provides an overview of the Defense Acquisition System (as established in the DoD 5000 series of regulations), with considerable discussion of the major linkages to two other DoD decisions support processes: the Joint Capabilities Integration and Development System (JCIDS), and the Planning, Programming, Budgeting, and Execution (PPBE) process. The second section provides an overview of the DoD Science and Technology (S&T) program.

Defense Acquisition System

Current Acquisition Policies and Procedures

The Defense Acquisition System is the management process by which the Department acquires weapon systems, automated information systems, and other acquisition programs. Although the system is based on centralized policies and principles, it allows for decentralized and streamlined execution of acquisition activities. This approach provides flexibility and encourages innovation, while maintaining strict emphasis on discipline and accountability.

DoD Directive 5000.1, *The Defense Acquisition System*, provides the policies and principles that govern the defense acquisition system. The primary objective of defense acquisition is to acquire quality products that satisfy user capability needs associated with measurable levels of mission capability and operational support, in a timely manner, and at a fair reasonable price. Additional policies are provided in Enclosure 1 of the Directive.

DoD Instruction 5000.2, *Operation of the Defense Acquisition System*, in turn establishes the management framework that implements the policies and principles provided in the Directive. The defense acquisition framework shown in Figure 1 provides an event-based process where acquisition programs proceed through a series of milestones associated with significant program phases.¹ For each acquisition program, a senior official known as the Milestone Decision Authority (MDA) approves each entry into the next phase at each milestone decision point, consistent with phase-specific entrance criteria and statutory requirements. Details on each of the milestones and program phases are found in section 3 of the Instruction. The Instruction identifies the specific statutory and regulatory reports and other information requirements for each milestone and decision point.

The DoD 5000 series regulations are supplemented by the *Defense Acquisition Guidebook*. Although the recommended practices in the Guidebook are not mandatory for program managers, the Guidebook nevertheless provides considerable useful information reflecting the best business practices and lessons learned in meeting the requirements of the acquisition regulations.

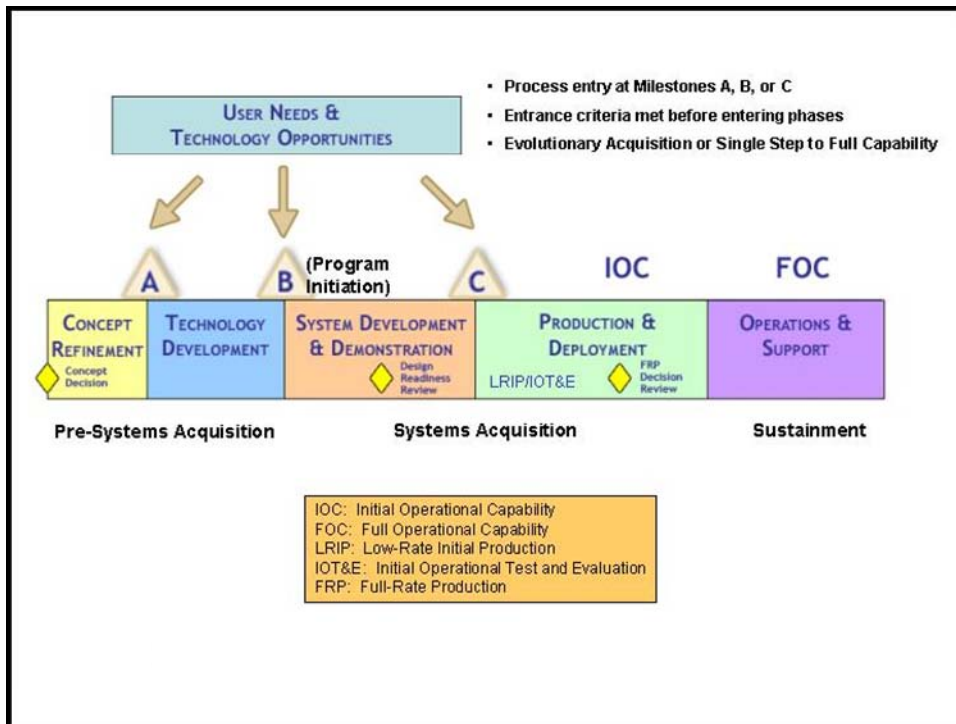

Figure F.1: Defense Acquisition Management Framework

Oversight of Acquisition Programs

One key principle of the defense acquisition system is that acquisition programs are stratified into categories where programs of increasing dollar value and management interest are subject to more stringent oversight. Specific dollar and other thresholds for these acquisition categories are contained in DoD Instruction 5000.2, *Operation of the Defense Acquisition System*, Enclosure 2. The most expensive programs are known as major defense acquisition programs (MDAPs) or as major automated information systems (MAISs). These major programs have the most extensive statutory and regulatory reporting requirements. In addition, some elements of the defense acquisition system are applicable only to weapon systems, some are applicable only to automated information systems, and some are applicable to both. Specific details are found in DoD Instruction 5000.2, Enclosure 3.

MDAPs or MAISs are subject to review by specific senior officials in the Office of the Secretary of Defense (OSD), unless delegated to a lower level of review (usually the appropriate DoD Component head or acquisition executive). For the programs reviewed at the OSD level, MDAPs are denoted as Acquisition Category (ACAT) ID and are subject to review by the Under Secretary of Defense for Acquisition, Technology, and Logistics (USD(AT&L)), and MAISs are denoted as ACAT IAM and are subject to review by the Assistant Secretary of Defense for Networks and Information Integration/Chief Information Officer (ASD(NII)/CIO).² Both individuals, serving as the MDA for their respective programs, are supported by advisory groups (known as the Defense Acquisition Board (DAB) and the Information Technology Acquisition Board (ITAB), respectively) consisting of senior officials from the Joint Staff, the Military Departments, and staff offices within OSD. Both the DAB and the ITAB are supported by a subordinate group in

OSD known as an Overarching Integrated Product Team (OIPT). Each OIPT facilitates communication and vets issues before the DAB or ITAB review meeting. In this role, the OIPT charters Working-level Integrated Product Teams (WIPTs) for each review and manages their activities. At the milestone decision point, the OIPT leader provides the DAB or ITAB members an integrated assessment of program issues gathered through the IPT process as well as various independent assessments.³

The responsibility for each acquisition program follows a streamlined chain-of-command where the MDA is the designated individual with overall responsibility for the program. The MDA has the authority to approve entry for an acquisition program into the next phase, and is held accountable for meeting program cost, schedule, and performance objectives. The Component Acquisition Executive (CAE) is the most senior acquisition official in the program's assigned military department or defense agency. The CAE reports directly to the MDA on all acquisition issues pertaining to the acquisition program. Reporting to the CAE is the Program Executive Officer (PEO). The PEO for a program is a senior acquisition professional who provides oversight and strategic direction to the program and other acquisition programs that are closely related. Finally, reporting to the PEO, the Program Manager (PM) is the designated individual with responsibility for and authority to accomplish program objectives for development, production, and sustainment to meet the user's validated capability needs. The PM serves as the leader of the Government-Contractor team responsible for program execution. The PEO, CAE, and MDA have the responsibility to ensure that the PM has the resources and guidance necessary to accomplish program goals.

Defense Acquisition and Joint Capabilities Integration and Development System

The Chairman of the Joint Chiefs of Staff (CJCS) has a major role to inform and advise the defense acquisition process by identifying, assessing, and prioritizing joint military capability needs; these identified and validated capability needs then serve as the guide for the development, production, and sustainment of acquisition programs. The process to support the Chairman in this role is described in CJCS Instruction 3170E, *Joint Capabilities Integration and Development Systems*. (Also see Appendix D in this report.) This instruction establishes the policies for JCIDS, and provides a top-level description of the process. A supplementary manual (CJCS Manual 3170.01B, *Operation of the Joint Capabilities Integration and Development System*) provides the details necessary for the day-to-day work in identifying, describing, and justifying joint warfighting capabilities. The manual also includes the formats that describe the content required for each JCIDS document.

A disciplined capability needs identification process, based on robust and rigorous analyses, is the key to achieving effective and timely acquisition within expected budgets. Users and operators are responsible for comprehensive, clear, and timely identification of capability needs through the JCIDS process. Program managers are responsible for supporting the JCIDS process by providing users and operators with timely and credible assessments of programmatic (cost, schedule, and technical) implications, risks, and tradeoffs in meeting capability needs.

For MDAPs or MAISs subject to OSD oversight, the products of the JCIDS process directly support the DAB or ITAB in advising the MDA for major milestone

decisions. Figure 2 is a simplified portrayal of the nature of this support. JCIDS provides similar support to other special joint interest acquisition programs, regardless of the MDA. Where appropriate, the JCIDS process and its products may be tailored when applied to automated information systems.

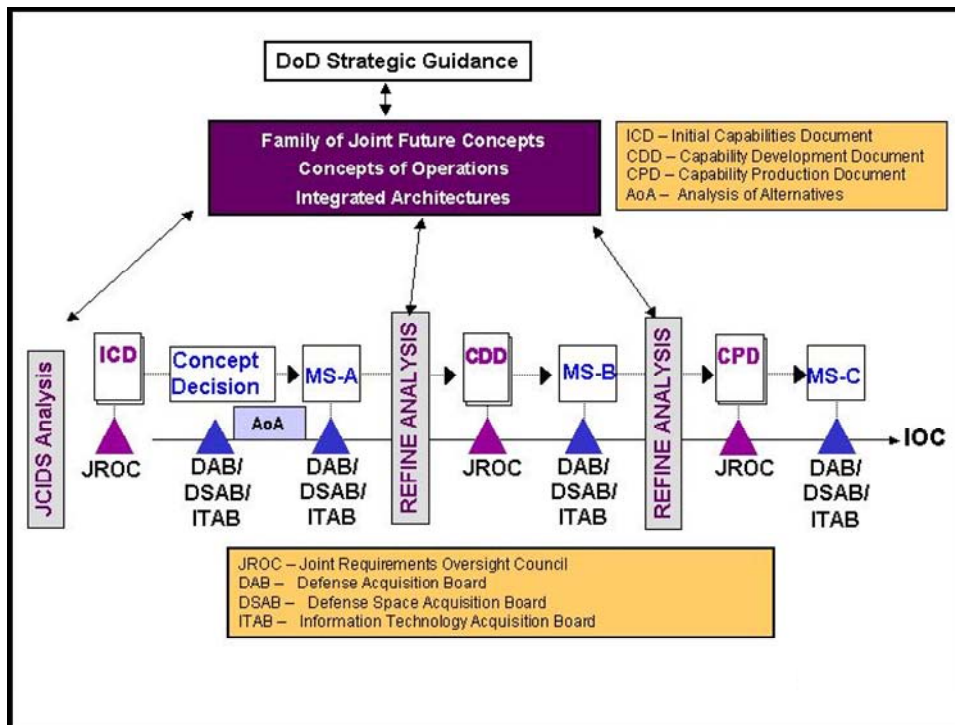

Figure F.2: JCIDS Process and Acquisition Decisions

There are several key points portrayed in Figure 2. First, JCIDS is based on a series of top-down analyses ultimately derived from formal strategic-level guidance, including the National Security Strategy, National Military Strategy, and the report of the Quadrennial Defense Review. Second, these analyses assess existing and proposed capabilities in terms of their contribution to emerging joint warfighting concepts. Moreover, rather than focusing on the capabilities of individual weapon systems in isolation, the analyses assess capabilities in the context of integrated architectures of multiple interoperable systems. Third, from these overarching joint concepts, the JCIDS analysis process identifies capability gaps or shortcomings, and assesses the risks associated with these gaps. These gaps may be addressed by a combination of materiel and/or non-materiel solutions (non-materiel solutions would be changes to doctrine, organization, training, leadership and education, personnel, and facilities). Fourth, recommended materiel solutions, once approved, lead to the initiation of acquisition programs. As these programs continue, JCIDS documents are provided at each acquisition milestone that will guide the subsequent development, production and testing of the program. Further information on the JCIDS analysis process, as well as the nature and role of each of the JCIDS documents, can be found in CJSCI 3170.01E, Enclosure A.

In the JCIDS process, the Chairman is supported by the JROC, which reviews and validates all JCIDS documents under its purview and, based on its review, makes

recommendations to the DAB or ITAB. JROC responsibilities are established by law (see Section 181 of Title 10, United States Code). The JROC is chaired by the Vice Chairman of the Joint Chiefs of Staff, who, importantly, also serves as the Vice Chairman of the Defense Acquisition Board. The other JROC members are the Vice Chiefs of each military service.

Role of Evolutionary Acquisition

DoDI 5000.2 describes the evolutionary acquisition approach for acquisition programs. In an evolutionary approach, the capability delivered to the user is provided in increments. Evolutionary acquisition strategies (1) define, develop, produce and deploy an initial, militarily useful capability (commonly referred to as Increment 1) based on proven technology, demonstrated manufacturing capabilities, and time-phased capabilities needs; and (2) plan for subsequent development, production and deployment of increments beyond the initial capability over time (Increments 2 and beyond). DoDI 5000.2 allows for two types of approaches to achieve evolutionary acquisition:

Spiral Development. The capability needs document(s) include a firm definition of the first increment, but the remaining interim increments and the precise end-state capabilities are not known at program initiation. The acquisition strategy defines the first increment of capability, and how it will be funded, developed, tested, produced, and supported. The acquisition strategy also describes the desired general capability the evolutionary acquisition is intended to satisfy, and establishes a management approach that will be used to define the exact capabilities needs for each subsequent increment.

Incremental Development. The capability needs documents(s) include a firm definition of the entire end-state capability, as well as firm definitions of interim increments, including an initial operating capability (IOC) date for each increment. In this case, the program acquisition strategy defines each increment of capability and how it will be funded, developed, tested, produced, and operationally supported.

Evolutionary acquisition is the preferred DoD strategy for rapid acquisition of mature and responsive capabilities to the user. The objective of evolutionary acquisition is to balance needs and available capabilities with given resources, and to provide capabilities to the users quickly. The success of the strategy depends on rigorous and continuous definition of capability needs, and the maturation of necessary technologies that lead to the disciplined development, production, and sustainment of systems that provide increasing capabilities towards the material concept. For each acquisition program, the JCIDS process and the defense acquisition system must work together to develop an affordable and sound evolutionary acquisition strategy.

JCIDS provides the foundation for the evolutionary acquisition approach to capability development. The JCIDS analysis known as the Functional Solution Analysis (FSA) includes an assessment of both materiel and non-materiel solutions that address the documented gaps in validated capability needs. The FSA results in an approved Initial Capabilities Document (ICD). The last step in the FSA is the analysis of materiel/non-materiel approaches (AMA). The AMA provides a prioritized list of materiel and non-materiel approaches (or combination of approaches) that is documented as part of the ICD. In this way, the ICD can be used to establish boundary conditions for the scope of

alternatives to be considered in the subsequent analysis known as the Analysis of Alternatives (AoA).

AoAs are an important element of the defense acquisition process. An AoA is an analytical comparison of the operational effectiveness, suitability, and life-cycle cost of alternative programs that satisfy established capability needs. The program office may provide assistance or data to the AoA study team, but the responsibility for the AoA should not be assigned to the program manager, and the study team members should not reside in the program office. Often, the AoA may be assigned to a federally funded research and development center or similar analytic organization. Further guidance and information about AoAs may be found in the *Defense Acquisition Guidebook*, Chapter 3, Section 3.3.

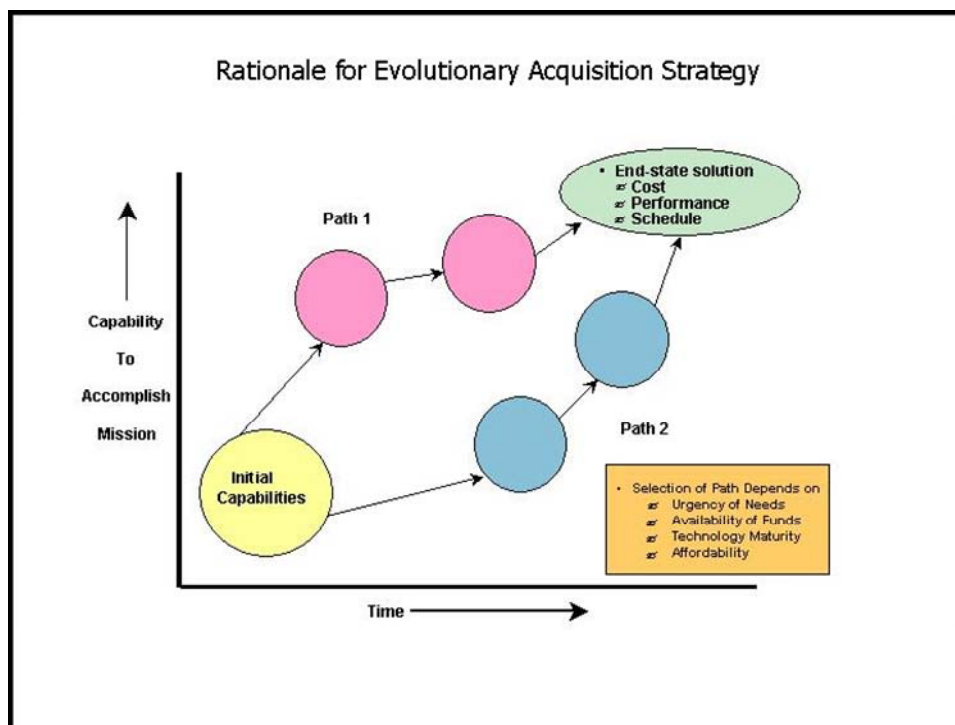

Figure F.3: Role of the ICD and AoA in Concept Refinement

The AoA process is expected to play a key role in support of the Concept Refinement phase (see DoD Instruction 5000.2, section 3.5). The approach to conducting the initial AoA is described in an AoA plan provided at the time of the concept decision milestone approval. Together, the ICD and the AoA plan guide the concept refinement. The focus of the subsequent AoA is to refine the selected concept documented in the approved ICD. The analysis of alternatives process is expected to contribute to the refinement of the initial concept and the identification of critical associated technologies, based on a balanced assessment of technology maturity and risk, and cost, performance, and schedule considerations (as shown in Figure 3). The results of the AoA provide the rationale for adopting a specific evolutionary acquisition strategy, which will be documented in the Technology Development Strategy, to be approved by the MDA at Milestone A for potential ACAT I and ACAT IA programs.

The Technology Development Strategy will provide a preliminary description of how the program will be divided into technology spirals and development increments, and specific cost, schedule, and performance goals and exit criteria that must be met for each technology spiral.

Acquisition Program Goals and Strategy

For acquisition programs, program managers are expected to formulate and document program goals, and develop the plans needed to achieve these goals. Program goals are the minimum number of cost, schedule, and performance parameters necessary to describe program objectives. Once the program goals are established, the program manager develops a document known as the Acquisition Strategy that summarizes the program planning and structure needed to achieve the goals.

Public law (see Section 2435 of Title 10, United States Code) requires each MDAP to establish a program baseline description that must include sufficient parameters (cost, schedule, performance, supportability, and any other factor) that describe the program over its life cycle. In DoD's implementation of this law, DoDI 5000.2 requires all acquisition programs to establish an Acquisition Program Baseline (APB) as part of the entrance criteria associated with a Milestone B review (i.e., approval to commence system development and demonstration). The APB contains program goals—objectives and thresholds—for the baseline cost, schedule, and performance parameters. The APB is prepared by the program manager, and approved by the PEO of the program. For all ACAT ID and IAM programs, the APB also must be approved by the CAE and MDA.

Objective values represent what the user desires and expects. The program manager manages the program to the objective value of each parameter as much as possible. Thresholds represent the acceptable limits to the parameter values that, in the user's judgment, still provide the needed capability. The baseline should only contain those parameters that, if thresholds are not met, would require the MDA to re-evaluate the program and consider alternative program concepts or design approaches. The use of objectives and thresholds provides a trade space that supports cost, performance, and schedule tradeoffs by the program manager without obtaining MDA approval. However, the program manager and user should work together on all trade-off decisions.

As stated earlier, the APB is submitted at the time of Milestone B approval. If necessary, the APB will be updated and submitted at the Milestone C review and the Full-Rate Production decision review. Normally, as the program matures, the objective and threshold values may be refined, based on technology and design trades made during the course of system development and demonstration, as well as improved cost and schedule information.

The performance section of the APB is extracted directly from the approved capability needs documents (i.e., Capability Development Document or Capability Production Document). Occasionally, the MDA may add performance parameters to the APB other than the JROC-validated key performance parameters. The schedule section of the APB is developed by the program manager, in coordination with the user and program sponsor. Schedule parameters include, at a minimum, the projected dates for program initiation (usually Milestone B approval), other major decision points, and initial operating capability. The APB often includes other specific critical program events. The cost

section reflects the cost estimates of the total program as determined by the sponsor for all major elements of program life-cycle costs.⁴

Once the APB is approved by the MDA, the OSD staff monitors program execution through the Defense Acquisition Executive Summary (DAES) process. As part of this process, the program manager provides the most recent cost, performance, and schedule estimates—relative to APB goals and thresholds—on a quarterly basis. The program manager is required to notify the MDA of any breach of an APB threshold. In the event that a program breach occurs, a new APB must be approved by the MDA within 90 days. In some cases, the Congress must be notified of the program breach.

Programs employing an evolutionary acquisition strategy must design an APB structure to accommodate the strategy. DoDI 5000.2 requires the MDA to formally initiate each increment of an evolutionary acquisition program—initiation may occur at Milestone B or C. The program must establish program goals (cost, schedule, and performance) for each program increment. For programs using spiral development, the APB values would initially address the first increment of capability, and be updated as needed to reflect the goals for subsequent increments. For programs using incremental development, the APB might be a single document containing multiple sets of parameter values (each set defining an increment), or there may be separate APBs for each increment. For ACAT ID and ACAT IAM programs, the approval of the first increment would be subject to review by the DAB or ITAB, respectively. However, the approval of subsequent increments would likely be delegated to the CAE or other acquisition authority (unless the development or procurement dollar value of the increment qualified the increment as an MDAP in its own right).

Given the program cost, schedule, and performance goals, the program manager must develop an overarching program plan known as the Acquisition Strategy document that guides program execution to achieve the goals. DoDD 5000.1 empowers the program manager to serve as the single point of responsibility, authority, and accountability for accomplishing program objectives. However, preparation and execution of the acquisition strategy requires extensive collaboration between the program manager, user, and numerous functional communities engaged in or supporting DoD acquisition activities. Typically, the program manager organizes an IPT or similar cross-organizational entity to assist in the development and coordination of the Acquisition Strategy document. As the program matures, the acquisition strategy evolves through an iterative process and becomes increasingly more definitive in describing the structure and relationships of the major elements of the program. Due to the comprehensive nature of the Acquisition Strategy document, it has several principal considerations (see Figure 4). Further information on the Acquisition Strategy and each of its considerations may be found in the *Defense Acquisition Guidebook*, Chapter 2.

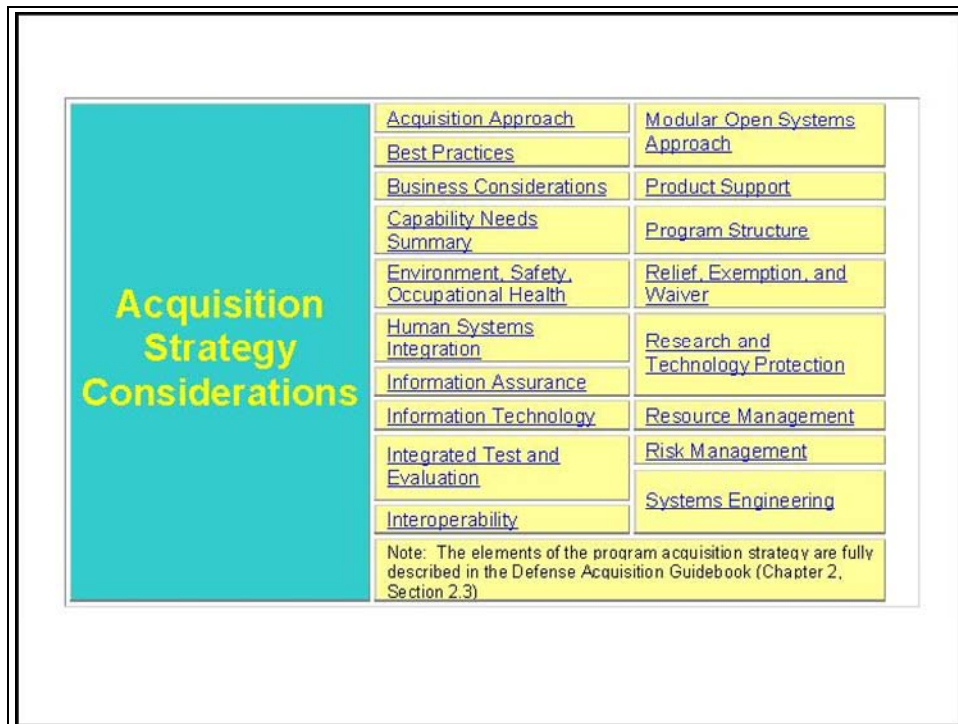

Figure F.4: Program Acquisition Strategy Considerations

Two topics in the Acquisition Strategy—Systems Engineering, and Test and Evaluation—are of sufficient importance that further discussion is provided here.

Acquisition and Systems Engineering

Systems engineering is the overarching process that a program team applies to transition from a stated capabilities need to an operationally effective and suitable system. Systems engineering applies several processes and disciplines across the acquisition life cycle and is intended to be the integrating mechanism for balanced solutions addressing capability needs, design considerations and constraints, as well as limitations imposed by technology, budget, schedule, and risk. Systems engineering typically is implemented through multi-disciplinary teams of various subject matter experts (often formally chartered as an IPT). While a program office usually has a Chief Engineer or Lead Systems Engineer in charge of implementing the systems engineering process, personnel from non-engineering organizations or from outside the program management organization may also perform activities related to the systems engineering effort.

A February 2004 USD(AT&L) policy memorandum establishes systems engineering policy for defense acquisition and mandates a formal Systems Engineering Plan for acquisition programs. An extract from the policy memorandum follows:

... I am establishing the following policy, effective immediately and to be included in the next revision of the DoD 5000 series acquisition documents:

Systems Engineering (SE). All programs responding to a capabilities or requirements document, regardless of acquisition category, shall apply a robust SE approach that balances total system performance and total ownership costs within the family-of-systems, systems-of-systems context. Programs shall develop a

Systems Engineering Plan (SEP) for Milestone Decision Authority (MDA) approval in conjunction with each Milestone review, and integrated with the Acquisition Strategy. This plan shall describe the program’s overall technical approach, including processes, resources, metrics, and applicable performance incentives. It shall also detail the timing, conduct, and success criteria of technical reviews.⁵

Figure 5 is a simplified portrayal of the systems engineering process and activities throughout the acquisition life cycle. There are two basic points to be made. First, systems engineering translates user-defined capabilities into actionable and documented engineering specifications. Each step of the systems engineering process builds upon the previous step to further define the technical solution. Second, a series of technical reviews are conducted at major transition points of the systems engineering effort. Technical reviews are used to confirm the outputs of the previous step and assess the readiness to proceed to the next step.

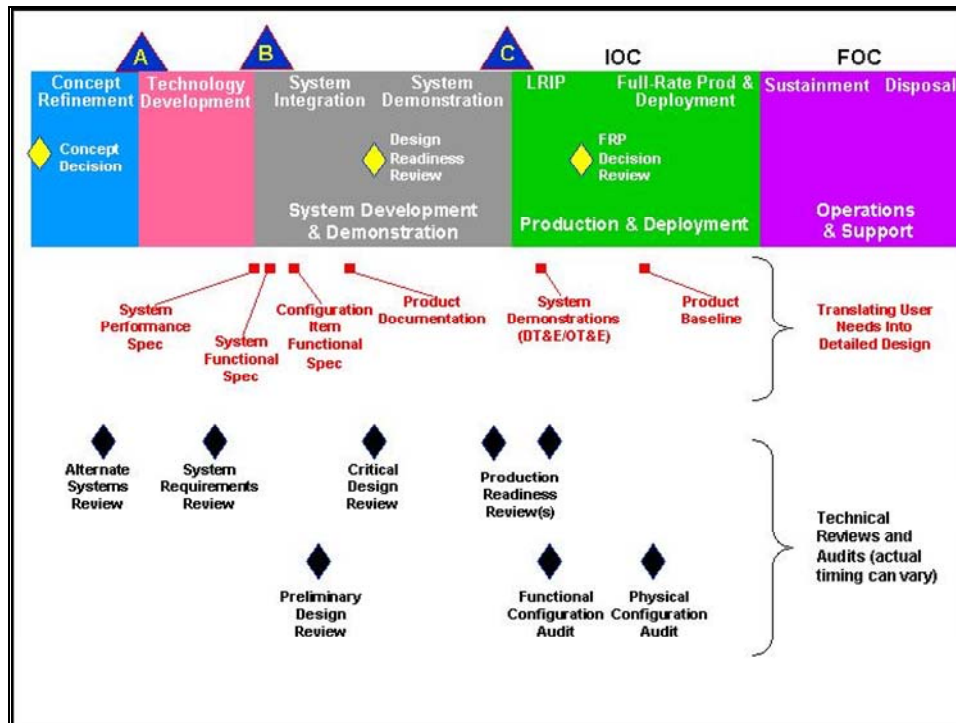

Figure F.5: Acquisition and Systems Engineering

Further information on systems engineering is found in the *Defense Acquisition Guidebook*, Chapter 4.

Test and Evaluation

Test and evaluation is an integral part of the defense acquisition process. Test and evaluation is structured to provide essential information to determine whether systems are operationally effective, suitable, survivable, and safe for intended use. Test and evaluation confirms attainment of technical performance parameters established in documented capability needs, often in the context of adversary capabilities as described in a system threat assessment.

DoDI 5000.2 provides considerable guidance for integrated test and evaluation (see Enclosure 5). In essence, the program manager—in concert with the user and test evaluation communities—coordinates developmental test and evaluation (DT&E), operational test and evaluation (OT&E), live-fire test and evaluation (LFT&E), and other testing activities into an efficient continuum, closely integrated with capability needs identification and system development and demonstration. The program manager develops test and evaluation objectives and strategy appropriate to each phase and milestone of the acquisition program. Figure 6 shows the timing of the critical test and evaluation planning documents and reports in support of the acquisition framework.

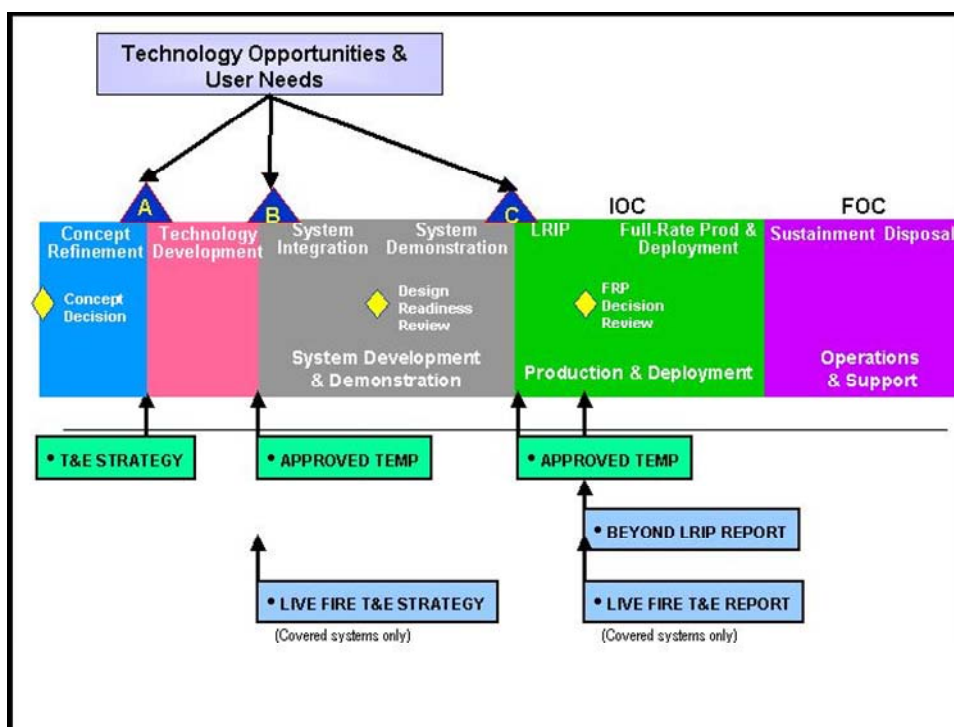

Figure F.6: Test and Evaluation Plans and Reports

The Test and Evaluation Strategy (TES), submitted at Milestone A, is an early planning document that describes the test and evaluation activities starting with the Technology Development phase. Much of the TES will describe how the critical technologies being developed will be demonstrated in an operationally relevant environment. The TES contains hardware and software maturity success criteria that will be used to assess critical technology maturity for entry into System Development and

Demonstration. In addition, the TES lays out in broad and general terms the preliminary test and evaluation strategy for Technology Development (possibly involving modeling and simulation), System Development and Demonstration, and beyond. The TES describes the materiel approach preferred concept, concepts of operations, and major performance capabilities from the ICD. Because the ICD statement of desired capabilities is broad, the TES also provides a broad, general discussion of the program's test and evaluation strategy.

The Test and Evaluation Master Plan (TEMP) is submitted at Milestone B and is updated at Milestone C and the Full-Rate Production Decision Review. The TEMP⁶ describes planned developmental, operational, and life fire testing, including measures to evaluate the performance of the system during these test periods; an integrated test schedule; and the resource requirements to accomplish the planned testing. The TEMP must be consistent with and complementary to the CDD (Milestone B) or the CPD (Milestone C).⁷ While there is no mandatory format for a TEMP, the *Defense Acquisition Guidebook*, Chapter 9, contains a suggested format. An important element of the suggested format is the capabilities crosswalk matrix. This matrix depicts the flow-down of desired capabilities, from the ICD to the CDD or CPD, then to the Measures of Effectiveness, Suitability, and Survivability, and finally the Critical Technical Parameters to ensure that all documented capabilities will be evaluated.

For programs with an evolutionary acquisition strategy, the test strategy (documented in the TES or later the TEMP) should address each increment intended for fielding as early as possible. The TEMP should be consistent with any time-phased statement of desired capabilities in the CDD or CPD.

The Director, Operational Test and Evaluation (DOT&E) analyzes the results of initial operational test and evaluation (IOT&E) conducted for each MDAP or other DOT&E-designated program. At the conclusion of IOT&E, the Director prepares a report known as the Beyond-LRIP (low-rate initial production) Report that documents whether the tests performed were adequate, and whether the test results confirm that the system is effective and suitable. The Director submits the Beyond-LRIP report to the Secretary of Defense, USD(AT&L), and the Congressional defense committees before the program may proceed beyond LRIP.

Certain weapon systems known as "covered systems" are subject to strict testing and reporting with respect to LFT&E. A system is considered covered when it is user-occupied and designed to provide some degree of protection to its occupants in combat. For such systems, the DOT&E reviews and approves the LFT&E strategy prior to Milestone B.⁸ DOT&E monitors and reviews the LFT&E of each covered system, and upon test completion prepares the LFT&E report that must be submitted to Congress before the system may proceed beyond LRIP.

Defense Acquisition and the Planning, Programming, Budgeting, and Execution Process

One key linkage among JCIDS, the Defense Acquisition System, and the PPBE process is the continual assessment of program affordability throughout the program life cycle. Even before a program is formally approved for initiation, affordability plays a key role in the identification of capability needs. Subsequently, program affordability continues to be part of the JCIDS process, which balances cost versus performance in

establishing key performance parameters. Moreover, all elements of program life-cycle cost are included in the resulting capability needs document (CDD or CPD). The program sponsor is expected to establish cost goals (in terms of thresholds and objectives) for major elements of program life-cycle cost for incorporation into the cost section of the Acquisition Program Baseline.

Once a program enters the acquisition system, the MDA considers full funding and affordability at each milestone decision point. Full funding ensures that sufficient resources (funding and manpower) are programmed and budgeted to execute the program acquisition strategy. In addition, the MDA also examines the realism of projected funding over the programming period and beyond, given likely resource constraints for the program sponsor. Both these points are a matter of policy contained in DoDD 5000.1. The key paragraph in the Directive is shown below:

Program Stability. The DoD Components shall develop realistic program schedules, long-range investment plans, and affordability assessments, and shall strive to ensure stable program funding. The MDA shall determine the appropriate point at which to fully fund an acquisition program, generally when a system concept and design have been selected, a PM has been assigned, capability needs have been approved, and system-level development is ready to begin. Full funding shall be based on the cost of the most likely system alternative.⁹

It has been a long-standing OSD practice to enforce full funding of acquisition programs, based on most likely cost, in the budget year and out-year program years. Experience has shown that full funding is a necessary condition for program stability. Full funding and program stability is especially important in joint and international acquisition programs.

Full funding is assessed by the Milestone Decision Authority at each decision point. As part of this assessment, the MDA reviews the actual funding (in the most recent President's Budget submission or Future Years Defense Program position) in comparison to the (time-phased) program office cost estimate. In addition, the MDA considers the funding recommendations made by the appropriate independent cost estimate team.¹⁰ If the MDA concludes that current funding does not adequately support the acquisition program, then the milestone acquisition decision memorandum will direct that the program sponsor make a funding adjustment and/or program restructure in the next FYDP update.

In addition to full funding, the MDA also assesses affordability at major decision points. In essence, affordability is defined as the degree to which the projected life-cycle cost of an acquisition program is in consonance with the long-range modernization, force structure, and manpower plans of the program sponsor, as well as for the Department as a whole. For MDAPs and MAIS programs, the program sponsor submits affordability assessments that are required at Milestones B and C (see DoDI 5000.2, Enclosure 3). The purpose of the assessment is for the program sponsor to demonstrate that the program's projected funding and manpower requirements are realistic and achievable, in the context of the sponsor's overall long-range modernization plan and likely fiscal and end-strength guidance. The *Defense Acquisition Guidebook* (see section 3.2.2) provides a recommended analytic approach for the sponsor's affordability assessment.

Science and Technology Program

The DoD Science and Technology (S&T) program supports the research, development, and demonstrations in sciences and technologies that are identified as important to future military capabilities and operations. The S&T program supports the future development of high technology weapons and information systems, as well as equipment to support and protect military personnel. The S&T program consists of basic research, applied research, and advanced technology development conducted by universities, industry, and several defense research laboratories in the military services. The Defense Advanced Research Projects Agency (DARPA) is the defense-wide central research and development organization for DoD. The Director of Defense Research and Engineering (DDR&E) in OSD oversees the DoD S&T program. On the behalf of the DDR&E, the Deputy Under Secretary of Defense for Science and Technology (DUSD(S&T)) has responsibility for leading the strategic planning process for DoD S&T.

There are three related documents that are used to guide the S&T planning process: the Basic Research Plan (BRP), the Defense Technology Area Plan (DTAP), and the Joint Warfighting Science and Technology Plan (JWSTP). These documents are collaborative products of OSD, Joint Staff, combatant commanders, military services, and defense agencies. The BRP presents the objectives and investment strategy for DoD-sponsored basic research. The DTAP presents the objectives and the investment strategies for applied research and advanced technology development. The JWSTP in effect examines the DTAP S&T activities from the warfighters' point of view. The JWSTP takes a joint perspective horizontally across the applied research and advanced technology development plans of the military departments and defense agencies to ensure that the requisite technology necessary to support the Joint Functional Concepts associated with future priority joint warfighting capabilities are supported.

The JWSTP also is used to sponsor Advanced Concept Technology Demonstrations (ACTDs) that can be used to accelerate the transition of prototype demonstrations of advanced technology opportunities into programs managed under the formal defense acquisition process. In support of this transition, a Military Utility Assessment (MUA), conducted at the end of the ACTD by the appropriate sponsoring combatant command, is used to support the decision to continue the effort as an acquisition program. In some cases, the MUA may be a suitable replacement for the required analysis used as the basis for the preparation of the ICD, and the MUA in such cases may be used to guide the development of a CDD for JROC approval.

End Notes

¹ This document follows the terminology and conventions used in the DoD 5000 series documents for defense acquisition. Space programs follow a different process and use a different terminology that is contained in the National Security Space Acquisition Policy 03-01, Guidance for DoD Space System Acquisition Process.

² Major Defense Acquisition Programs where the Milestone Decision Authority is delegated to the program's military service or defense agency are denoted as ACAT IC. Major Automated Information Systems where the MDA is delegated similarly are denoted as ACAT IAC. "ID" and "IAM" are not acronyms, only designations. The "ID" programs (weapon systems) are subject to DAB review, and the "IAM" programs (MAIS) are subject to ITAB review.

³ For DoD space programs, the MDA is the Under Secretary of the Air Force. For each space program approaching a milestone decision review, the space MDA convenes an Independent Program Assessment Team (IPAT) that assesses a program's readiness to proceed into the next acquisition phase. The IPAT's findings and recommendations are presented to the space MDA at a meeting of the Defense Space Acquisition Board (DSAB).

⁴ The program life-cycle cost estimate is reviewed by the MDA and is subject to revision based on independent estimates or assessments provided to the MDA. This point will be explained further later in this chapter.

⁵ Memorandum from Michael W. Wynne, "Policy for Systems Engineering in DoD," February 20, 2004.

⁶ For MDAPs and MAIS acquisition programs, the TEMP is jointly approved by the USD(AT&L) and the Director, Operational Test and Evaluation (DOT&E).

⁷ Because the Capability Development Document normally is not approved until around the time of Milestone B, the test and evaluation working-level integrated product team preparing the TEMP for the program manager typically will have to work from a draft version of the CDD. Similarly, the updated TEMP for Milestone C typically would be based on a draft CPD.

⁸ The USD(AT&L) or CAE may request a waiver from the Congressional defense committees in the case that full-up, system-level testing would be unreasonably expensive and impractical. In such cases, the waiver request offers an alternative plan of more limited LFT&E testing and analysis.

⁹ DoDD 5000.1, The Defense Acquisition System, May 12, 2003, Enclosure 1, p. 10.

¹⁰ For ACAT ID programs, an independent cost estimate is made by the OSD Cost Analysis Improvement Group (CAIG). For ACAT IC and MAIS acquisition programs, an independent cost estimate is made by a Component Cost Analysis (CCA) team.



This page intentionally blank.

Appendix G. Statutory Requirements of the Secretary and the Chairman

Documents and Reports Mandated by Congress

1. Annual President's Budget.

When due: On or after the first Monday in January but not later than the first Monday in February of each year.

Authority: 31USC1105

http://www.law.cornell.edu/uscode/html/uscode31/usc_sec_31_00001105----000-.html

2. Annual Reports Tied to President's Budget:

a. National Security Strategy Report

When due: On the date on which the President submits to Congress the budget for the next fiscal year.

Authority: 50USC404a

http://www.law.cornell.edu/uscode/html/uscode50/usc_sec_50_00000404---a000-.html

b. Annual Defense Authorization Request

When due: The Secretary of Defense shall transmit to Congress the annual defense authorization request for a fiscal year during the first 30 days after the date on which the President transmits to Congress the budget for that fiscal year.

Authority: 10USC113a

http://www.law.cornell.edu/uscode/html/uscode10/usc_sec_10_00000113---a000-.html

c. Annual Manpower Requirements Report

When due: Submitted each year not later than 45 days after the date on which the President submits to Congress the budget for the next fiscal year.

Authority: 10USC115a

http://www.law.cornell.edu/uscode/html/uscode10/usc_sec_10_00000115---a000-.html

d. Future Years Defense Program

When due: The Secretary of Defense shall submit to Congress each year, at or about the time that the President's budget is submitted to Congress, a future-years defense program (including associated annexes) reflecting the estimated expenditures and proposed appropriations included in that budget. Any such future-years defense program shall cover the fiscal year with respect to which the budget is submitted and at least the four succeeding fiscal years

Authority: 10USC221

http://www.law.cornell.edu/uscode/html/uscode10/usc_sec_10_00000221----000-.html

e. Annual Report on Aircraft Inventory

When due: The Under Secretary of Defense (Comptroller) shall submit to Congress each year a report on the aircraft in the inventory of the Department of Defense . . . when the President submits the budget to Congress.

Authority: 10USC484

http://www.law.cornell.edu/uscode/html/uscode10/usc_sec_10_00000484----000-.html

f. Comprehensive Net Assessment

When due: The Secretary of Defense shall transmit to Congress each year a report that contains a comprehensive net assessment of the defense capabilities and programs of the armed forces of the United States and its allies as compared with those of their potential adversaries. The Secretary shall transmit to Congress the report required for each year at the same time that the President submits the budget to Congress in that year. Such report shall be transmitted in both classified and unclassified form.

Authority: 10USC113(i)

http://www.law.cornell.edu/uscode/html/uscode10/usc_sec_10_00000113----000-.html

g. Annual Report on Combatant Command Requirements

When due: At or about the time that the budget is submitted to Congress for a fiscal year, the Chairman shall submit to the congressional defense committees a report on the requirements of the combatant commands.

Authority: 10USC153(c)

http://www.law.cornell.edu/uscode/html/uscode10/usc_sec_10_00000153----000-.html

h. Risks Under National Military Strategy

When due: Not later than January 1 of each odd-numbered year, the Chairman shall submit to the Secretary of Defense a report providing the Chairman's assessment of the nature and magnitude of the strategic and military risks associated with executing the missions called for under the current National Military Strategy. The Secretary shall forward the report, with the Secretary's comments thereon (if any), to Congress with the Secretary's next transmission to Congress of the annual Department of Defense budget justification materials in support of the Department of Defense component of the budget of the President submitted for the next fiscal year.

Authority: 10USC153(b)

http://www.law.cornell.edu/uscode/html/uscode10/usc_sec_10_00000153----000-.html

3. Other Annual Reports

a. Annual Report to the President and the Congress

When due: The Secretary shall report annually in writing to the President and the Congress on the expenditures, work, and accomplishments of the Department of Defense during the period covered by the report, together with (A) a report from each military department on the expenditures, work, and accomplishments of that

department; (B) itemized statements showing the savings of public funds, and the eliminations of unnecessary duplications . . . ; and (C) such recommendations as he considers appropriate. The Secretary of Defense shall include in this annual report a description of the operations tempo and personnel tempo of the armed forces.

Authority: 10USC113(c)(1) and 487

http://www.law.cornell.edu/uscode/html/uscode10/usc_sec_10_00000113----000-.html

http://www.law.cornell.edu/uscode/html/uscode10/usc_sec_10_00000487----000-.html

b. Annual Report of the Reserve Forces Policy Board

When due: At the same time that the Secretary submits the Annual Report to the President and the Congress, the Secretary shall transmit to the President and Congress a separate report from the Reserve Forces Policy Board on the reserve programs of the Department of Defense and on any other matters that the Reserve Forces Policy Board considers appropriate to include in the report.

Authority: 10USC113(c)(2)

http://www.law.cornell.edu/uscode/html/uscode10/usc_sec_10_00000113----000-.html

c. Annual Operations and Maintenance Report

When due: Not later than February 15 of each fiscal year.

Authority: 10USC116

http://www.law.cornell.edu/uscode/html/uscode10/usc_sec_10_00000116----000-.html

d. Joint Warfighting Experimentation

When due: The commander of the combatant command assigned by the Secretary of Defense to have the mission for joint warfighting experimentation shall submit to the Secretary an annual report on the conduct of joint experimentation activities for the fiscal year ending in the year of the report. Not later than December 1 of each year, the Secretary shall submit that report, together with any comments that the Secretary considers appropriate and any comments that the Chairman of the Joint Chiefs of Staff considers appropriate, to the Committee on Armed Services of the Senate and the Committee on Armed Services of the House of Representatives.

Authority: 10USC485

http://www.law.cornell.edu/uscode/html/uscode10/usc_sec_10_00000485----000-.html

e. Report on the Cost of Stationing US Forces Outside the United States

When due: Not later than April 8 of each year, the Secretary of Defense shall submit to the Committee on Armed Services and the Committee on Appropriations of the Senate and the Committee on Armed Services and the Committee on Appropriations of the House of Representatives a report on the cost of stationing United States forces outside of the United States.

Authority: 10USC113(j)

http://www.law.cornell.edu/uscode/html/uscode10/usc_sec_10_00000113----000-.html

4. Quadrennial Reports Tied to a Presidential Election

a. National Security Strategy Report

When due: Not later than 150 days after the date on which a new President takes office (i.e., five months from January 20 Inauguration Day, or June 20). This report is in addition to the one for that year transmitted by the previous President with the budget.

Authority: 50USC404a

http://www.law.cornell.edu/uscode/html/uscode50/usc_sec_50_00000404---a000-.html

b. Quadrennial Defense Review

When due: Review to be conducted during the year following a year evenly divisible by four (i.e., in the odd-numbered year immediately following a Presidential election – the same year in which a new Presidential term begins with inauguration in January). Report of the review to be submitted in the year following the year in which the review is conducted not later than the date on which the President submits the budget for the next fiscal year to Congress (i.e., report of QDR 2005 is due not later than 6 February 2006).

Authority: 10USC118

http://www.law.cornell.edu/uscode/html/uscode10/usc_sec_10_00000118---000-.html

c. Chairman’s Assessment of the QDR

When due: Submitted to the Secretary in time for inclusion in the QDR report.

Authority: 10USC118(e)

http://www.law.cornell.edu/uscode/html/uscode10/usc_sec_10_00000118---000-.html

d. Chairman’s Report on Roles and Missions

When due: Included as part of the Chairman’s assessment of the QDR, due to the Secretary in time for inclusion in the QDR report.

Authority: 10USC118(e)(2)

http://www.law.cornell.edu/uscode/html/uscode10/usc_sec_10_00000118---000-.html

5. Other Quadrennial Reports.

a. Quadrennial Quality of Life Review

When due: Submitted in the year following the year in which the review is conducted (which is not specified other than “every four years”), but not later than the date on which the President submits the budget for the next fiscal year.

Authority: 10USC118a

http://www.law.cornell.edu/uscode/html/uscode10/usc_sec_10_00000118---a000-.html

b. Quadrennial Report on Emerging Operational Concepts

When due: Not later than March 1 of each year evenly divisible by four, the Secretary of Defense shall submit to the Committee on Armed Services of the

Senate and the Committee on Armed Services of the House of Representatives a report on emerging operational concepts.

Authority: 10USC486

http://www.law.cornell.edu/uscode/html/uscode10/usc_sec_10_00000486----000-.html

6. Other Recurring Requirements.

a. Programming and Budget Guidance

Authority: 10USC113(g)(1)

http://www.law.cornell.edu/uscode/html/uscode10/usc_sec_10_00000113----000-.html

Remarks: The Secretary of Defense, with the advice and assistance of the Chairman of the Joint Chiefs of Staff, shall provide annually to the heads of Department of Defense components written policy guidance for the preparation and review of the program recommendations and budget proposals of their respective components. Such guidance shall include guidance on (A) national security objectives and policies; (B) the priorities of military missions; and (C) the resource levels projected to be available for the period of time for which such recommendations and proposals are to be effective.

b. Chairman's Program Recommendation

Authority: 10USC153(4)(A)

http://www.law.cornell.edu/uscode/html/uscode10/usc_sec_10_00000153----000-.html

Remarks: Subject to the authority, direction, and control of the President and the Secretary of Defense, the Chairman of the Joint Chiefs of Staff shall be responsible for advising the Secretary on the priorities of the requirements identified by the commanders of the unified and specified combatant commands.

c. Chairman's Program Assessment

Authority: 10USC153(4)(B) and (C)

http://www.law.cornell.edu/uscode/html/uscode10/usc_sec_10_00000153----000-.html

Remarks: Subject to the authority, direction, and control of the President and the Secretary of Defense, the Chairman of the Joint Chiefs of Staff shall be responsible for (a) advising the Secretary on the extent to which the program recommendations and budget proposals of the military departments and other components of the Department of Defense for a fiscal year conform with the priorities established in strategic plans and with the priorities established for the requirements of the unified and specified combatant commands; and (b) submitting to the Secretary alternative program recommendations and budget proposals, within projected resource levels and guidance provided by the Secretary, in order to achieve greater conformance with the priorities referred to in clause (a) above.

d. Contingency Planning Guidance

Authority: 10USC113g(2)

http://www.law.cornell.edu/uscode/html/uscode10/usc_sec_10_00000113----000-.html

Remarks: The Secretary of Defense, with the approval of the President and after consultation with the Chairman of the Joint Chiefs of Staff, shall provide to the

Chairman written policy guidance for the preparation and review of contingency plans. Such guidance shall be provided every two years or more frequently as needed and shall include guidance on the specific force levels and specific supporting resource levels projected to be available for the period of time for which such plans are to be effective.

e. Joint Strategic Capabilities Plan

Authority: 10USC153(a)(3)

http://www.law.cornell.edu/uscode/html/uscode10/usc_sec_10_00000153---000-.html

Remarks: Subject to the authority, direction, and control of the President and the Secretary of Defense, the Chairman of the Joint Chiefs of Staff shall be responsible for providing for the preparation and review of contingency plans which conform to policy guidance from the President and the Secretary of Defense.

f. Detection and Monitoring of Potential Aerial and Maritime Threats

Authority: 10USC113(k)

http://www.law.cornell.edu/uscode/html/uscode10/usc_sec_10_00000113---000-.html

Remarks: The Secretary of Defense, with the advice and assistance of the Chairman of the Joint Chiefs of Staff, shall provide annually to the Secretaries of the military departments and to the commanders of the combatant commands written guidelines to direct the effective detection and monitoring of all potential aerial and maritime threats to the national security of the United States. Those guidelines shall include guidance on the specific force levels and specific supporting resources to be made available for the period of time for which the guidelines are to be in effect.

g. Biennial Review of National Military Strategy

Authority: 10USC153(d)

http://www.law.cornell.edu/uscode/html/uscode10/usc_sec_10_00000153---000-.html

Remarks: Not later than February 15 of each even-numbered year, the Chairman shall submit to the Committee on Armed Services of the Senate and the Committee on Armed Services of the House of Representatives a report containing the results of a comprehensive examination of the national military strategy. Before submitting a report under this subsection to the Committees on Armed Services of the Senate and House of Representatives, the Chairman shall provide the report to the Secretary of Defense. The Secretary's assessment and comments thereon (if any) shall be included with the report.

h. Unified Command Plan

Authority: 10USC161

http://www.law.cornell.edu/uscode/html/uscode10/usc_sec_10_00000161---000-.html

Remarks: With the advice and assistance of the Chairman of the Joint Chiefs of Staff, the President, through the Secretary of Defense, shall establish combatant commands and specified combatant commands to perform military missions and prescribe their force structure. The Chairman periodically (and not less often than every two years) shall review the missions, responsibilities (including geographic

boundaries), and force structure of each combatant command; and recommend to the President, through the Secretary of Defense, any changes as may be necessary.

i. “Forces for Unified Commands” Document

Authority: 10USC162(a) and 161

http://www4.law.cornell.edu/uscode/uscode10/usc_sec_10_00000162----000-.html

http://www4.law.cornell.edu/uscode/uscode10/usc_sec_10_00000161----000-.html

Remarks: The Secretaries of the military departments shall assign all forces under their jurisdiction to unified and specified combatant commands or to the United States element of the North American Aerospace Defense Command to perform missions assigned to those commands. Such assignments shall be made as directed by the Secretary of Defense, including direction as to the command to which forces are to be assigned. The Secretary of Defense shall ensure that such assignments are consistent with the force structure prescribed by the President for each combatant command. [Section 161 requires the Chairman to periodically review the force structure of each combatant command and recommend to the Secretary of Defense any changes as may be necessary – this appears to be the basis for the “Forces for” document.

j. Quarterly Readiness Report

Authority: 10USC117(e)

http://www.law.cornell.edu/uscode/html/uscode10/usc_sec_10_00000117----000-.html

Remarks: The Secretary shall each quarter submit to the congressional defense committees a report in writing containing the results of the most recent joint readiness review.

This page intentionally blank.

Appendix H. Options Summary

This appendix lists all of the formal options identified in Chapters 3 and 4 of the report, together with their descriptions.

Option 3-A: Revitalize Joint Planning Document (JPD).

Description: Re-establish the JPD, which was a mechanism prescribed by the Joint Strategic Planning System (JSPS) for providing formal CJCS input to the DPG. Joint Staff Directorate for Strategic Plans and Policy (J-5) would lead this effort with J-8 programmatic and other analytical support.

Option 3-B: Align existing documents with SPG development timing.

Description: Use the NMS, the CRA and the ARCCR to support formal input to the SPG (in budget on years). Joint Staff J-5 would lead this effort with J-8 programmatic and other analytical support.

Option 3-C: Create decision support mechanism for building CPR.

Description: Joint Staff assembles Service and COCOM inputs on capabilities and programs and integrates them to create the CPR.

Option 3-D: Treat CPA principally as an audit mechanism.

Description: CPA focuses on its statutory role of advising the Secretary on compliance of POMs with strategic plans and requirements.

Option 3-E: Use CPA to advance new recommendations.

Description: In addition to its audit role, CPA provides another opportunity to provide input based on insights and changes that have emerged since the CPR.

Option 4-A: Conduct regular FAA and FNA across each Joint Functional Concept (JFC)

Description: Each FCB is currently responsible for developing and maintaining a Joint Functional Concept (JFC) that covers its assigned functional area. Under this option, each FCB would conduct a regular (e.g., annual) FAA and FNA on its assigned JFC to identify (1) all the tasks that need to be performed within the assigned capability areas, across the range of military operations; and (2) all the capabilities that exist or are programmed to exist, year-by-year through the end of the FYDP. The resulting inventory of tasks versus capabilities would reveal the capability gaps and excesses in the programmed force.

Option 4-B: Re-align OA to directly support SPG development.

Description: OA study Terms of Reference would be based on previous planning guidance and would require reports in time to influence new planning guidance.

Option 4-C: Implement the EPP as envisioned in the Aldridge Study.

Description: OSD (PA&E) would oversee and integrate level-1 joint mission analyses.

Option 4-D: Create new OSD/Joint Staff analytic management function.

Description: OSD and the Joint Staff would share responsibility for oversight and integration of level-1 joint mission analyses. This could (but need not) include the consolidation of JFC-wide FAA/FNAs and OA-series studies into a single process.

Option 4-E: Create new OSD “decision support cell.”

Description: New organization directly under the Secretary of Defense would oversee and integrate joint mission analyses.

Option 4-F: Expand joint analytic capacity.

Description: Increase allocation of resources to OSD and Joint Staff, and COCOM analytic staff and/or increase funding available for contracting outside studies.

Option 4-G: Reserve “functional” terminology for FCB functional areas.

Description: Reserve the terms FAA and FNA for level-1 analyses conducted by FCBs across their entire assigned functional areas and focus CBAs on level-2 capability needs analyses for priority issues identified in CJCS and Secretary of Defense planning guidance.

Option 4-H: Mandate use of OSD-approved / JROC-designated scenarios as baselines.

Description: CBAs conducted by the Services and Agencies, both as part of their internal processes and for JROC-directed CBAs, would be required to use specific, approved Blue Force CONOPS drawn from designated DPSs for analyses beyond the FYDP or, for analyses within the FYDP, the CONOPS in combatant command operation plans. CBAs would be free (indeed, encouraged) to explore alternatives to the common baseline.

Option 4-I: Encourage multiple sponsors to compete for solution analyses.

Description: Services and CSAs would conduct their own solution analyses and provide alternatives to a formal EoA.

Option 4-J: Employ JCD&E as integral part of solution analysis.

Description: Use human-in-the-loop simulation, field trials with surrogates, experimental articles, and prototypes to “test drive” technologies; co-evolve DOT_LPF with M; “tinker to see what works” as part of the Concept Refinement process, with feedback to the Concept Decision.

Option 4-K: Employ proposed EoA process for MPMI.

Description: Chairman would focus Joint Staff and FCB efforts on MPMI and use these to influence the new Concept Decision process.

Option 4-L: Establish formal level-1 trade-off assessment analysis.

Description: Recurring (annual or biennial) process for producing candidate programmatic trades and assessing risk of alternative programmatic options would be conducted in April-May to inform JPG and CPR development. Responsibility could be shared between OSD/PA&E and Joint Staff/J-8.

Option 4-M: Expand DPS set to cover the full range of military operations.

Description: Expand mid-term DPS set using current format and process to ensure complete ROMO coverage.

Option 4-N: Vary level of detail in DPSs according to priority or nature of analysis to be conducted.

Description: Create DPSs with different levels of detail, analogous to levels of plans described in the CPG, depending on priority or nature of the operational challenge depicted. This could include covering some mission types in the SSSP scenario only. (This option is currently under consideration by OSD (Policy).)

Option 4-O: Retain current process for DPS selection and prioritization.

Description: OSD (Policy) develops, for the Secretary’s approval, a list of scenarios to be developed, and the order in which they will be developed.

Option 4-P: Routinize the selection of DPS sets to align with key decision points.

Description: Routinize and regularize the timing and process for selection of DPS sets to align with key decision points in planning processes.

Option 4-Q: Fully implement published guidance to revise or replace DPSs on a two-year cycle.

Description: Implement guidance in DoDI 8260.2 to develop and/or update scenarios for strategic analysis at least every two years.

Option 4-R: Increase emphasis on analysis of near-term capabilities issues.

Description: Expand analytic resources and management attention given to analysis of current plans and current forces. Develop processes for capturing COCOM mission analyses that inform the CYAB.

Option 4-S: Enhance coordination between near-term war plans and mid-term scenario development.

Description: Clarify intent and decision rules for differences in priorities and content between war plans and mid-term scenario development (this is a current OSD (Policy) initiative).

Option 4-T: Broaden far-term scenarios to include consideration of alternative futures.

Description: Broaden far-term scenario development to include depictions of multiple alternative futures rather than detailed depictions of a single threat and operating environment.

Option 4-U: Separate mid-term from far-term in joint concepts.

Description: Use mid-term concepts (just beyond the FYDP) to conduct functional area and functional needs analyses based upon the approved programs in the current FYDP, also known as the “programmed force.” Create separate concepts or vision documents for the far term, emphasizing new missions or tasks that might emerge and emphasizing as well the technological possibilities that could be exploited in the future to change the way we do things now or enable us to do things in the future we cannot do “now” (i.e., with the programmed force).

Option 4-V: Distribute JCD&E resources and attention among level-1 far-term exploration of alternative strategic and operational concepts, prioritized level-2 “problems to be solved,” and level-3 concept refinement.

Description: Over the past several years, the emphasis in the JCD&E plan has swung from far-term, high-level concepts – like Rapid Decisive Operations – to near-term focus on countering improvised explosive devices (IEDs). Efforts should be made to focus the efforts on MPMI and balance expenditures among the three levels of JCD&E.

Pros: Makes JCD&E more relevant to DoD capabilities development decisions; involves COCOMs more fully in JCD&E by addressing their issues that result in MPMIs.

Cons: Will require greater Pentagon and COCOM oversight of JCD&E plan priorities.

Option 4-W: Use DPSs in the place of JOCs in capability-based analysis.

Description: A specified set of DPSs would provide the context for a revised level-1 FCB FAA/FNA process.

Pros: Eliminates JOCs that have consumed many man-years but have not produced much value; uses in their place National Military Strategies for WOT, Combating WMD, Cyberspace, etc.; covers greater range of operations.

Cons: The community that has formed around JOCs will resist change.

Option 4-X: Develop routine practice of experimentation in joint training and COCOM exercises.

Description: Routinely evaluate new DOTMLPF solution concepts in joint training and COCOM exercises.

Pros: Allows iterative evaluation of DOTMLPF concepts, and facilitates rapidly bridging priority capability gaps through user-developer concurrent development; promotes adaptation of forces to new circumstances. Allows rapid feedback to JIC authors, replaces consensus solutions to “staffing issues” with empirical evidence from field trials.

Cons: Need to balance experimentation with training requirements.

Option 4-Y: Strengthen links between JCD&E and S&T planning.

Description: Revise concept templates in 3010.01B to require explicit consideration of future technologies; realign S&T plans from “technology areas” to JCAs; make JWSTP panel chairs full members of associated FCBs.

Pros: Helps identify technologies with the greatest promise; shapes S&T investment to hasten maturation of technologies with greatest utility; switch to JCAs puts S&T focus on capabilities vice platforms, facilitates common lexicon and data sets, fits better with portfolio approach.

Cons: Requires more extensive collaboration; further stretches already thin S&T manpower (two officials in DDR&E currently chair three JFC panels each).

This page intentionally blank.

Appendix I. Acronym Glossary

ACAT - Acquisition Category	CY - Calendar Year
ACTD - Advanced Concept Technology Demonstration	CYAB - Current Year Analytic Baseline
ADM - Acquisition Decision Memorandum	DAB - Defense Acquisition Board
AMA - Analysis of Materiel and non-materiel Approaches	DAES - Defense Acquisition Executive Summary
AoA - Analysis of Alternatives	DAPA - Defense Acquisition Performance Assessment
APB - Acquisition Program Baselines	DAWG - Deputy's Advisory Working Group
ARCCR - Annual Report on Combatant Commander Requirements	DAWMS - Deep Attack Weapons Mix Study
ASD - Assistant Secretary of Defense	DCR - DOTMLPF Change Recommendation
AT&L - Acquisition, Technology and Logistics	DDR&E - Director, Defense Research & Engineering
BES - Budget Estimate Submission	DIA - Defense Intelligence Agency
BRP - Basic Research Plan	DoD - Department of Defense
BSP - Baseline Security Posture	DoDD - Department of Defense Directive
BY - Budget Year	DoDI - Department of Defense Instruction
CAE - Component Acquisition Executive	DOTMLPF - Doctrine, Organization, Training, Materiel, Leadership and Education, Personnel and Facilities
CAIG - Cost Analysis Improvement Group	DPG - Defense Planning Guidance
CBA - Capabilities-Based Assessment	DPP - Defense Program Projection
CBP - Capabilities-Based Planning	DPS - Defense Planning Scenario
CCA - Component Cost Analysis	DSB - Defense Science Board
CCJO - Capstone Concept for Joint Operations	DSLRC - Defense Senior Leadership Conference
CD - Concept Decision	DTAP - Defense Technology Area Plan
CDD - Capability Development Document	EoA - Evaluation of Alternatives
CDM - Concept Decision Memorandum	EPP - Enhanced Planning Process
CINC - Commander in Chief	EXCOM - Executive Committee
CJCS - Chairman of the Joint Chiefs of Staff	FAA - Functional Area Analysis
CJCSI - Chairman of the Joint Chiefs of Staff Instruction	FCB - Functional Capabilities Board
CJCSM - Chairman of the Joint Chiefs of Staff Manual	FFRDC - Federally-Funded Research and Development Center
COCOM - Combatant Command	FNA - Functional Needs Analysis
CONOPS - Concept of Operations	FOC - Full Operational Capability
CONPLAN - Concept Plan	FRP - Full-Rate Production
CORM - Commission on Roles and Missions	FSA - Functional Solutions Analysis
CPA - Chairman's Program Assessment	FYAB - Future Year Analytic Baseline
CPD - Capability Production Document	FYDP - Future Years Defense Program
CPG - Contingency Planning Guidance	GFM(G) - Global Force Management (Guidance)
CPR - Chairman's Program Recommendation	HD&CS - Homeland Defense & Civil Support
CRA - Chairman's Risk Assessment	IAMD - Integrated Air and Missile Defense
CSA - Combat Support Agency	

ICCARM - Integrated Cross-Capability Assessment and Risk Management

ICD - Initial Capabilities Document

IDA - Institute for Defense Analyses

IOC - Initial Operating Capability

IOT&E - Initial Operational Test & Evaluation

IPDM - Intelligence Program Decision Memorandum

IPL - Integrated Priority List

IPT - Integrated Product Team

ITAB - Information Technology Acquisition Board

JCA - Joint Capability Area

JCB - Joint Capability Board

JCD - Joint Capability Document

JCD&E - Joint Concept Development & Experimentation

JCDRP - Joint Concept Development and Revision Plan

JCIDS - Joint Capabilities Integration and Development System

JCS - Joint Chiefs of Staff

JCTD - Joint Capability Technology Demonstration

JFC - Joint Functional Concept

JFEO - Joint Forcible Entry Operations

JIC - Joint Integrating Concept

JMETL - Joint Mission Essential Task List

JNA - Joint Net Assessment

JOC - Joint Operating Concept

JOpsC - Joint Operations Concept

JPD - Joint Planning Document

JPEO - Joint Program Executive Office

JPG - Joint Programming Guidance

JQRR - Joint Quarterly Readiness Report

JRAC - Joint Rapid Acquisition Cell

JROC - Joint Requirements Oversight Council

JS - Joint Staff

JSCP - Joint Strategic Capabilities Plan

JSPS - Joint Strategic Planning System

JSR - Joint Strategy Review

JTF - Joint Task Force

JTMP - Joint Training Master Plan

JUON - Joint Urgent Operational Need

JUSS - Joint Undersea Superiority Study

JWCA - Joint Warfighting Capabilities Assessment

JWSTP - Joint Warfighting Science and Technology Plan

KPP - Key Performance Parameter

LFT&E - Live Fire Test & Evaluation

LL - Lessons Learned

LPTR - Linking Plans To Resources

LRIP - Low-Rate Initial Production

LSI - Lead System Integrator

MAIS - Major Automated Information System

MCS - Mobility Capabilities Study

MDA - Milestone Decision Authority

MDAP - Major Defense Acquisition Program

MID - Management Initiative Decision

MNS - Mission Needs Statement

MOA - Memorandum Of Agreement

MOE - Measures of Effectiveness

MOP - Measures of Performance

MORS - Military Operations Research Society

MPMI - Most Pressing Military Issues

MSFD - Multi-Service Force Deployment

MUA - Military Utility Assessment

NDS - National Defense Strategy

NII - Networks and Information Integration

NMS - National Military Strategy

NMSD - National Military Strategy Document

NSS - National Security Strategy

OA - Operational Availability

OFT - Office of Force Transformation

OIPT - Overarching Integrated Product Team

OPLAN - Operation Plan

ORD - Operational Requirement Document

OSD - Office of the Secretary of Defense

P&D - Production & Deployment

PA&E - Program Analysis & Evaluation

PBD - Program Budget Decision

PDM - Program Decision Memorandum

PE - Program Element

PEO - Program Executive Office

PIA - Post Independent Analysis
PM - Program Manager
POM - Program Objective Memorandum
PPBE - Planning, Programming, Budgeting and Execution
PPBS - Planning, Programming, and Budgeting System
PSYOP - Psychological Operations
QDR - Quadrennial Defense Review
RD&E - Research, Development, Test & Evaluation
ROMO - Range Of Military Operations
S&T - Science and Technology
SCG - Security Cooperation Guidance
SDD - System Development and Demonstration
SE&IO - Systems Engineering & Integrated Organization
SecDef - Secretary of Defense
SGS - Strategic Guidance Statement
SI - System Integrator
SoS - System of Systems
SPG - Strategic Planning Guidance
SSSP - Steady State Security Posture
T&E - Test & Evaluation
TD&CR - Technology Development & Concept Refinement
TEMP - Test and Evaluation Master Plan
TES - Test and Evaluation Strategy
TOA - Total Obligational Authority
TPG - Transformation Planning Guidance
TTL - Tag, Track, Locate
UCP - Unified Command Plan
UJTL - Universal Joint Task List
USD - Under Secretary of Defense
USJFCOM - United States Joint Forces Command
USPACOM - United States Pacific Command
USSOCOM - United States Special Operations Command
VCJCS - Vice Chairman of the Joint Chiefs of Staff
WIPT - Working-level Integrated Product Team
WMD - Weapons of Mass Destruction
WOT - War on Terrorism

This page is intentionally blank.

REPORT DOCUMENTATION PAGE

*Form Approved
OMB No. 0704-0188*

Public reporting burden for this collection of information is estimated to average 1 hour per response, including the time for reviewing instructions, searching existing data sources, gathering and maintaining the data needed, and completing and reviewing this collection of information. Send comments regarding this burden estimate or any other aspect of this collection of information, including suggestions for reducing this burden to Department of Defense, Washington Headquarters Services, Directorate for Information Operations and Reports (0704-0188), 1215 Jefferson Davis Highway, Suite 1204, Arlington, VA 22202-4302. Respondents should be aware that notwithstanding any other provision of law, no person shall be subject to any penalty for failing to comply with a collection of information if it does not display a currently valid OMB control number. **PLEASE DO NOT RETURN YOUR FORM TO THE ABOVE ADDRESS.**

1. REPORT DATE (DD-MM-YY) 15-09-06	2. REPORT TYPE Study (Final)	3. DATES COVERED (From - To) February – September 2006
4. TITLE AND SUBTITLE Improving Integration of Department of Defense Processes for Capabilities Development Planning		5a. CONTRACT NO. DASWO1-04-C-0003 and W74V8H-05-C-0042
		5b. GRANT NO.
		5c. PROGRAM ELEMENT NO(S).
6. AUTHOR(S) Dr. John T. Hanley, Jr., Task Leader Mr. Michael F. Fitzsimmons Mr. James H. Kurtz Mr. Lance M. Roark Mr. Vincent P. Roske, Jr. Mr. Daniel L. Cuda		5d. PROJECT NO.
		5e. TASK NO. CA-8-2621
		5f. WORK UNIT NUMBER
7. PERFORMING ORGANIZATION NAME(S) AND ADDRESS(ES) Institute for Defense Analyses 4850 Mark Center Drive, Alexandria, VA 22311-1882		8. PERFORMING ORGANIZATION REPORT NO. IDA Paper P-4154
9. SPONSORING / MONITORING AGENCY NAME(S) AND ADDRESS(ES) Directorate for Force Structure, Resources and Assessment, J-8 The Joint Staff 8000 Joint Staff Pentagon, Room 1E965 Washington, DC 20318-8000		10. SPONSOR'S / MONITOR'S ACRONYM(S)
		11. SPONSOR'S / MONITOR'S REPORT NO(S).
12. DISTRIBUTION / AVAILABILITY STATEMENT Approved for public release; distribution unlimited.		
13. SUPPLEMENTARY NOTES Unclassified		
14. ABSTRACT DoD has taken many steps toward implementing the vision of rational, agile, joint planning that has been advanced under the banner of “capabilities-based planning.” However, the processes supporting these efforts are not fully integrated with one another and are not fully aligned with the congressional budget cycle that drives resourcing decisions. This paper presents a detailed analysis of the Department’s planning processes and decision support mechanisms, with particular focus on the processes that aim to define, design, and develop capabilities for the future joint force. The study focused on the integration, within the overarching framework of the Planning, Programming, Budgeting and Execution (PPBE) system, of five “capabilities development planning” sub-elements: (1) the development of strategic and planning guidance; (2) the Analytic Agenda; (3) the Joint Capabilities Integration and Development System (JCIDS); (4) joint concept development and experimentation; and (5) the acquisition system. The paper presents a variety of options for improving the performance and integration of these processes and offers considerations for the implementation of the options. Appendices provide extensive background information on the planning processes addressed.		
15. SUBJECT TERMS Aldridge Study, capabilities, capability needs, capabilities-based assessment (CBA), capabilities-based planning (CBP), Capstone Concept for Joint Operations (CCJO), Chairman of the Joint Chiefs of Staff (CJCS), combatant command (COCOM), concept decision (CD), concept of operations (CONOPS), Chairman’s Program Assessment (CPA), Chairman’s Program Recommendation (CPR), Chairman’s Risk Assessment (CRA), DAWG [Deputy’s Advisory Working Group], DOTMLPF [doctrine, organization, training, materiel, leader development and education, personnel, facilities], Defense Planning Scenario (DPS), EoA [Evaluation of Alternatives], EPP [enhanced planning process], functional area analysis (FAA), Functional Capabilities Board (FCB), functional needs analysis (FNA), FYDP [future years defense program], global force management (GFM), Integrated Cross-Capability Assessment and Risk Management (ICCARM), inte-		

grated priority list (IPL), Joint Capability Area (JCA), Joint Capability Board (JCB), joint concept development and experimentation (JCD&E), Joint Capabilities Integration and Development System (JCIDS), joint functional concept (JFC), joint integrating concept (JIC), joint mission essential task list (JMETL), joint operating concept (JOC), JOpsC [Joint Operations Concepts], Joint Planning Document (JPD), Joint Programming Guidance (JPG), Joint Requirements Oversight Council (JROC), Joint Strategic Planning System (JSPS), Joint Training Master Plan (JTMP), joint urgent operational need (JUON), Joint Warfighting Science and Technology Plan (JWSTP), Linking Plans to Resources (LPTR), milestone decision authority (MDA), mission analysis, most pressing military issues (MPMI), multi-Service force deployment (MSFD), Operational Availability (OA), operation plan (OPLAN), Program Analysis and Evaluation (PA&E), program budget decision (PBD), program decision memorandum (PDM), program objective memorandum (POM), PPBE [planning, programming, budgeting and execution], Quadrennial Defense Review (QDR), range of military operations (ROMO), S&T [science and technology], Strategic Planning Guidance (SPG), uniform joint task list (UJTL).

16. SECURITY CLASSIFICATION OF:			17. LIMITATION OF ABSTRACT UU	18. NO. OF PAGES 196	19a. NAME OF RESPONSIBLE PERSON MG Michael A. Vane, USA Vice Director for Force Structure, Resources and Assessment, J-8
a. REPORT U	b. ABSTRACT U	c. THIS PAGE U			19b. TELEPHONE NUMBER (Include Area Code) (703) 697-8155/8163